

# Hydraulics

S  
C  
h  
y  
d  
r  
a  
u  
n  
i  
c  
s

## Char-Lynn® Disc Valve Hydraulic Motors

11-01-878  
EN-0201



2000, 4000, 6000, and 10,000 Series  
Hydraulic Motors

We Manufacture

Solutions

# Catalog of Disc Valve Hydraulic Motors from One of the World's Leading Manufacturers of Off Highway Mobile Components — Eaton Hydraulics

In the late 1950's the original low speed, high torque hydraulic motor was developed from a pump gerotor element consisting of an internal gear ring and a mating gear or star. While attaching the internal gear ring to the housing as a non moving part, oil was ported to pressurize and turn the internal star in an orbit around a center point. This slow turning star coupled with a splined drive to the output shaft became the Char-Lynn® Orbit® motor. A few years after this original Char-Lynn Orbit motor was introduced another original motor concept went into production. This motor had rolls incorporated into the internal gear ring, this element was identified by the name Geroler® and is a registered trade name of Eaton Hydraulics. From these early years the Geroler motor has seen many design changes

to make these Geroler motors the best the industry has to offer. Examine the simplicity of these Geroler disc valve motors shown below. Also examine all the following pages for high value Char-Lynn disc valve motors from Eaton Hydraulics.

## Geroler® Displacement Mechanism

Motors with the Geroler element provide high starting and running torque. The Geroler element minimizes friction and thereby increases efficiency while providing smooth output shaft rotation even at very low speeds. Motor shaft rotation can be instantly reversed by changing direction of input/output flow while generating equal torque in either

direction. The displacements available provide a wide variety of speeds and torques from any Series motor.

## Disc Valve

The function of the disc valve is to distribute fluid to the Geroler pockets. The pressure balanced sealing surface on the valve face maintains minimal leakage. Char-Lynn disc valve motors can be used in the same system with a radial piston pump and also in closed loop systems. The patented wear compensated disc valve provides top performance.

## Heavy Duty Bearings

Roller bearings permit high radial loads. The radial load capacity is matched to the torque capability of the motor. The high radial load capacity can eliminate the need for outboard bearings or other mechanical components thereby reducing installation cost and allowing the motors to be used on heavier vehicles in traction drive applications.

## 2000 Series Motor

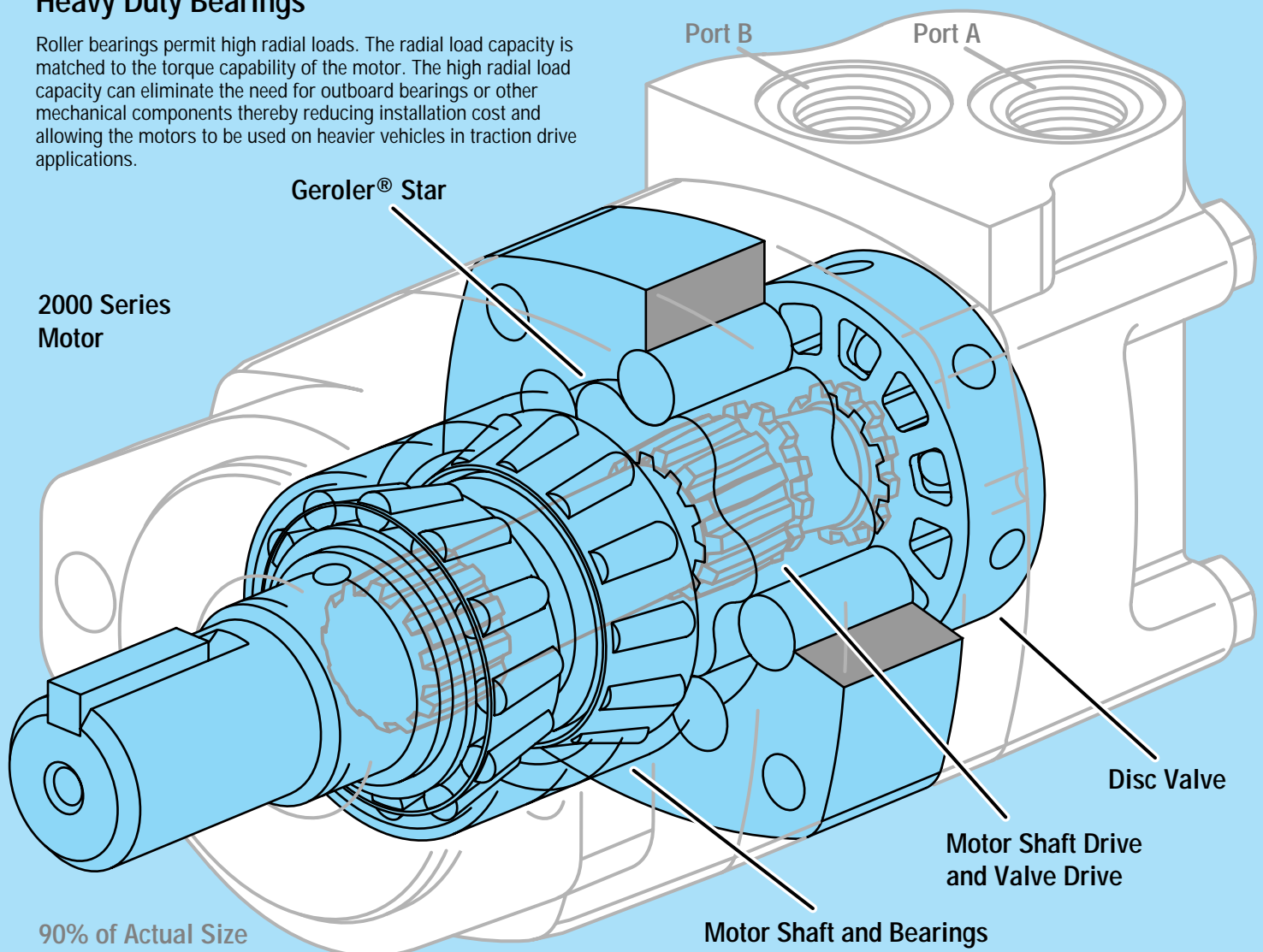

## Design Features

Char-Lynn Hydraulic motors provide design flexibility. All disc valve motors are available with various configurations consisting of:

- Displacement (Geroler size)
- Output Shaft
- No Shaft and Bearing Assembly (Bearingless Motor)
- Port Configuration
- Mounting Flange
- Other Special Features

### Standard Motor

The standard motor mounting flange is located as close to the output shaft as possible. This type of mounting supports the motor close to the shaft load. This mounting flange is also compatible with many standard gear boxes.

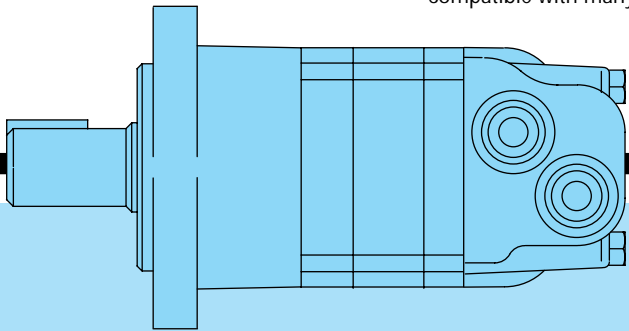

### Wheel Motor

The wheel motor mounting flange is located near the center of the motor which permits part or all of the motor to be located inside the wheel or roller hub. In traction drive applications, loads can be positioned over the motor bearings for best bearing life. This wheel motor mounting flange provides design flexibility in many applications.

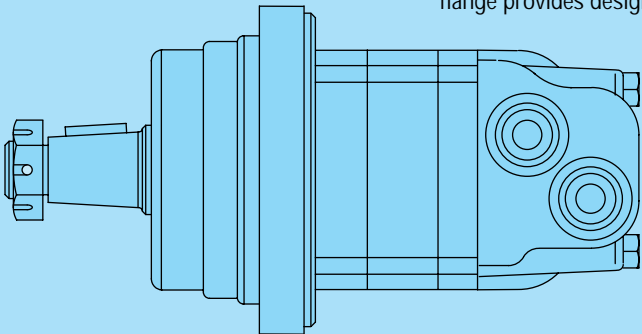

### Bearingless Motor

This bearingless motor has the same drive components as the standard and wheel motors (with the exception that the motor is assembled without the output shaft, bearings and bearing housing). The bearingless motor is especially suited for applications such as gear boxes, winch drives, reel and roll drives. Bearingless motor applications must be designed with a bearing supported internal spline to mate with the bearingless motor drive. Product designs using these hydraulic motors provide considerable cost savings.

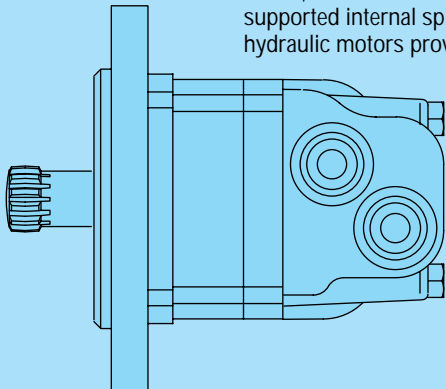

# 2000 Series

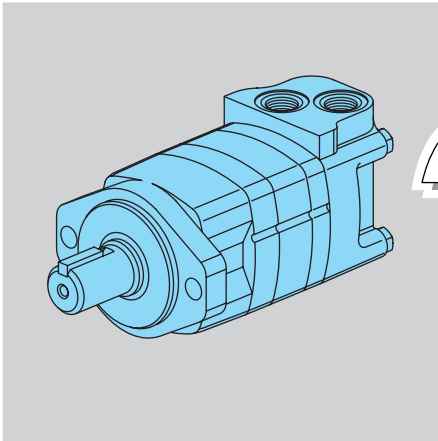

# 2000

## 2000 Series

Geroler® Element .....	9 Displacements
Flow LPM [GPM] .....	75 [20] Continuous**
	115 [30] Intermittent*
Speed .....	Up to 924 RPM
Pressure Bar [PSI] ...	200 [3000] Cont.
	300 [4500] Inter.
Torque Nm [lb-in] ....	845 [7470] Cont.
	930 [8225] Inter.

2000 Series Displacement Size = cubic centimeter per shaft revolution ( cm<sup>3</sup>/r )  
= cubic inch per shaft revolution ( [ in<sup>3</sup>/r ] )

- 80 [ 4.9]
- 100 [ 6.2]
- 130 [ 8.0]
- 160 [ 9.6]
- 195 [11.9]
- 245 [14.9]
- 305 [18.7]
- 395 [24.0]
- 490 [29.8]

### Mounting Flange

- 4 Bolt (Bearingless) 101,6 [4.00] Pilot Dia. and 13,59 [.535] Dia. Mounting Holes on 127,0 [5.00] Dia. B.C.
- 2 Bolt (SAE A) (Standard) 82,5 [3.25] Pilot Dia. and 13,59 [.535] Mounting Holes on 106,4 [4.19] Dia. B.C.
- 4 Bolt (Wheel) 107,9 [4.25] Pilot Dia. and 13,59 [.535] Dia. Mounting Holes on 147,6 [5.81] Dia. B.C.
- 4 Bolt (Standard) 82,5 [3.25] Pilot Dia. and 13,59 [.535] Dia. Mounting Holes on 106,4 [4.19] Dia. B.C.
- 4 Bolt Magneto 82,5 [3.25] Pilot Dia. and 13,59 [.535] Dia. Mounting Holes on 106,4 [4.19] Dia. B.C.
- 2 Bolt (SAE B) 101,6 [4.00] Pilot Dia. and 14,27 [.562] Dia. Mounting Holes on 146,0 [5.75] Dia. B.C.

### Output Shaft

- Bearingless
- 1 inch Dia. Straight with Woodruff Key, 1/4-20 Threaded Hole and 38,4 [1.51] Max. Coupling Length
- 1-1/4 inch Dia. Straight with Straight Key, 3/8-16 Threaded Hole and 47,3 [1.86] Max. Coupling Length
- 32 mm Dia. Straight with Straight Key, M8 x 1,25 -6H Threaded Hole and 56,4 [2.22] Max. Coupling Length
- 1-1/4 inch Dia. Splined 14 T, 3/8-16 Threaded Hole and 33,0 [1.30] Min. Full Spline Length and 45,5 [1.79] Max. Coupling Length
- 1-1/4 inch Dia. Tapered with Straight Key and Nut
- SAE 6B Splined 6 T, 1/4-20 Threaded Hole and 22,8 [.90] Min. Full Spline Length and 28,8 [1.13] Max. Coupling Length
- 7/8 inch Dia. Splined 13 T, 15,2 [.60] Min. Full Spline Length and 30,8 [1.21] Max. Coupling Length
- 25 mm Dia. Straight with Straight Key, M8 x 1,25 -6H Threaded Hole and 38,1 [1.50] Max. Coupling Length

### Port Type

- 7/8-14 O-ring (Staggered) with 7/16-20 O-ring Case Drain
- G 1/2 (BSP) (Staggered) with G 1/4 (BSP) Case Drain
- Manifold Mount with 3/8-16 UNC Mounting Threads (3) and 7/16-20 O-ring Case Drain
- Manifold Mount with M10 x 1,5 -6H Mounting Threads (3) and G 1/4 (BSP) Case Drain
- 1-1/16—12 O-ring (Positioned 180° Apart) with 7/16-20 O-ring Case Drain
- 7/8-14 O-ring (End Ports) with 7/16-20 O-ring Case Drain (Rear)

### Special Features

- Viton® Shaft Seal
- Viton Seals
- Free Running Geroler
- Speed Sensor
- Two Speed Option
- Hot Oil Shuttle
- Corrosion Protected
- Seal Guard Package

\*\* Continuous— (Cont.) Continuous rating, motor may be run continuously at these ratings.

\* Intermittent— (Inter.) Intermittent operation, 10% of every minute.

Viton® is a Registered Trade Name of Dupont Corp.

# 4000 Compact Series

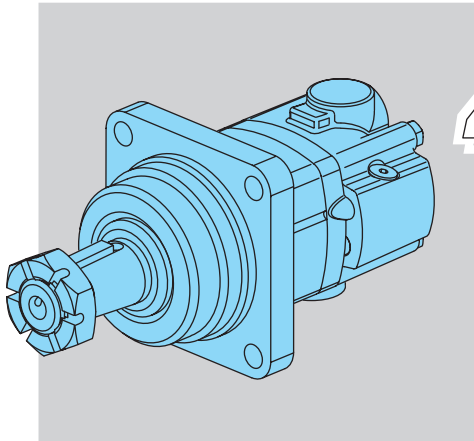
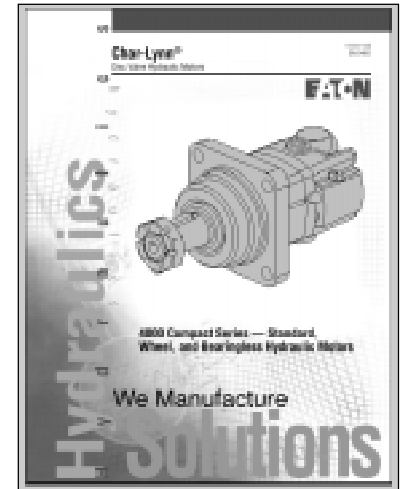

# 4000

## Compact Series

See Catalog 11-01-113 for a Char-Lynn 4000 Compact Series hydraulic motor, this motor has the same package size as the 2000 Series with 4000 Series performance.

### 4000 Compact Series

Geroler® Element.....	6 Displacements
Flow LPM [GPM] .....	75 [20] Continuous**
	115 [30] Intermittent*
Speed .....	Up to 707 RPM
Pressure Bar [PSI] ...	200 [3000] Cont.
	300 [4500] Inter.
Torque Nm [lb-in] ....	932 [ 8250] Cont.
	1166 [10320] Inter.

4000 Compact Series Displacement Size = cubic centimeter per shaft revolution (cm<sup>3</sup>/r)  
= cubic inch per shaft revolution ([ in<sup>3</sup>/r ])

- 160 [ 9.8]
- 200 [12.3]
- 250 [15.4]
- 325 [19.8]
- 395 [24.0]
- 490 [29.8]

#### Mounting Flange

- 4 Bolt (Bearingless) 101,6 [4.00] Pilot Dia. and 13,59 [.535] Dia. Mounting Holes on 127,0 [5.00] Dia. B.C.
- 2 Bolt (SAE A) (Standard) 82,5 [3.25] Pilot Dia. and 13,59 [.535] Mounting Holes on 106,4 [4.19] Dia. B.C.
- 4 Bolt (Wheel) 107,9 [4.25] Pilot Dia. and 13,59 [.535] Dia. Mounting Holes on 147,6 [5.81] Dia. B.C.
- 4 Bolt (Standard) 82,5 [3.25] Pilot Dia. and 13,59 [.535] Dia. Mounting Holes on 106,4 [4.19] Dia. B.C.
- 4 Bolt Magneto 82,5 [3.25] Pilot Dia. and 13,59 [.535] Dia. Mounting Holes on 106,4 [4.19] Dia. B.C.
- 2 Bolt (SAE B) 101,6 [4.00] Pilot Dia. and 14,27 [.562] Dia. Mounting Holes on 146,0 [5.75] Dia. B.C.

#### Output Shaft

- Bearingless
- 1-1/4 inch Dia. Straight with Straight Key, 3/8-16 Threaded Hole and 47,3 [1.86] Max. Coupling Length
- 1-1/2 inch Dia. Straight with Straight Key, 3/8-16 Threaded Hole and 67,8 [2.67] Max. Coupling Length
- 32 mm Dia. Straight with Straight Key, M 8 x 1,25 -6H Threaded Hole and 56,4 [2.22] Max. Coupling Length
- 40 mm Dia. Straight with Straight Key, M12 x 1,75 -6H Threaded Hole and 79,6 [3.13] Max. Coupling Length
- 1-1/4 inch Dia. Splined 14 T, 3/8-16 Threaded Hole and 38,1 [1.50] Min. Full Spline Length and 53,1 [2.09] Max. Coupling Length
- 1-1/2 inch Dia. Splined 17 T, 31,2 [1.23] Min. Full Spline Length and 51,8 [2.04] Max. Coupling Length
- 1-1/4 inch Dia. Tapered with Straight Key and Nut
- 1-5/8 inch Dia. Tapered with Straight Key and Nut

#### Port Type

- 7/8-14 O-ring (Staggered) with 7/16-20 O-ring Case Drain
- G 1/2 (BSP) (Staggered) with G 1/4 (BSP) Case Drain
- Manifold Mount with 3/8-16 UNC Mounting Threads (3)
- Manifold Mount with M10 x 1,5 -6H Mounting Threads (3)
- 1-1/16-12 O-ring (Positioned 180° Apart)
- 7/8-14 O-ring (End Ports) with 7/16-20 O-ring Case Drain (Rear)

#### Case Flow

- 7/16-20 UNF 2-B O-ring Port
- G 1/4 (BSP) Straight Thread Port
- Hot Oil Shuttle with 7/16-20 UNF 2-B O-ring Port
- Hot Oil Shuttle with G 1/4 (BSP) Straight Thread Port

#### Back-Pressure Relief Valve

- Set at 4,5 bar [65 PSI]

#### Special Features

- Viton® Seal
- Speed Sensor
- Corrosion Protected
- Seal Guard Package

Viton® is a Registered Trade Name of Dupont Corp.

\*\* Continuous— (Cont.) Continuous rating, motor may be run continuously at these ratings.

\* Intermittent— (Inter.) Intermittent operation, 10% of every minute.

# 4000 Series

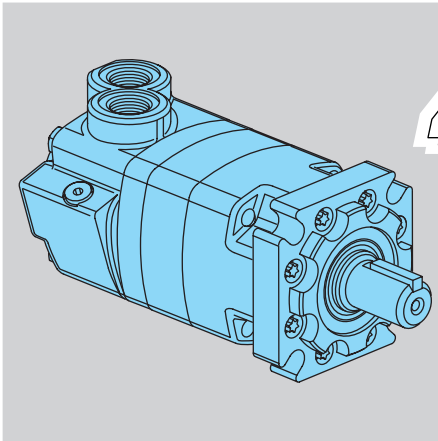

# 4000

## 4000 Series

Geroler® Element .....	10 Displacements
Flow LPM [GPM] .....	95 [25] Continuous**
	150 [40] Intermittent*
Speed .....	Up to 868 RPM
Pressure Bar [PSI] ...	200 [ 3000] Cont.
	300 [ 4500] Inter.
Torque Nm [lb-in] .....	970 [ 8600] Cont.
	1180 [10450] Inter.

4000 Series Displacement Size = cubic centimeter per shaft revolution ( cm<sup>3</sup>/r )  
= cubic inch per shaft revolution ( [ in<sup>3</sup>/r ] )

- 110 [ 6.7]
- 130 [ 7.9]
- 160 [ 9.9]
- 205 [12.5]
- 245 [15.0]
- 280 [17.1]\*\*\*
- 310 [19.0]
- 395 [24.0]
- 495 [30.0]
- 625 [38.0]

### Mounting Flange

- 4 Bolt (Bearingless) 127,0 [5.00] Pilot Dia. and 14,27 [.562] Dia. Mounting Holes 161,9 [6.38] Dia. B.C.
- 4 Bolt (SAE B) (Standard) 101,6 [4.00] Pilot Dia. and 14,7 [.58] Mounting Slots on 127,0 [5.00] Dia. B.C.
- 4 Bolt (Wheel) 139,7 [5.50] Pilot Dia. and 14,3 [.56] Dia. Mounting Holes on 165,1 [6.50] Dia. B.C.
- 4 Bolt (SAE C) (Standard) 127,0 [5.00] Pilot Dia. and 14,3 [.56] Dia. Mounting Holes on 161,9 [6.38] Dia. B.C.

### Output Shaft

- Bearingless
- 1-1/4 inch Dia. Straight with Straight Key, 3/8-16 Threaded Hole and 53,1 [2.09] Max. Coupling Length
- 1-5/8 inch Dia. Tapered with Straight Key and 1-1/4—18 UNEF Slotted Hex. Nut
- 1-1/4 inch Dia. Splined 14 T with 38,1 [1.50] Min. Full Spline Length and 53,1 [2.09] Max. Coupling Length
- 1-1/2 inch Dia. Splined 17 T with 31,2 [1.23] Min. Full Spline Length
- 40 mm Dia. Straight with Straight Key, M12 x 1,75-6H Threaded Hole

### Port Type

- 1-1/16—12 O-ring with 7/16-20 O-ring Case Drain and Check Valve
- G 3/4 (BSP) O-ring with G 1/4 (BSP) O-ring Case Drain and Check Valve
- 3/4 inch 4 Bolt Split Flange with 7/16-20 O-ring Case Drain and Check Valve
- 7/8-14 O-ring with 9/16-18 O-ring Case Drain with Shuttle Valve

### Special Features

- Viton Shaft Seal
- Viton Seals
- Hot Oil Shuttle
- Corrosion Protected

\*\*\* For performance and dimension data contact your Eaton Hydraulics representative.

\*\* Continuous— (Cont.) Continuous rating, motor may be run continuously at these ratings.

\* Intermittent— (Inter.) Intermittent operation, 10% of every minute.

# 6000 Series

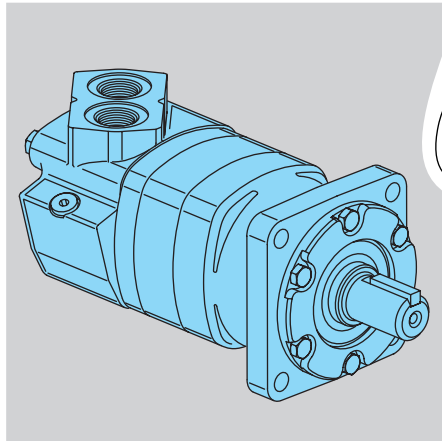

# 6000

## 6000 Series

Geroler® Element .....	9 Displacements
Flow LPM [GPM] .....	150 [40] Continuous**
	225 [60] Intermittent*
Speed .....	Up to 866 RPM
Pressure Bar [PSI] ...	200 [ 3000] Cont.
	300 [ 4500] Inter.
Torque Nm [lb-in]....	1685 [14920] Cont.
	1875 [16580] Inter.

**6000 Series Displacement Size = cubic centimeter per shaft revolution ( cm<sup>3</sup>/r )**  
 = cubic inch per shaft revolution ( [ in<sup>3</sup>/r ] )

- 195 [11.9]
- 245 [15.0]
- 310 [19.0]
- 390 [23.9]
- 490 [30.0]
- 625 [38.0]
- 740 [45.0]\*\*
- 805 [49.0]\*\*
- 985 [60.0]

### Mounting Flange

- 4 Bolt (Bearingless) 127,0 [5.00] Pilot Dia. and 14,3 [.56] Dia. Mounting Holes on 161,9 [6.38] Dia. B.C.
- 4 Bolt (SAE CC)(Standard) 127,0 [5.00] Pilot Dia. and 14,3 [.56] Mounting Holes on 161,9 [6.38] Dia. B.C.
- 4 Bolt (Wheel) 139,7 [5.50] Pilot Dia. and 14,3 [.56] Dia. Mounting Holes on 184,1 [7.25] Dia. B.C.

### Output Shaft

- Bearingless
- 1-1/2 inch Dia. Straight with Straight Key, 3/8-16 Threaded Hole and 56,7[2.23] Max. Coupling Length
- 1-3/4 inch Dia. Tapered with Straight Key and 1-1/4—18 UNEF Slotted Hex. Nut
- 1-1/2 inch Dia. Splined 17 T with 40,3 [1.59] Min. Full Spline Length and 3/8-16 Threaded Hole
- 40 mm Dia. Straight with Straight Key, M12 x 1,75-6H Threaded Hole

### Port Type

- 1-5/16-12 O-ring with 7/16-20 O-ring Case Drain and Shuttle Valve
- G 1 (BSP) O-ring with G 1/4 (BSP) O-ring Case Drain and Check Valve
- 3/4 inch 4 Bolt Split Flange with 7/16-20 O-ring Case Drain and Check Valve

### Special Features

- Viton Shaft Seal
- Viton Seals
- Hot Oil Shuttle
- Corrosion Protected

\*\*\* For performance and dimension data contact your Eaton Hydraulics representative.

\*\* Continuous— (Cont.) Continuous rating, motor may be run continuously at these ratings.

\* Intermittent— (Inter.) Intermittent operation, 10% of every minute.

# 10,000 Series

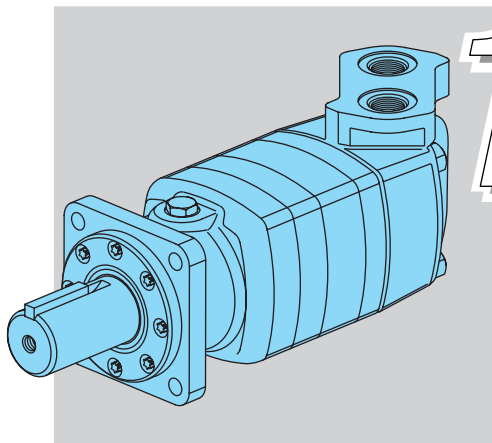

# 10,000

## 10,000 Series

Geroler® Element .....	4 Displacements
Flow LPM [GPM] .....	170 [45] Continuous**
	265 [70] Intermittent*
Speed .....	Up to 784 RPM
Pressure Bar [PSI] ...	200 [3000] Cont.
	270 [4000] Inter.
Torque Nm [lb-in] ...	2700 [23910] Cont.
	3440 [30460] Inter.

10,000 Series Displacement Size = cubic centimeter per shaft revolution (cm<sup>3</sup>/r)  
= cubic inch per shaft revolution ( [ in<sup>3</sup>/r ] )

- 345 [21.0]
- 480 [29.2]
- 665 [40.6]
- 940 [57.4]

### Mounting Flange

- 4 Bolt (Bearingless) 152,4 [6.00] Pilot Dia. and 20,88 [.522] Dia. Mounting Holes 228,6 [9.00] Dia. B.C.
- 4 Bolt (Standard) 127,0 [5.00] Pilot Dia. and 17,02 [.670] Mounting Holes on 161,9 [6.37] Dia. B.C.
- 4 Bolt (Wheel) 177,8 [7.00] Pilot Dia. and 17,02 [.670] Dia. Mounting Holes on 209,5 [8.25] Dia. B.C.

### Output Shaft

- Bearingless
- 2-1/4 inch Dia. Straight with Straight Key, 1/2-20 Threaded Hole and 97,5[3.84] Max. Coupling Length
- 2-1/4 inch Dia. Tapered with Straight Key and 1-1/2—18 UNEF Slotted Hex. Nut
- 2-1/8 inch Dia. Splined 16 T with 52,1 [2.05] Min. Full Spline Length and 1/2-20 UNEF Threaded Hole

### Port Type

- 1-5/16-12 O-ring with 9/16-18 O-ring Case Drain
- 1-1/4 Split Flange with 9/16-18 O-ring Case Drain

### Special Features

- Viton Shaft Seal
- Viton Seals
- Two Speed Option
- Corrosion Protected

\*\* Continuous— (Cont.) Continuous rating, motor may be run continuously at these ratings.

\* Intermittent— (Inter.) Intermittent operation, 10% of every minute.



## Design Flexibility

Char-Lynn motors are truly built for high torque low speed. A lot of power is derived from this small package. This power advantage provides the designer with a product that can be used for overall compactness in addition to taking full advantage of the high pressure ratings typical of present day hydraulic components.

Char-Lynn Disc Valve hydraulic motors allow the designer to put the power where it is needed. Indeed, these motors are small in size, big in output power. Hence, the small package can eliminate a lot of installation problems. Furthermore, the motors can be mounted directly on the driven device away from the original power source which eliminates other mechanical linkages such as chains, sprockets, belts, pulleys, gears, rotating drive shafts, and universal joints. Several motors can be driven from the same power source and can be connected in series or parallel to each other.

## Durability

The design and method of manufacture of three critical drive train components, valve drive, shaft drive, and output shaft, give these motors durability. Consequently, these durable disc valve motors stand up against high hydraulic pressures. Other built in features, such as the rugged **Tapered** roller bearings provide a good match to this tough design.

## Performance Rating

Our method of rating these motors recognizes that at slower speeds and flow, higher pressures and torque are permitted. Hence, our performance data shows the complete flow range (down to 1 liter per minute or 1/4 gallon per minute) and speed range (down to one revolution per minute depending on application).

## Controllable Speeds

Char-Lynn motors operate at low speeds that remain very near constant even when load varies. Shaft speed is varied smoothly, easily and economically using simple inexpensive controls. Also, these motors are reversible. Consequently, direction of shaft rotation can be changed instantly with equal output torque in either direction.

## Dependable Performance

Highly precise manufacturing of parts and the disc valve's unique wear compensating design provide consistent, dependable performance and long life even under varying conditions.

## Reliability

Char-Lynn motors are self contained, with hydraulic fluid providing lubrication. These motors are completely sealed so they can operate safely and reliably in hostile environments such as dust, dirt, steam, water, and heat and provide reliable performance.

## High Efficiencies

Char-Lynn disc valve motors have high efficiencies providing high output for the pressure and flow supplied. The high mechanical efficiency enables you to obtain a given torque with a smaller displacement motor.

Volumetric efficiency is high and speed is relatively constant with little variation due to changes in load. Speed is controlled easily and smoothly.

In conclusion, these efficiencies mean less heat buildup in the hydraulic system.

## Case Drain and Shuttle Valve Options

Many hydraulic systems can benefit from the use of a system case drain. Char-Lynn disc valve motors provide this feature built in. One of the advantages for case drain flow is that contamination is flushed from the system. This flushing also aids in cooling the system and lowering the case pressure which will extend motor seal life. With a case drain line in place, oil pressure in the gear box (Bearingless motor applications) can also be controlled. In applications where more system cooling and flushing is required, a shuttle valve option is available in 2000, 4000, and 6000 Series motors.

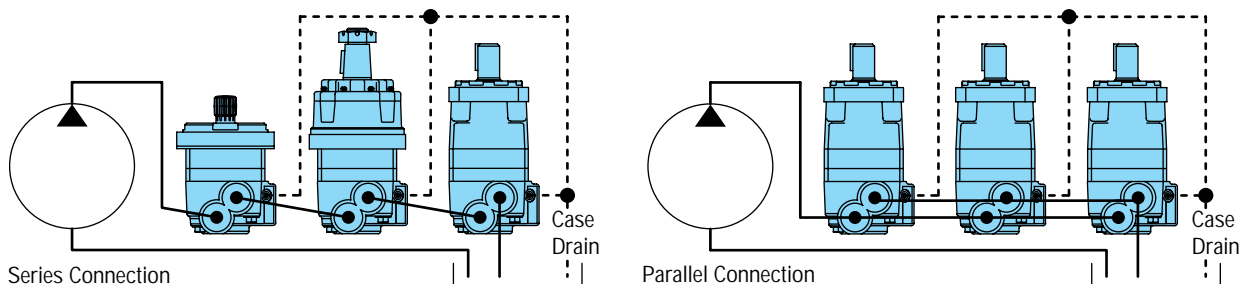

# Typical (Closed Loop) Hydraulic Circuit Shuttle Flow 2000, 4000, 6000 Series

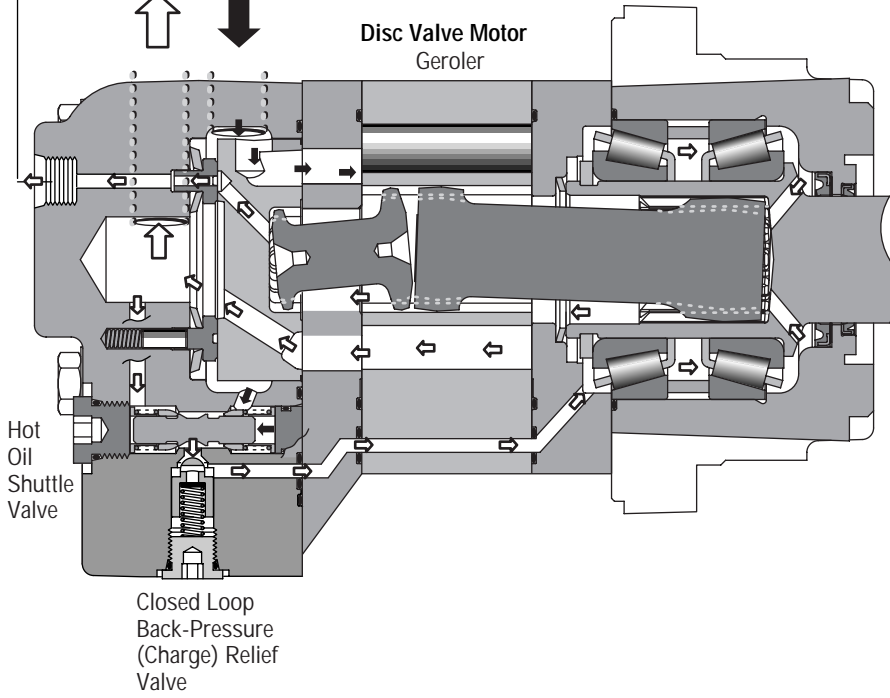
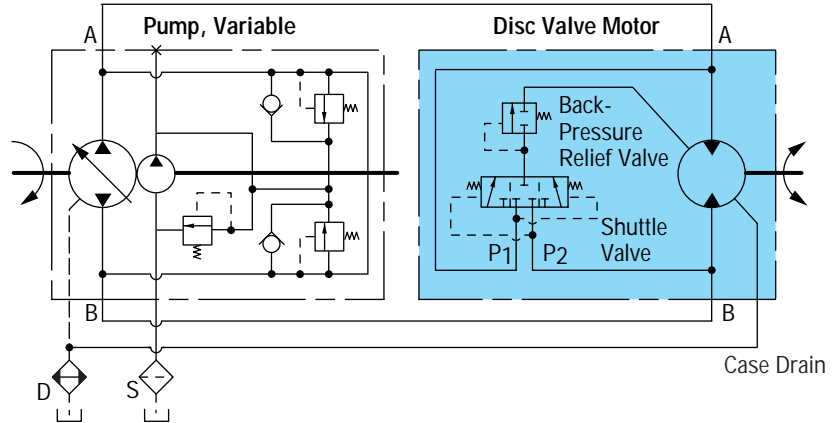
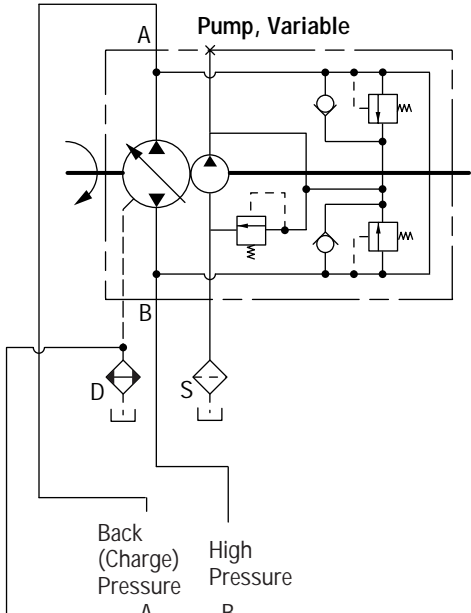
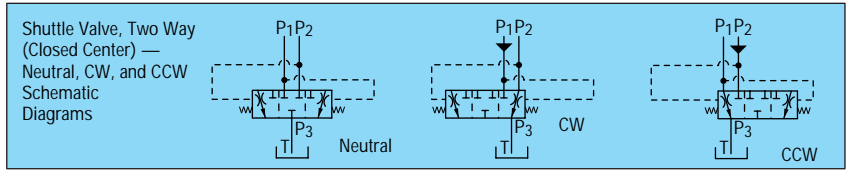

**Typical Disc Valve Motor Shuttle Flow with 4,5 bar [65 PSI] Back-Pressure Relief Valve (Typical Data)**  
Due to Machining Tolerances, Flow May be More or Less

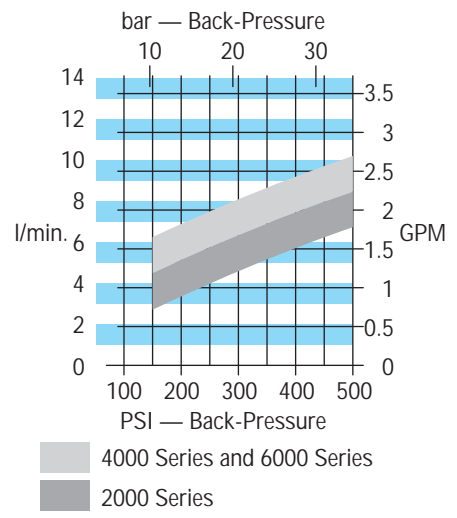

Disc Valve Motor with shuttle valve **must have a case drain to tank**, without this drain line the internal drive splines will not have adequate lubrication.

Low Speed High Torque Hydraulic Motors with Shuttle and Charge Pressure Relief Valve — Patent No. U.S. 4,645,438.

## Speed Sensor 2000, 4000 and 6000 Series

Eaton has developed a speed sensor specifically designed for LSHT motors. The design is rugged and fully protected against accidental reverse polarity or short circuit hook up. A built in pull up resistor simplifies installation with control systems.

This sensor is fully compatible with mobile vehicle electrical systems and gives a reliable digital on/off signal over a wide speed range and temperature range. The sensor is field-serviceable; no factory setting or shimming is required.

**Supply Voltage:** 8 to 24 Vdc (compatible with 12V vehicle systems)

**Supply Current:** 20 mA max. (Vs) (including internal pull-up resistor)

**Output Voltage:** Low < .5 Vdc @ 10 mA; output is open collector with 10kΩ pull-up resistor.

**Connection** — standard 3 prong Weatherpack connector with 18 AWG (american wire gage) cables:

- Position A (red) = power supply
- Position B (white) = signal output
- Position C (black) = common

### 2000 Series

**Output Speed Sensor** — digital on/off signal from a Hall Effect switch; 30 pulses/revolution

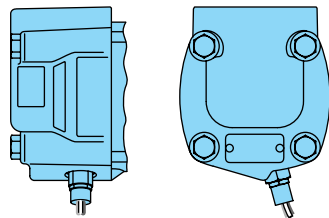

**Output Quadrature Speed Sensor** — 60 pulses/revolution

### 4000 Series

**Output Speed Sensor** — digital on/off signal from a Hall Effect switch; 36 pulses/revolution

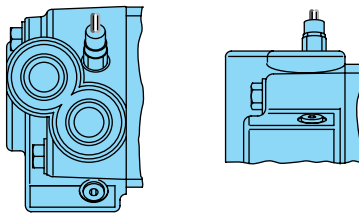

**Output Quadrature Speed Sensor** — 72 pulses/revolution

### 6000 Series

**Output Speed Sensor** — digital on/off signal from a Hall Effect switch; 40 pulses/revolution

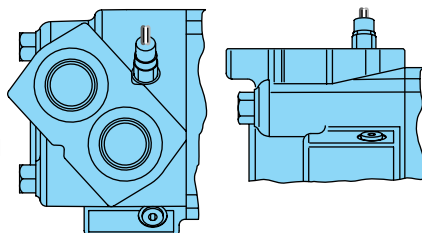

**Output Quadrature Speed Sensor** — 80 pulses/revolution

## Quadrature Speed Sensor 2000, 4000 and 6000 Series

Eaton has developed a new **speed** and **direction** sensor, based on the field proven technology of our standard sensor, designed for off road environments. The new sensor is based on the principle of quadrature and has two output versions.

- The first version has two output signals 90° out of phase. Each output provides one pulse per target tooth.
- The second version has a speed signal that is twice the output pulses per revolution and it also has a direction signal. For example, the 2000 Series versions provide 60 symmetrical pulses per revolution with the 30-tooth target.

**Outputs** — Digital signals from NPN transistors (open collector output with internal 10K pull-up resistors).

**Supply Voltage:** 8 to 24 Vdc\* (compatible with 12V vehicle conditions)

**Supply Current:** 40 mA max. (Including internal pull-up resistors)

**Output**

**Low Voltage:** 0.5 Vdc maximum @ 10 mA

The sensor has reverse polarity protection, short circuit protection, load dump protection and EMC (Electromagnetic Compatibility) protection (the customer should qualify the EMC protection in their specific application).

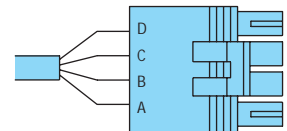

Weatherpack Tower Connector

**Connections** —

Standard 4 prong Weatherpack connector with 18 AWG (American Wire Gage) cables or M12 threaded connector:

#### Weatherpack (Version 1)

- Position A (red) = power supply
- Position B (black) = common
- Position C (orange) = output one
- Position D (yellow) = output two

#### M12 Connector (Version 1)

- Pin 1 = power supply
- Pin 2 = output one
- Pin 3 = common
- Pin 4 = output two

#### Weatherpack (Version 2)

- Position A (red) = power supply
- Position B (black) = common
- Position C (blue) = speed signal
- Position D (white) = direction

#### M12 Connector (Version 2)

- Pin 1 = power supply
- Pin 2 = direction
- Pin 3 = common
- Pin 4 = speed signal

**Note:** The speed sensor or quadrature speed sensor option does **NOT** include read-out display. Possible sources for read-out display include:

Eaton Corporation  
**Durant Products**  
 901 South 12th Street  
 Watertown, WI 57094  
 1-800-289-3866

## Shaft Seal

This time proven shaft seal design has a patented feature which allows the seal lip to follow shaft deflection under high side loads and therefore provides better sealing. Additionally, these seals can withstand case pressure up to: 140 Bar [2000 PSI] 2000 Series, 100 Bar [1500 PSI] 4000 Series, 70 Bar [1000 PSI] 6000 Series, and 20 Bar [300 PSI] 10,000 Series.

To optimize seal life, reduce case pressures (with case drain) at shaft speeds greater than 250 RPM.

## Optional Seal Guard Package for 2000, 4000, and 6000 Series

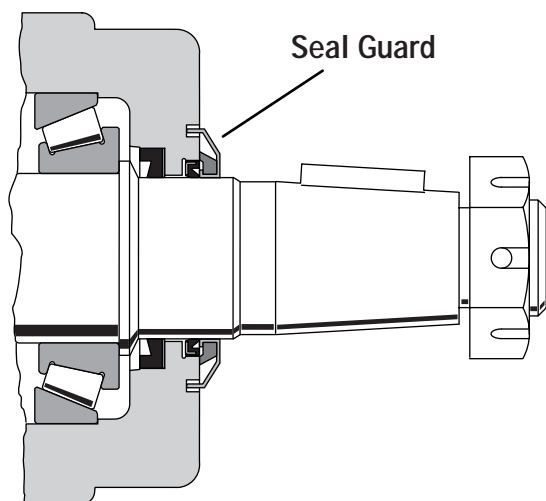

In response to the need for robust seal protection requirements, Eaton now offers a seal guard package. This feature consists of a metal shield that protects an internal wiper seal. The shield is interference-fit on the output shaft and rotates with the output shaft. For added protection, the shield is recessed into a special groove in the bearing housing face.

Centrifugal force causes foreign debris to be forced away from the high pressure shaft and dust seal area. The seal guard does not seal hydraulic fluid. Instead, it protects the standard seals from damage caused by foreign debris. Typical applications benefiting from this feature include street sweepers, industrial sweepers, and harvesting machinery.

**NOTE:** This option is used in conjunction with the special front retainer with shield groove. Special feature (Hardware) option code "28" for 2000, "13" for 4000, and "14" for 6000 Series, **these motors include the seal guard package, special front retainer and a special shaft with additional length** (6000 Series with design code -006 (effective December 1, 1995) will not require a special front retainer and standard shafts will accept the seal guard).

## Internal Check Valves

An internal check valve is provided to relieve case pressure to the low pressure side of the motor. This check valve system is adequate for most applications. In addition, motors have an external case pressure drain port for use when continuous back pressure exceeds: 140 Bar [2000 PSI] 2000 Series, 100 Bar [1500 PSI] 4000 Series, 70 Bar [1000 PSI] 6000 Series, and 20 Bar [300 PSI] 10,000 Series.

## Corrosion Protected Disc Valve Motors

2000, 4000, 6000, and 10,000 Series motors are available with a corrosion resistant coating for use in hostile environments. This coating protects the motor from salt water, and various chemicals and is especially effective in marine, food processing, cleansing, fishing, and agricultural applications. Motor output shaft plating helps eliminate seal damage caused by these caustic or acid materials. Char-Lynn disc valve motors are available with just the output shaft plated, or with plated shaft and entire motor exterior coating.

# Contents

## General Information

Description, Features and Options .....	Page 2- 3
Product Overview 2000 Series Motors .....	4
Product Overview 4000 Compact Series Motors .....	5
Product Overview 4000 Series Motors .....	6
Product Overview 6000 Series Motors .....	7
Product Overview 10 000 Series Motors .....	8
General Hydraulic Motor Information .....	9
Shuttle Flow Hydraulic Circuit Explanation .....	10
Speed Sensor and Quadrature Speed Sensor .....	11
Shaft Seal and Seal Guard Option .....	12
Internal Check Valves .....	12
Corrosion Protection .....	12
Contents .....	13

## Product Information — 2000 Series Motors

Specifications .....	14
Performance Data .....	15-19
Dimensions — Standard and Wheel Mount .....	20-21
Dimensions — Bearingless .....	22
Installation Information — Bearingless Motor .....	23
Dimensions — Mounting Flanges .....	24
Dimensions — Shafts .....	25
Shaft Side Load — Standard and Wheel .....	26
Dimensions — Ports .....	27-28
Product Numbers .....	29
Model Code .....	30
Two Speed Motor .....	31
Two Speed Motor Circuit .....	32
Two Speed Motor Specifications .....	33
Two Speed Motor Dimensions .....	34
Two Speed Motor Product Numbers .....	35
Hayes Brake System .....	36

## Product Information — 4000 series Motors

Specifications .....	37
Performance Data .....	38-41
Dimensions — Standard and Wheel Mount .....	42-43
Dimensions — Bearingless .....	44
Installation Information — Bearingless Motor .....	45
Dimensions — Shafts .....	46
Shaft Side Load — Standard and Wheel .....	47
Dimensions — Ports .....	48
Product Numbers .....	49
Model Code .....	50

## Product Information — 6000 Series Motors

Specifications .....	51
Performance Data .....	52-53
Dimensions — Standard and Wheel Mount .....	54-55
Dimensions — Global Mount (Similar to ISO 3019/2) .....	56
Dimensions — Bearingless .....	57
Installation Information — Bearingless Motor .....	58
Dimensions — Shafts .....	59
Shaft Side Load — Standard and Wheel .....	60
Dimensions — Ports .....	61
Product Numbers .....	62
Model Code .....	63

## Product Information — 10 000 Series Motors

Specifications .....	64
Performance Data .....	65-66
Dimensions — Standard and Wheel Mount .....	67-68
Dimensions — Bearingless .....	69
Installation Information — Bearingless Motor .....	70
Dimensions — Shafts .....	71
Shaft Side Load — Standard and Wheel .....	72
Dimensions — Ports .....	73
Product Numbers .....	74
Model Code .....	75
Two Speed Motor .....	76
Two Speed Motor Circuit .....	77
Two Speed Motor Specifications .....	78
Two Speed Motor Dimensions .....	79
Two Speed Motor Product Numbers .....	80

## Fluid Recommendations

Char-Lynn Disc Valve Motors .....	81
-----------------------------------	----

## Motor Application Information

Vehicle Drive Calculations .....	82-83
----------------------------------	-------

# Specifications

## 2000 Series

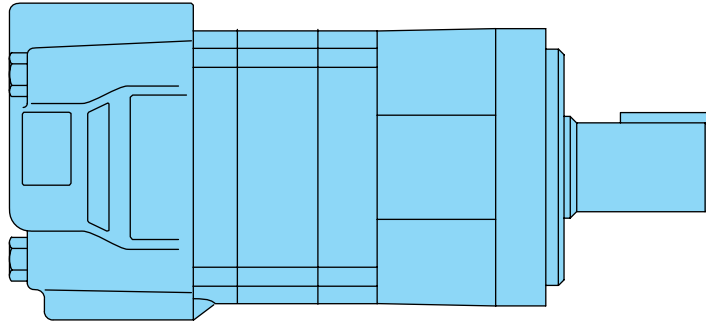

### Specification Data—2000 Series

Displ. cm <sup>3</sup> /r [in <sup>3</sup> /r]		80 [4.9]	100 [ 6.2]	130 [ 8.0]	160 [ 9.6]	195 [11.9]	245 [14.9]	305 [18.7]	395 [24.0]	490 [29.8]	
Max. Speed (RPM) @ ..... Flow	Continuous	799	742	576	477	385	308	246	191	153	
	Intermittent	908	924	720	713	577	462	365	287	230	
Flow LPM [GPM]	Continuous	75 [20]	75 [20]	75 [20]	75 [20]	75 [20]	75 [20]	75 [20]	75 [20]	75 [20]	
	Intermittent	75 [20]	95 [25]	95 [25]	115 [30]	115 [30]	115 [30]	115 [30]	115 [30]	115 [30]	
Torque Nm [lb-in]	☆ 1-1/4 Inch or 32 mm Dia. Shaft	Continuous	235 [2065]	295 [2630]	385 [3420]	455 [4040]	540 [4780]	660 [5850]	765 [6750]	775 [6840]	845 [7470]
		Intermittent	345 [3035]	445 [3950]	560 [4970]	570 [5040]	665 [5890]	820 [7250]	885 [7820]	925 [8170]	930 [8225]
Pressure Δ Bar [Δ PSI]	☆ 1-1/4 Inch or 32 mm Dia. Shaft	Continuous	205 [3000]	205 [3000]	205 [3000]	205 [3000]	205 [3000]	205 [3000]	205 [3000]	155 [2250]	120 [1750]
		Intermittent	310 [4500]	310 [4500]	310 [4500]	260 [3750]	260 [3750]	260 [3750]	240 [3500]	190 [2750]	140 [2000]
		Peak	310 [4500]	310 [4500]	310 [4500]	310 [4500]	310 [4500]	310 [4500]	310 [4500]	225 [3250]	170 [2500]

Maximum Case Pressure - without Case Drain \* — 140 Bar [2000 PSI]

**A simultaneous maximum torque and maximum speed NOT recommended.** For permissible continuous and intermittent operating combinations of pressure and flow refer to performance data on pages 15-19.

☆ **Maximum torque for 1 inch shaft** — 395 Nm [3500 lb-in] Continuous and 485 Nm [4300 lb-in] intermittent.

\* For back pressure over 140 Bar [2000 PSI] use an external case drain. Install case drain lines so that the motor case remains filled at all times.

**Maximum inlet pressure** — 310 Bar [4500 PSI]. Do not exceed Δ pressure rating (see chart above).

\* **Maximum return pressure** — 310 Bar [4500 PSI]. Do not exceed Δ pressure rating (see chart above).

**Δ Bar [Δ PSI]** — True pressure difference between inlet port and outlet port.

**Continuous Rating** — Motor may be run continuously at these ratings.

**Intermittent Operation** — 10% of every minute.

**Peak Operation** — 1% of every minute.

**Recommended Fluids** — Premium quality, anti-wear type hydraulic oil with a viscosity of not less than 70 SUS at operating temperature (see page 81).

**Recommended Maximum System Operating Temp.** — Is 82° C [180° F]

**Recommended Filtration** — per ISO Cleanliness Code, level 18/13

To assure best motor life, run motor for approximately one hour at 30% of rated pressure before application to full load. Be sure motor is filled with fluid prior to any load applications.

# Performance Data 2000 Series

Motors run with high efficiency in all areas designated with a number for torque and speed, however for best motor life select a motor to run with a torque and speed range shown in the light blue area.

80 cm<sup>3</sup>/r [4.9 in<sup>3</sup>/r]  
Δ Pressure Bar [PSI]

	[500]	[1000]	[1500]	[2000]	[2500]	[3000]	[3500]	[4000]	[4500]
	35	70	105	140	170	205	240	275	310
[.25]	[210]	[420]							
.95	25 3	45 1							
[.5]	[250]	[500]	[740]						
1.9	30 17	50 8	85 3						
[1]	[330]	[670]	[990]	[1300]	[1550]	[1800]	[1950]	[2110]	
3.8	35 44	75 40	110 37	145 34	175 28	205 22	220 14	240 2	
[2]	[330]	[670]	[995]	[1310]	[1580]	[1840]	[2100]	[2365]	[2630]
7.5	35 90	75 85	110 81	145 78	180 72	210 65	235 57	265 49	295 42
[4]	[325]	[670]	[1005]	[1330]	[1620]	[1920]	[2200]	[2480]	[2765]
15	35 182	75 170	115 170	150 166	185 159	215 152	250 140	280 128	310 117
[6]	[320]	[665]	[1010]	[1340]	[1655]	[1975]	[2270]	[2570]	[2880]
23	35 273	75 267	115 259	150 254	185 246	225 238	255 223	290 207	325 192
[8]	[310]	[660]	[1015]	[1345]	[1685]	[2020]	[2330]	[2640]	[2960]
30	35 365	75 375	115 349	150 341	190 333	230 325	265 306	300 286	335 266
[10]	[300]	[650]	[1010]	[1350]	[1700]	[2050]	[2370]	[2690]	[3010]
38	35 456	75 448	115 439	155 429	190 420	230 411	270 388	305 364	340 341
[12]	[285]	[640]	[1005]	[1350]	[1705]	[2065]	[2390]	[2715]	[3035]
45	30 547	70 537	115 530	155 516	195 507	235 497	270 470	305 442	345 415
[14]	[270]	[625]	[990]	[1340]	[1705]	[2065]	[2395]	[2720]	[3030]
53	30 638	70 629	110 622	150 603	195 593	235 584	270 553	305 521	340 490
[16]	[255]	[610]	[975]	[1330]	[1690]	[2055]	[2385]	[2700]	[2995]
61	30 729	70 720	110 714	150 689	190 679	230 670	270 635	305 599	340 564
[18]	[230]	[590]	[955]	[1310]	[1680]	[2025]	[2355]	[2660]	[2935]
68	25 818	65 810	110 795	150 775	190 765	230 756	265 717	300 677	330 638
[20]	[210]	[570]	[930]	[1290]	[1645]	[1985]	[2305]	[2600]	[2845]
76	25 908	65 901	105 880	145 861	185 851	225 842	260 799	295 755	320 712

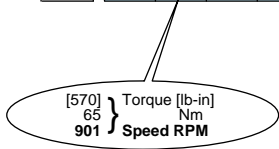

Continuous  
Intermittent

100 cm<sup>3</sup>/r [6.2 in<sup>3</sup>/r]  
Δ Pressure Bar [PSI]

	[250]	[500]	[1000]	[1500]	[2000]	[2500]	[3000]	[3500]	[4000]	[4500]
	15	35	70	105	140	170	205	240	275	310
[.25]	[140]	[260]								
.95	15 4	30 2								
[.5]	[150]	[300]	[620]	[940]						
1.9	15 13	35 9	70 5	105 2						
[1]	[170]	[390]	[830]	[1210]	[1570]	[1870]	[2130]			
3.8	20 35	45 34	95 31	135 28	175 23	210 15	240 6			
[2]	[170]	[390]	[830]	[1220]	[1590]	[1920]	[2220]	[2520]	[2810]	[3120]
7.5	20 73	45 71	95 68	140 63	180 59	215 51	250 38	285 24	315 14	355 4
[4]	[170]	[380]	[820]	[1240]	[1640]	[2010]	[2380]	[2750]	[3120]	[3490]
15	20 148	45 145	90 141	140 136	185 131	225 121	270 104	310 94	355 80	395 69
[6]	[160]	[380]	[820]	[1260]	[1670]	[2080]	[2480]	[2880]	[3280]	[3680]
23	20 222	45 219	90 215	140 209	190 202	235 192	280 172	325 163	370 149	415 134
[8]	[150]	[370]	[810]	[1260]	[1700]	[2130]	[2560]	[2990]	[3420]	[3840]
30	15 297	40 294	90 288	140 281	190 273	240 261	290 243	340 231	385 216	435 200
[10]	[140]	[368]	[810]	[1270]	[1720]	[2160]	[2610]	[3020]	[3440]	[3850]
38	15 371	40 362	90 354	145 344	195 330	245 316	295 300	345 283	390 266	435 226
[12]	[120]	[350]	[800]	[1270]	[1730]	[2180]	[2630]	[3070]	[3510]	[3950]
45	15 445	40 442	90 436	145 427	195 415	245 399	295 389	345 369	395 350	445 332
[14]	[110]	[330]	[800]	[1260]	[1740]	[2180]	[2630]	[3070]	[3500]	[3940]
53	10 519	35 516	90 509	140 500	195 486	245 469	295 463	345 437	395 417	445 378
[16]	[90]	[320]	[780]	[1260]	[1720]	[2160]	[2610]	[3060]	[3500]	[3940]
61	10 594	35 591	90 583	140 573	195 558	245 540	295 537	345 506	395 485	445 463
[18]	[70]	[300]	[770]	[1240]	[1700]	[2140]	[2580]	[3020]	[3460]	[3900]
68	10 668	35 665	85 657	140 646	190 630	240 611	290 609	340 574	390 552	440 529
[20]	[60]	[280]	[730]	[1180]	[1630]	[2090]	[2550]	[2980]	[3440]	[3830]
76	5 742	30 739	80 731	135 715	185 703	235 684	290 662	335 643	390 619	435 595
[22]	[40]	[260]	[720]	[1180]	[1620]	[2070]	[2500]	[2930]	[3360]	
83	5 816	30 813	80 805	135 794	185 777	235 758	280 749	330 712	380 687	
[24]	[20]	[230]	[690]	[1140]	[1540]	[2020]	[2460]	[2900]	[3340]	
91	1.0 890	230 887	80 879	130 868	175 852	230 834	280 814	330 782	375 754	
[25]		[220]	[670]	[1120]	[1560]	[1990]	[2450]	[2890]		
95		25 924	75 916	125 905	175 890	225 873	275 846	325 817		

Performance data is typical at 120 SUS. Actual data may vary slightly from unit to unit in production

# Performance Data 2000 Series

Motors run with high efficiency in all areas designated with a number for torque and speed, however for best motor life select a motor to run with a torque and speed range shown in the light blue area.

130 cm<sup>3</sup>/r [8.0 in<sup>3</sup>/r]  
Δ Pressure Bar [PSI]

160 cm<sup>3</sup>/r [9.6 in<sup>3</sup>/r]  
Δ Pressure Bar [PSI]

	[250] 15	[500] 35	[1000] 70	[1500] 105	[2000] 140	[2500] 170	[3000] 205	[3500] 240	[4000] 275	[4500] 310
[.25] <b>.95</b>	[170] 20 3									
[.5] <b>1.9</b>	[190] 20 12	[410] 45 8	[870] 100 2							
[1] <b>3.8</b>	[230] 25 28	[510] 60 27	[1070] 120 23	[1580] 180 19	[2050] 230 16	[2520] 285 13	[2920] 330 9	[3310] 375 3		
[2] <b>7.5</b>	[230] 25 56	[510] 60 56	[1080] 120 53	[1600] 180 47	[2090] 235 42	[2580] 290 39	[2930] 330 36	[3320] 375 28	[3640] 410 21	[3990] 450 13
[4] <b>15</b>	[220] 25 114	[500] 60 113	[1080] 120 111	[1620] 185 104	[2150] 245 97	[2660] 300 95	[3100] 350 92	[3540] 400 85	[3980] 450 77	[4420] 500 70
[6] <b>23</b>	[220] 25 172	[490] 60 171	[1080] 120 169	[1640] 185 161	[2190] 245 153	[2740] 310 149	[3260] 370 146	[3770] 425 132	[4280] 485 118	[4800] 540 104
[8] <b>30</b>	[200] 25 230	[480] 60 224	[1080] 120 222	[1650] 185 219	[2220] 250 210	[2780] 315 204	[3310] 375 201	[3840] 435 192	[4360] 495 184	[4890] 550 175
[10] <b>38</b>	[180] 20 287	[470] 55 286	[1070] 120 282	[1650] 185 276	[2230] 250 269	[2800] 315 261	[3420] 385 255	[3940] 445 243	[4450] 505 231	[4970] 560 219
[12] <b>45</b>	[160] 20 345	[460] 50 344	[1060] 120 338	[1640] 185 333	[2230] 250 327	[2800] 315 317	[3350] 380 307	[3910] 440 295	[4440] 500 284	[4960] 560 272
[14] <b>53</b>	[150] 15 403	[440] 50 402	[1030] 115 395	[1620] 185 391	[2220] 250 385	[3000] 340 373	[3350] 380 360	[3910] 440 348	[4440] 500 336	
[16] <b>61</b>	[130] 15 461	[420] 45 460	[1010] 115 452	[1600] 180 447	[2200] 245 443	[2780] 315 430	[3330] 375 411	[3890] 440 397	[4440] 500 384	
[18] <b>68</b>	[110] 10 518	[400] 45 517	[990] 110 509	[1580] 180 504	[2160] 245 500	[2750] 310 484	[3300] 375 471	[3860] 435 456	[4410] 500 440	
[20] <b>76</b>	[90] 10 576	[380] 45 575	[960] 110 568	[1550] 175 560	[2130] 240 551	[2710] 305 539	[3280] 370 524	[3840] 435 508		
[22] <b>83</b>	[60] 5 634	[350] 40 633	[940] 105 624	[1520] 170 619	[2100] 235 604	[2680] 305 597	[3250] 365 579	[3820] 430 560		
[24] <b>91</b>	[40] 5 692	[325] 35 691	[920] 105 682	[1490] 170 676	[2070] 235 665	[2650] 300 651	[3220] 365 633	[3780] 425 616		
[25] <b>95</b>	[20] 1.0 720	[310] 35 719	[900] 100 712	[1480] 165 705	[2050] 230 692	[2630] 295 679	[3200] 360 682	[3700] 420 656		

	[250] 15	[500] 35	[1000] 70	[1500] 105	[2000] 140	[2500] 170	[3000] 205	[3500] 240	[3750] 260
[.25] <b>.95</b>	[200] 25 3								
[.5] <b>1.9</b>	[240] 25 9	[490] 55 7	[990] 110 5	[1570] 175 3	[2140] 240 1				
[1] <b>3.8</b>	[280] 30 23	[590] 65 21	[1170] 130 19	[1730] 195 17	[2290] 260 13	[2830] 320 8	[3330] 375 3	[3820] 430 2	[4070] 460 1
[2] <b>7.5</b>	[300] 35 46	[610] 70 45	[1210] 135 42	[1790] 200 39	[2350] 265 35	[2920] 330 34	[3480] 395 33	[4050] 460 28	[4330] 490 22
[4] <b>15</b>	[320] 35 93	[630] 70 92	[1260] 140 89	[1890] 215 85	[2530] 285 79	[3170] 360 77	[3820] 430 75	[4460] 505 59	[4780] 540 43
[6] <b>23</b>	[320] 35 142	[650] 75 140	[1300] 145 137	[1960] 220 131	[2620] 295 124	[3280] 370 118	[3940] 445 113	[4600] 520 104	[4930] 560 96
[8] <b>30</b>	[310] 35 190	[650] 75 187	[1330] 150 184	[2010] 225 178	[2670] 300 170	[3330] 375 166	[4000] 450 164	[4660] 525 153	[4990] 565 142
[10] <b>38</b>	[290] 35 237	[640] 70 235	[1340] 150 231	[2030] 230 226	[2850] 320 212	[3410] 385 212	[4030] 455 205	[4700] 530 193	[5030] 570 187
[12] <b>45</b>	[270] 30 286	[620] 70 283	[1320] 150 279	[2030] 230 274	[2700] 305 265	[3370] 380 254	[4040] 445 246	[4710] 530 235	[5040] 570 224
[14] <b>53</b>	[240] 25 334	[590] 65 331	[1300] 145 326	[2020] 230 322	[2690] 305 312	[3360] 380 305	[4030] 455 297	[4700] 530 286	
[16] <b>61</b>	[220] 25 382	[570] 65 378	[1270] 145 374	[1980] 225 369	[2850] 300 360	[3330] 375 349	[4030] 455 339	[4680] 530 326	
[18] <b>68</b>	[190] 20 429	[540] 60 426	[1240] 140 422	[1960] 220 416	[2640] 300 407	[3320] 375 394	[3990] 445 387		
[20] <b>76</b>	[170] 20 477	[510] 60 474	[1210] 135 469	[1920] 215 462	[2630] 300 451	[3310] 375 440	[3940] 445 430		
[22] <b>83</b>	[150] 15 525	[480] 55 522	[1170] 130 517	[1880] 210 510	[2600] 295 501	[3290] 370 484	[3920] 445 473		
[24] <b>91</b>	[120] 15 572	[450] 50 569	[1150] 130 564	[1860] 210 556	[2570] 290 546	[3260] 370 531	[3900] 440 522		
[25] <b>95</b>	[90] 10 596	[440] 50 593	[1140] 130 587	[1840] 210 580	[2560] 290 566	[3230] 365 553	[3880] 440 544		
[30] <b>114</b>		[330] 35 713	[1040] 120 706	[1750] 200 696	[2470] 280 682	[3140] 355 672	[3800] 430 658		

[330]  
35  
713 } Torque [lb-in]  
Nm  
Speed RPM

Continuous  
Intermittent

Performance data is typical at 120 SUS. Actual data may vary slightly from unit to unit in production





### Disc Valve Hydraulic Motors

# Performance Data 2000 Series

305 cm<sup>3</sup>/r [18.7 in<sup>3</sup>/r]  
 $\Delta$  Pressure Bar [PSI]

	[250] 15	[500] 35	[750] 50	[1000] 70	[1250] 85	[1500] 105	[1750] 120	[2000] 140	[2250] 155	[2500] 170	[2750] 190	[3000] 205	[3250] 225	[3500] 240
[.5] <b>1,9</b>	[500] 55 4	[1050] 120 2												
[1] <b>3,8</b>	[610] 70 12	[1180] 135 11	[1750] 200 11	[2330] 260 10	[2870] 325 10	[3440] 390 9	[3930] 445 8	[4410] 500 6	[4900] 555 3	[5380] 610 1				
[2] <b>7,5</b>	[620] 70 24	[1210] 135 24	[1800] 205 23	[2400] 270 22	[2970] 335 22	[3510] 395 20	[4050] 460 19	[4600] 520 18	[5140] 580 17	[5680] 640 15	[6220] 705 13	[6750] 765 11	[7290] 825 8	[7820] 885 6
[4] <b>15</b>	[680] 75 49	[1250] 140 49	[1880] 210 48	[2500] 280 47	[3120] 355 47	[3690] 415 45	[4260] 480 43	[4840] 545 42	[5410] 610 40	[5980] 675 38	[6550] 740 36	[7120] 805 34	[7690] 870 33	
[6] <b>23</b>	[620] 70 74	[1270] 145 74	[1920] 215 72	[2560] 290 71	[3230] 365 69	[3810] 430 66	[4390] 495 64	[4970] 560 61	[5560] 630 58	[6130] 695 55	[6710] 760 52	[7290] 825 52		
[8] <b>30</b>	[600] 70 98	[1270] 145 98	[1940] 220 97	[2600] 295 96	[3290] 370 95	[3880] 440 93	[4470] 505 90	[5070] 575 86	[5660] 640 83	[6250] 705 80	[6840] 775 77			
[10] <b>38</b>	[570] 65 123	[1250] 140 122	[1940] 220 121	[2610] 295 120	[3310] 375 119	[3920] 440 117	[4530] 510 113	[5150] 580 110	[5760] 650 106	[6370] 720 102				
[12] <b>45</b>	[530] 60 148	[1220] 140 147	[1920] 215 145	[2600] 295 144	[3300] 375 143	[3920] 440 142	[4530] 510 138	[5150] 580 133	[5760] 650 128	[6370] 720 124				
[14] <b>53</b>	[480] 55 172	[1180] 135 172	[1870] 210 170	[2560] 290 168	[3260] 370 167	[3900] 440 165	[4510] 510 160	[5120] 580 156	[5730] 645 152					
[16] <b>61</b>	[430] 50 196	[1120] 125 196	[1820] 205 194	[2500] 280 192	[3210] 365 191	[3870] 440 188	[4480] 505 183	[5080] 575 178	[5690] 645 174					
[18] <b>68</b>	[370] 40 221	[1060] 120 221	[1760] 200 218	[2440] 275 217	[3140] 355 215	[3800] 440 212	[4420] 500 207	[5050] 570 202						
[20] <b>76</b>	[320] 35 246	[980] 110 245	[1680] 190 243	[2360] 265 241	[3050] 345 239	[3710] 420 236	[4370] 495 231	[5020] 565 226						
[22] <b>83</b>	[240] 25 25	[920] 105 270	[1620] 185 268	[2300] 260 266	[2990] 340 263	[3560] 400 260	[4190] 475 258	[4820] 545 255						
[24] <b>91</b>	[180] 20 296	[870] 100 294	[1550] 175 293	[2240] 255 290	[2920] 330 288	[3420] 385 285	[4020] 455 283	[4630] 525 280						
[25] <b>95</b>	[150] 15 308	[840] 95 307	[1520] 170 305	[2200] 250 303	[2890] 325 300	[3340] 375 298	[3930] 445 295	[4520] 510 293						
[30] <b>114</b>	[680] 75 365	[1360] 155 362	[2040] 230 360	[2720] 305 357	[3140] 355 356	[3810] 430 352								

[2040]  
230  
360 } Torque [lb-in]  
                        Nm  
                        Speed RPM

  Continuous  
  Intermittent

Motors run with high efficiency in all areas designated with a number for torque and speed, however for best motor life select a motor to run with a torque and speed range shown in the light blue area.

395 cm<sup>3</sup>/r [24.0 in<sup>3</sup>/r]  
 $\Delta$  Pressure Bar [PSI]

	[250] 15	[500] 35	[750] 50	[1000] 70	[1250] 85	[1500] 105	[1750] 120	[2000] 140	[2250] 155	[2500] 170	[2750] 190
[.5] <b>1,9</b>	[560] 65 4	[1310] 150 3									
[1] <b>3,8</b>	[770] 85 9	[1540] 175 9	[2290] 260 9	[3080] 350 8	[3780] 430 8	[4480] 505 7	[5170] 585 7	[5880] 665 6	[6580] 745 5	[7270] 820 4	[7980] 900 3
[2] <b>7,5</b>	[790] 90 18	[1580] 180 18	[2360] 265 18	[3180] 360 17	[3930] 445 17	[4680] 530 16	[5430] 615 16	[6180] 700 14	[6840] 775 14	[7500] 845 13	[8170] 925 11
[4] <b>15</b>	[810] 90 37	[1660] 190 37	[2480] 280 37	[3320] 375 36	[4130] 465 36	[4940] 560 35	[5740] 650 34	[6550] 740 33	[7230] 815 31	[7880] 890 28	
[6] <b>23</b>	[820] 90 57	[1700] 190 56	[2550] 290 56	[3420] 385 55	[4250] 480 54	[5080] 575 52	[5920] 670 50	[6750] 765 49	[7420] 840 47	[8000] 905 45	
[8] <b>30</b>	[820] 90 76	[1700] 190 75	[2580] 290 75	[3460] 390 74	[4300] 485 73	[5130] 580 71	[5960] 675 69	[6800] 770 68			
[10] <b>38</b>	[800] 90 95	[1700] 190 94	[2590] 295 94	[3480] 395 93	[4320] 490 92	[5160] 585 90	[6000] 680 88	[6840] 775 86			
[12] <b>45</b>	[770] 85 114	[1680] 190 113	[2570] 290 113	[3470] 390 112	[4310] 485 111	[5150] 580 109	[5990] 675 106	[6830] 770 103			
[14] <b>53</b>	[740] 85 133	[1640] 185 132	[2530] 285 132	[3430] 390 131	[4280] 485 129	[5120] 580 127	[5960] 675 124				
[16] <b>61</b>	[690] 80 153	[1590] 180 152	[2480] 280 152	[3370] 380 150	[4220] 475 149	[5060] 570 146	[5910] 670 144				
[18] <b>68</b>	[640] 70 172	[1530] 170 171	[2420] 275 171	[3310] 375 170	[4160] 470 169	[5010] 565 167	[5870] 665 164				
[20] <b>76</b>	[580] 65 191	[1470] 165 190	[2370] 270 190	[3260] 370 189	[4110] 465 188	[4960] 560 186	[5820] 660 184				
[22] <b>83</b>	[510] 60 210	[1390] 155 209	[2290] 260 209	[3170] 360 208	[4030] 455 207	[4880] 550 206					
[24] <b>91</b>	[440] 50 230	[1330] 150 229	[2220] 250 228	[3100] 350 227	[3950] 445 225	[4800] 540 224					
[26] <b>98</b>	[350] 40 249	[1240] 140 248	[2130] 240 247	[3020] 340 246	[3880] 440 244	[4730] 535 242					
[28] <b>106</b>	[270] 30 268	[1150] 130 267	[2050] 230 265	[2930] 330 264	[3790] 430 261	[4650] 525 259					
[30] <b>114</b>	[180] 20 287	[1060] 120 286	[1960] 220 284	[2850] 320 283	[3710] 420 281	[4570] 515 277					

Performance data is typical at 120 SUS. Actual data may vary slightly from unit to unit in production

# Performance Data 2000 Series

490 cm<sup>3</sup>/r [29.8 in<sup>3</sup>/r]  
Δ Pressure Bar [PSI]

	[250] 15	[500] 35	[750] 50	[1000] 70	[1250] 85	[1500] 105	[1750] 120	[2000] 140
[.5] 1.9	[670] 75 2	[1600] 180 1						
[1] 3.8	[920] 105 7	[2000] 225 6	[2990] 340 5	[3900] 440 4	[4880] 550 2			
[2] 7.5	[950] 105 14	[2060] 235 13	[3110] 350 12	[4080] 460 10	[5110] 575 9	[6320] 715 7		
[4] 15	[980] 110 30	[2130] 240 29	[3230] 365 28	[4270] 480 27	[5350] 605 26	[6370] 720 24	[7380] 835 22	[7980] 900 20
[6] 23	[980] 110 45	[2120] 240 44	[3230] 365 43	[4300] 485 42	[5370] 605 41	[6420] 725 39	[7470] 845 37	[8225] 930 35
[8] 30	[980] 110 61	[2110] 240 60	[3220] 365 59	[4330] 490 58	[5400] 610 57	[6470] 730 55	[7550] 855 52	
[10] 38	[920] 105 76	[2050] 230 75	[3170] 360 74	[4300] 485 73	[5390] 610 72	[6460] 730 70	[7550] 855 68	
[12] 45	[860] 95 91	[1990] 225 90	[3120] 355 90	[4260] 480 89	[5370] 605 87	[6460] 730 85	[7560] 855 84	
[14] 53	[790] 90 106	[1930] 220 105	[3055] 345 105	[4185] 475 104	[5300] 600 102	[6400] 725 100		
[16] 61	[720] 80 122	[1870] 210 121	[2990] 340 120	[4110] 465 119	[5230] 590 118	[6340] 715 116		
[18] 68	[630] 70 137	[1770] 200 136	[2890] 325 135	[4020] 455 134	[5140] 580 133	[6260] 705 131		
[20] 76	[550] 60 153	[1670] 190 152	[2800] 315 151	[3940] 445 150	[5060] 570 149	[6180] 700 146		
[22] 83	[450] 50 168	[1570] 175 168	[2700] 305 167	[3830] 435 165	[4960] 560 164	[6070] 685 161		
[24] 91	[360] 40 184	[1480] 165 184	[2600] 295 183	[3730] 420 181	[4860] 550 179	[5970] 675 177		
[26] 98	[270] 30 199	[1390] 155 195	[2510] 285 194	[3640] 410 192	[4770] 540 190			
[28] 106		[1260] 140 212	[2370] 270 211	[3520] 400 209	[4630] 525 207			
[30] 114		[1130] 125 230	[2240] 255 229	[3400] 385 277	[4500] 510 224			

Motors run with high efficiency in all areas designated with a number for torque and speed, however for best motor life select a motor to run with a torque and speed range shown in the light blue area.

[1130]  
125  
230
 
 } Torque [lb-in]  
 Nm  
 Speed RPM

Continuous  
 Intermittent

Performance data is typical at 120 SUS. Actual data may vary slightly from unit to unit in production

# Dimensions — 2000 Series Standard Motor

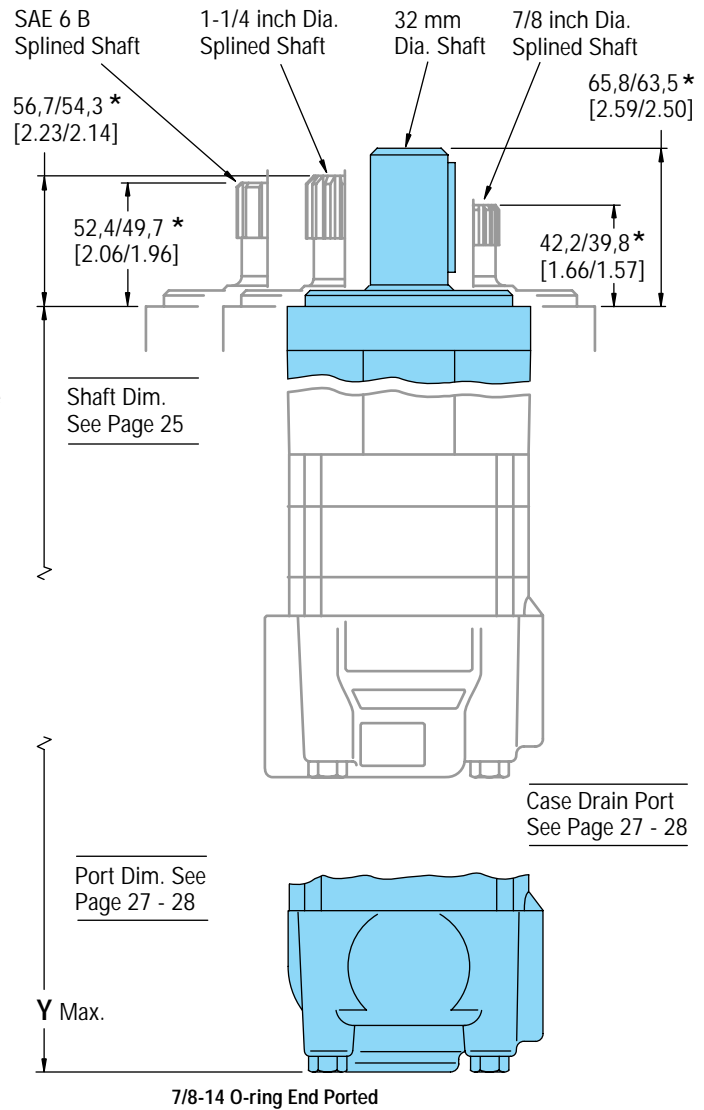
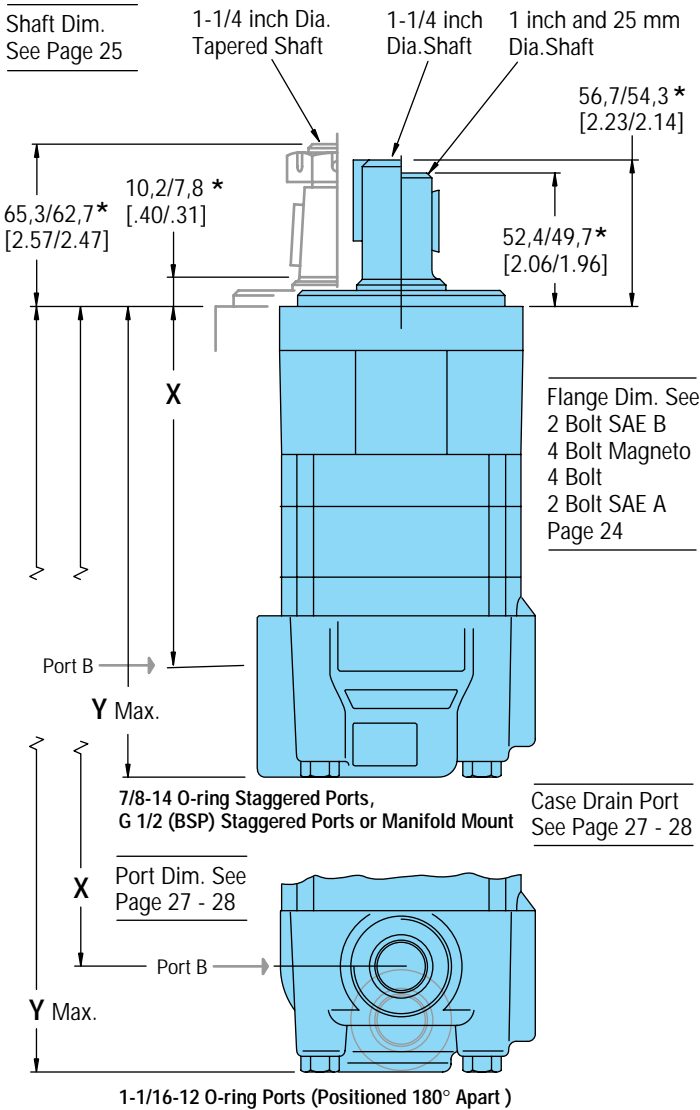

**2000 Series Standard Motor** with 7/8-14 O-ring Staggered Ports, G 1/2 (BSP) Staggered Ports or Manifold Mount

Displ. cm <sup>3</sup> /r [in <sup>3</sup> /r]	80 [4.9]	100 [6.2]	130 [8.0]	160 [9.6]	195 [11.9]	245 [14.9]	305 [18.7]	395 [24.0]	490 [29.8]
Dim. mm X	137,0	141,6	147,9	147,9	154,8	163,7	175,1	191,1	208,4
[inch]	[ 5.40]	[ 5.58]	[ 5.83]	[ 5.83]	[ 6.10]	[ 6.45]	[ 6.90]	[ 7.53]	[ 8.21]
Dim. mm Y	184,5	189,0	195,4	195,4	202,2	211,1	222,6	238,6	255,8
[inch]	[ 7.26]	[ 7.44]	[ 7.69]	[ 7.69]	[ 7.96]	[ 8.31]	[ 8.76]	[ 9.39]	[10.07]

**2000 Series Standard Motor** with 1-1/16-12 O-ring Ports (Positioned 180° Apart) and use Only Dim. Y for 7/8-14 O-ring End Ported Motors

Dim. mm X	139,3	143,9	150,2	150,2	157,1	166,0	177,4	193,4	210,7
[inch]	[ 5.49]	[ 5.67]	[ 5.92]	[ 5.92]	[ 6.19]	[ 6.54]	[ 6.99]	[ 7.62]	[ 8.30]
Dim. mm Y	185,7	190,3	196,6	196,6	203,5	212,4	223,8	239,8	270,1
[inch]	[ 7.31]	[ 7.49]	[ 7.74]	[ 7.74]	[ 8.01]	[ 8.36]	[ 8.81]	[ 9.44]	[10.12]

**Standard Rotation**  
Viewed from Shaft End  
Port A Pressurized — CW  
Port B Pressurized — CCW

**\*Subtract 4,1/3,6 [ .16/.14] when ordering motor with 4-bolt magneto flange**

# Dimensions — 2000 Series Wheel Motor

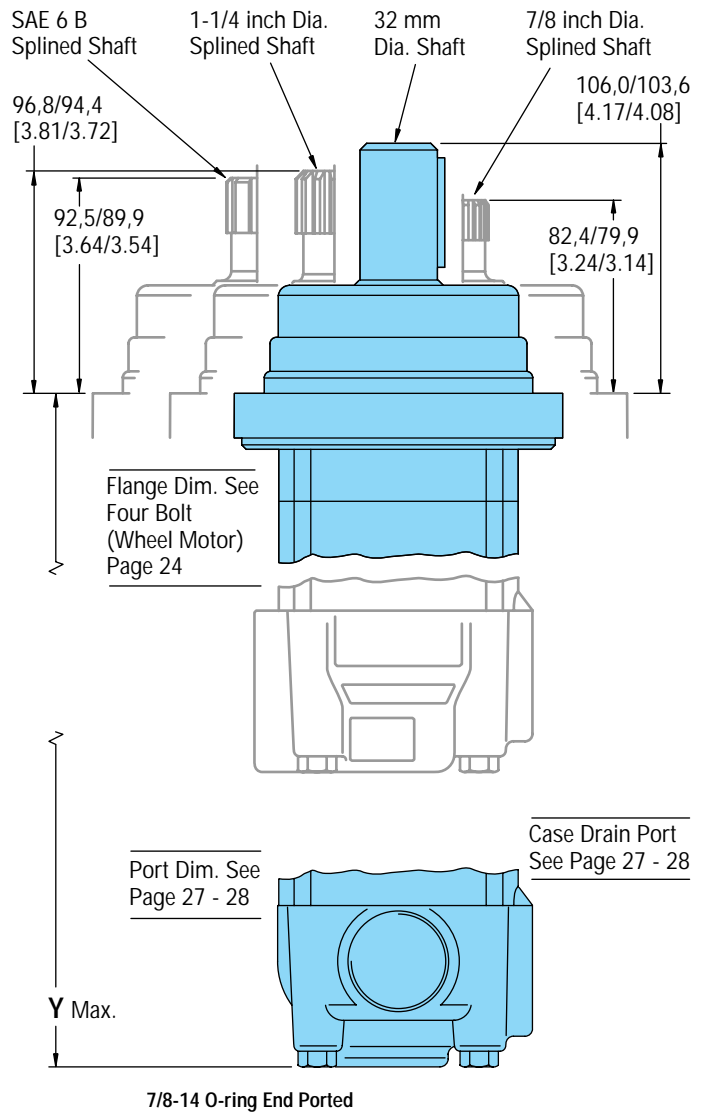
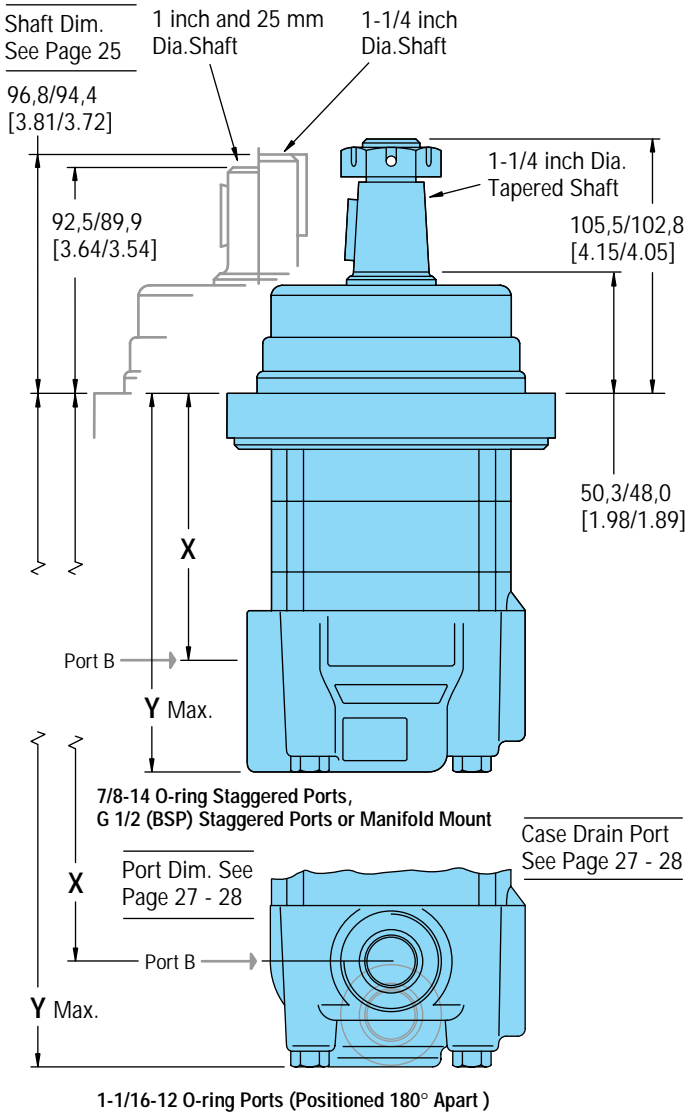

**2000 Series Wheel Motor** with 7/8-14 O-ring Staggered Ports,  
G 1/2 (BSP) Staggered Ports or Manifold Mount

Displ. cm <sup>3</sup> /r [in <sup>3</sup> /r]	80 [ 4.9]	100 [ 6.2]	130 [ 8.0]	160 [ 9.6]	195 [11.9]	245 [14.9]	305 [18.7]	395 [24.0]	490 [29.8]
Dim. mm	96,9	101,4	107,8	107,8	114,6	123,5	135,0	151,0	168,2
<b>X</b> [inch]	[ 3.82]	[ 4.00]	[ 4.25]	[ 4.25]	[ 4.52]	[ 4.87]	[ 5.32]	[ 5.95]	[ 6.63]
Dim. mm	144,3	148,9	155,2	155,2	162,1	171,0	182,4	198,4	215,7
<b>Y</b> [inch]	[ 5.68]	[ 5.86]	[ 6.11]	[ 6.11]	[ 6.38]	[ 6.73]	[ 7.18]	[ 7.81]	[ 8.49]

**2000 Series Wheel Motor** with 1-1/16-12 O-ring Ports (Positioned 180° Apart) and use Only Dim. Y for 7/8-14 O-ring End Ported Wheel Motors

Dim. mm	99,1	103,7	110,1	110,1	116,9	125,8	137,4	153,4	170,7
<b>X</b> [inch]	[ 3.90]	[ 4.09]	[ 4.34]	[ 4.34]	[ 4.61]	[ 4.96]	[ 5.41]	[ 6.04]	[ 6.72]
Dim. mm	145,6	150,2	156,5	156,5	163,4	172,3	183,7	199,7	217,0
<b>Y</b> [inch]	[ 5.73]	[ 5.91]	[ 6.16]	[ 6.16]	[ 6.43]	[ 6.78]	[ 7.23]	[ 7.86]	[ 8.54]

**Standard Rotation**  
Viewed from Shaft End  
Port A Pressurized — CW  
Port B Pressurized — CCW

# Dimensions — 2000 Series Bearingless Motor

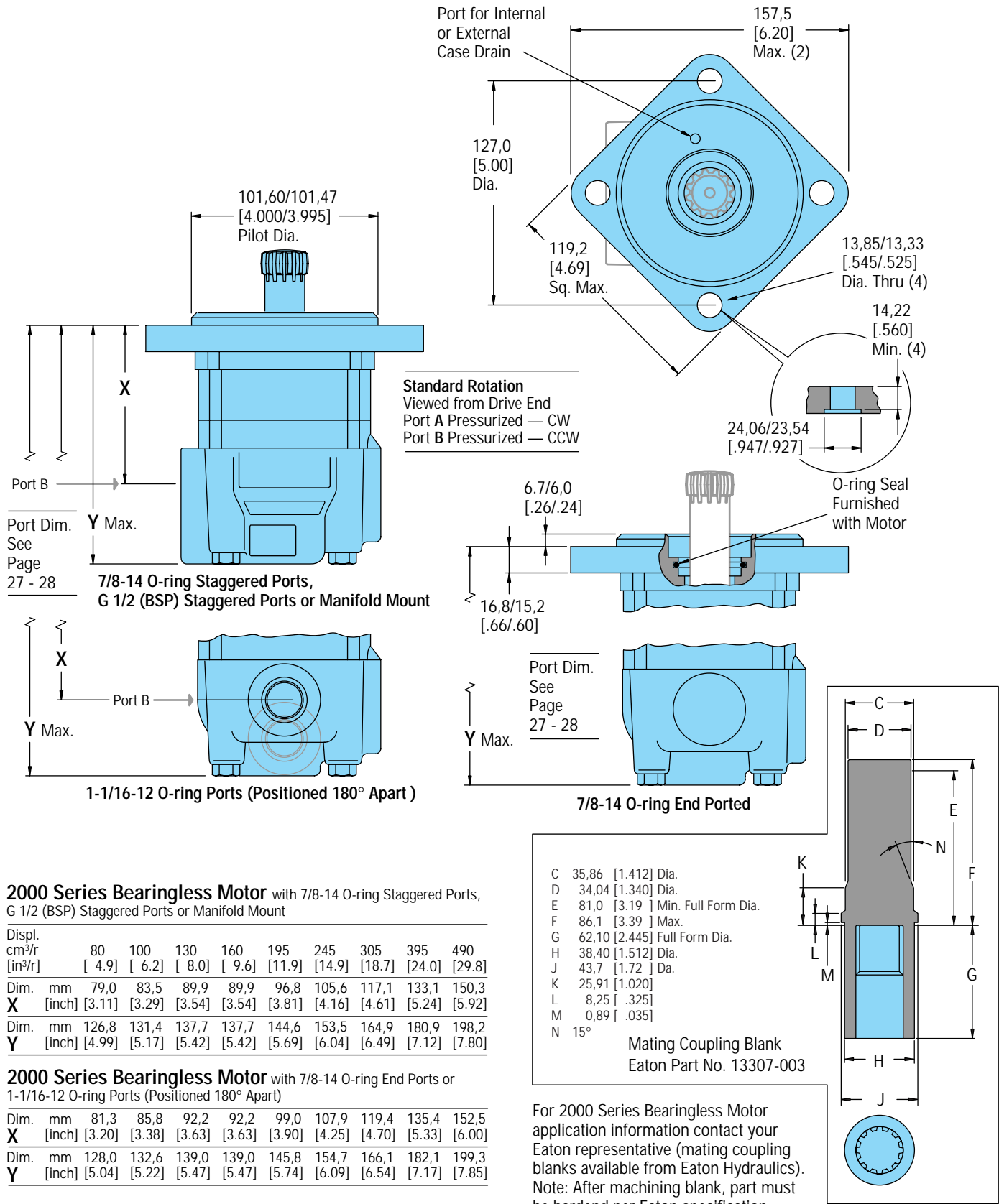

# Bearingless Installation — 2000 Series

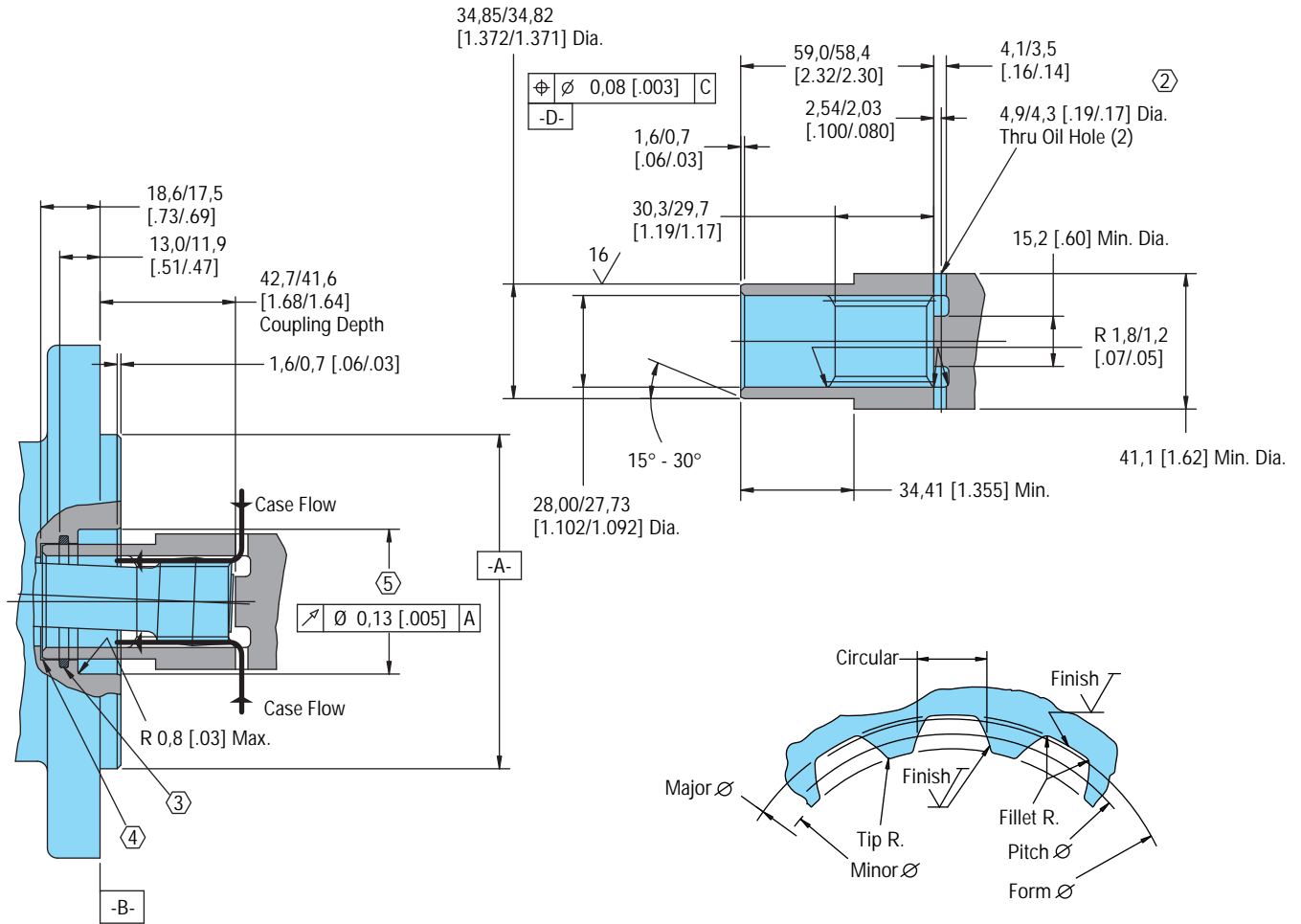

Spline Pitch — 12/24  
 Pressure Angle — 30°  
 Number of teeth — 12  
 Class of Fit — Ref. 5  
 Type of Fit — Side  
 Pitch Diameter — Ref. 25,400000 [1.000000]  $\text{C} \phi 0,21$  [.008] D  
 Base Diameter — Ref. 21,997045 [.8660254]  
 Major Diameter — (27,74 [1.092] Max. 27,59 [1.086] Min.)  
 Minor Diameter — 23,097 - 23,224 [.9093 - .9143]  
 Form Diameter, Min. — 29,93 [1.060]  
 Fillet Radius — 0,64 - 0,76 [.025 - .030]  
 Tip Radius — 0,25 - 0,38 [.010 - .015]  
 Finish — 1,6 (63)  
 Involute Profile Variation — +0,000 -0,025 [+0.0000 -0.0010]  
 Total Index Variation — 0,038 [.0015]  
 Lead Variation — 0,013 [.0005]  
 Circular Space Width:  
 Maximum Actual — 4,318 [.1700]  
 Minimum Effective — 4,216 [.1660]  
 Maximum Effective — Ref. 4,270 [.1681]  
 Minimum Actual — Ref. 4,247 [.1672]  
 Dimension Between Two Pins — Ref. 19,020 - 19,190 [.7488 - .7555]  
 Pin Diameter — 4,496 [.1770] Pins to Have 3,38 [.133] Wide Flat for Root Clearance

- 1 Internal spline in mating part to be per spline data. Specification material to be ASTM A304, 8620H vacuum degassed alloy steel carburize to a hardness of 59-62 HRC with case depth (to 50HRC) of 0,076 - 1,02 [.030 - .040]. Dimensions apply after heat treat.
- ② Mating part to have critical dimensions as shown. Oil holes must be provided and open for proper oil circulation.
- ③ Seal to be furnished with motor for proper oil circulation thru splines.
- ④ Some means of maintaining clearance between shaft and mounting flange must be provided.
- ⑤ Counterbore designed to adapt a standard sleeve bearing 35,010 - 35,040 [1.3784 - 1.3795] I.D. by 44,040 - 44,070 [1.7339 - 1.7350] O.D. (Oilite Bronze Sleeve Bearing AAM3544-22).

# Dimensions — Mounting Options 2000 Series

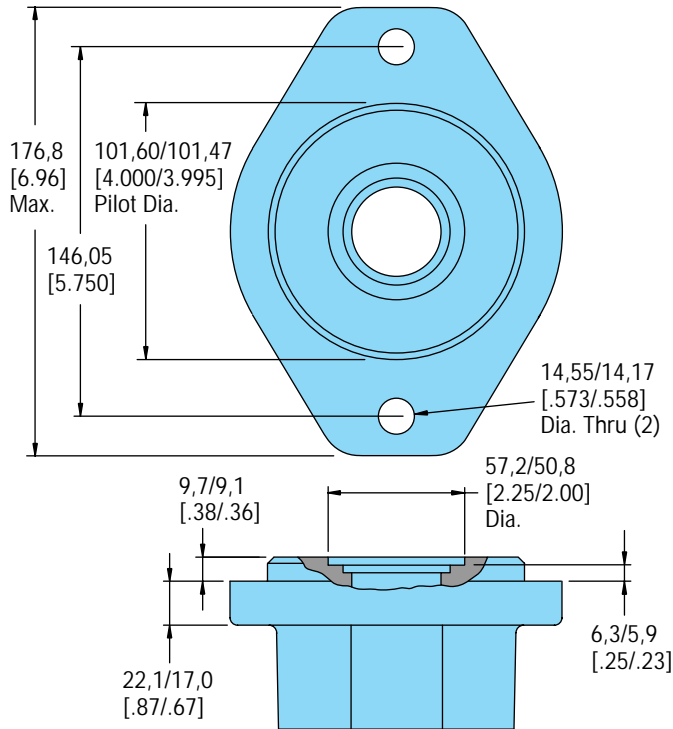

**2 Bolt SAE B**

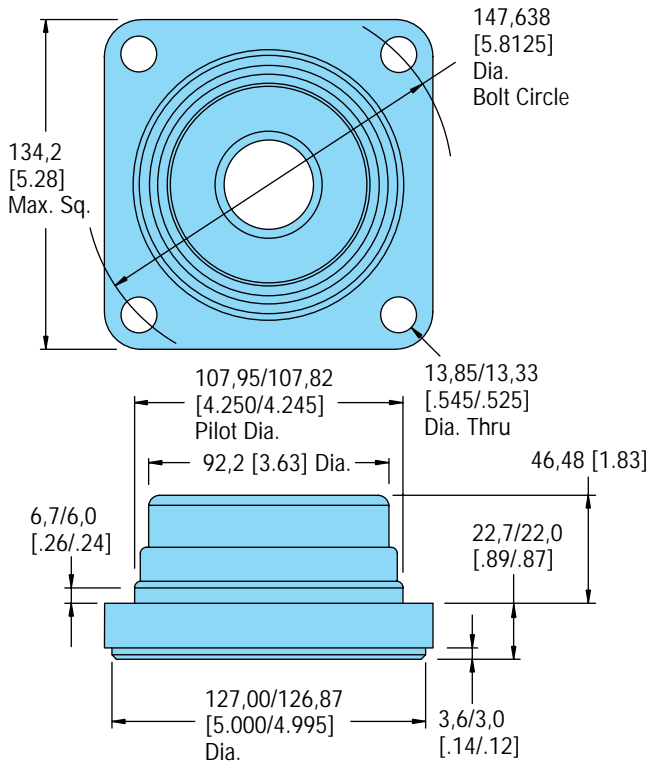

**Four Bolt (Wheel Motor)**

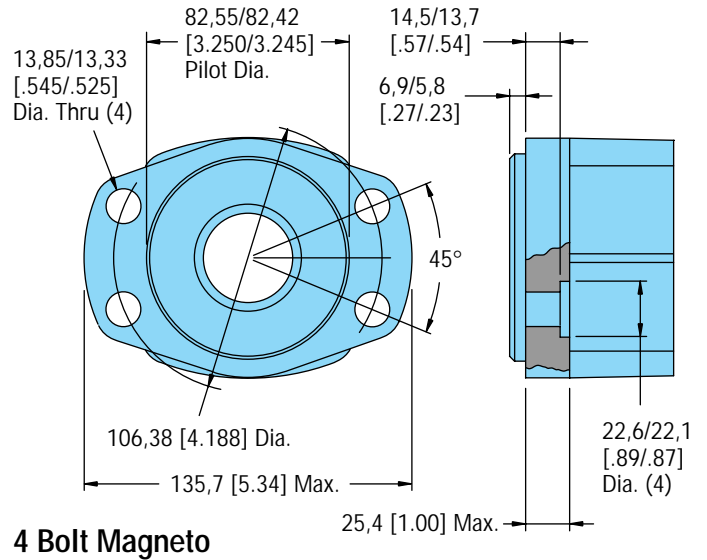

**4 Bolt Magneto**

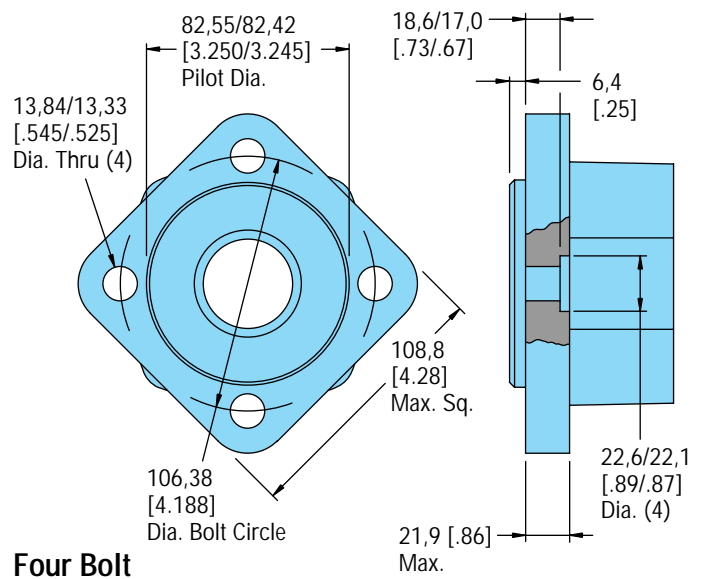

**Four Bolt**

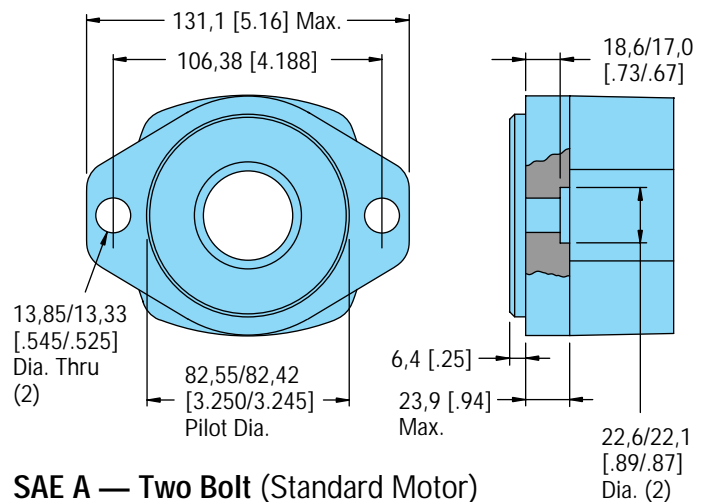

**SAE A — Two Bolt (Standard Motor)**



# Dimensions — Shafts

## 2000 Series

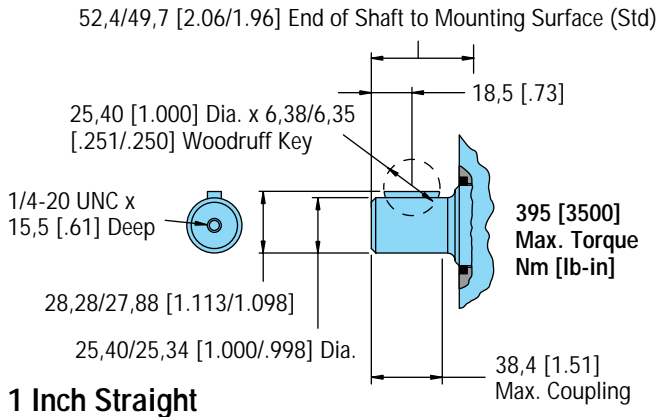

**1 Inch Straight**

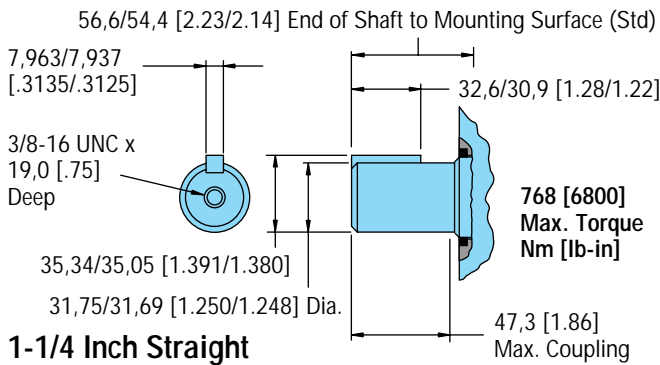

**1-1/4 Inch Straight**

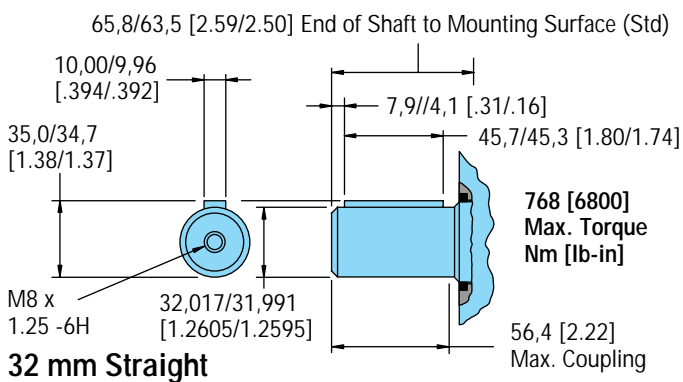

**32 mm Straight**

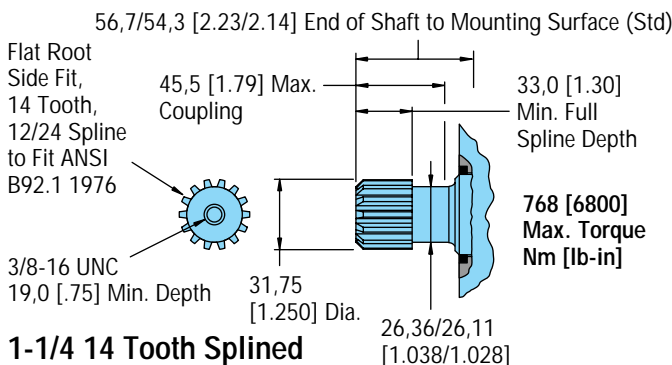

**1-1/4 14 Tooth Splined**

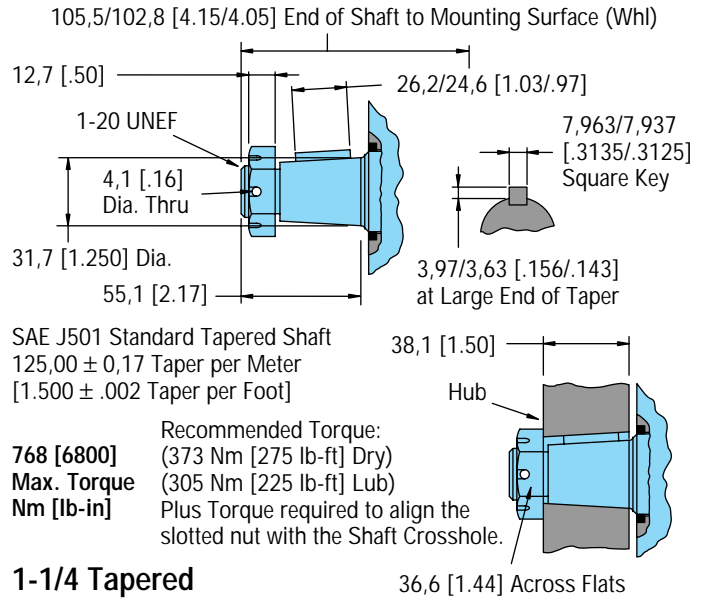

**1-1/4 Tapered**

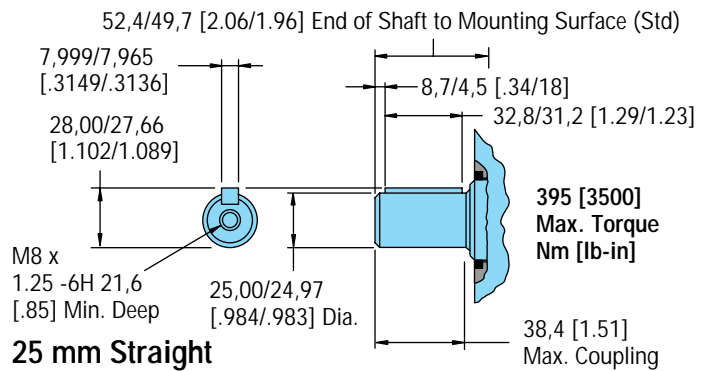

**25 mm Straight**

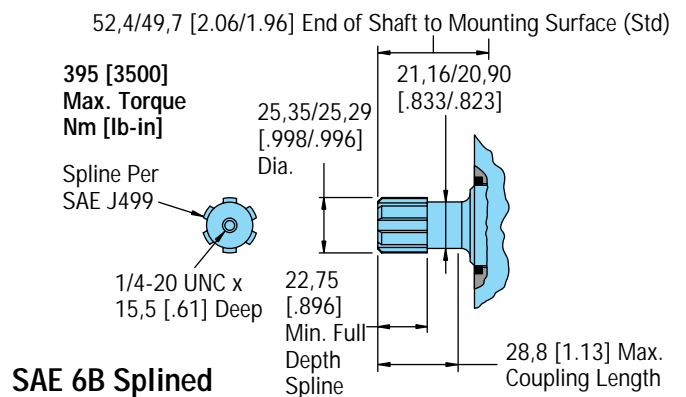

**SAE 6B Splined**

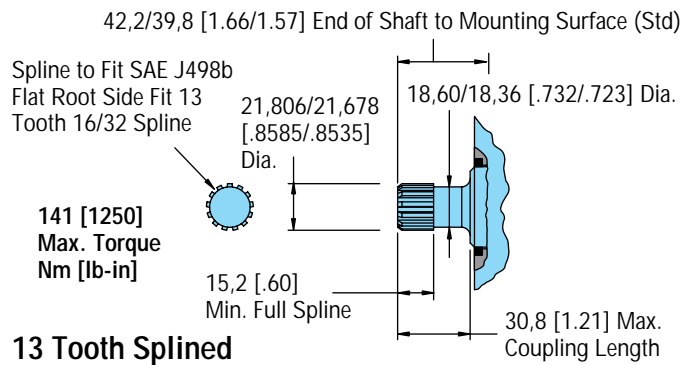

**13 Tooth Splined**

# Shaft Side Load Capacity 2000 Series

These curves indicate the radial load capacity on the motor shaft(s) at various locations.

The curve is based on B 10 Bearing life (2000 hours or 12,000,000 shaft revolutions at 100 RPM ) at rated output torque. To determine radial load at speeds other than 100 RPM, multiply the load values given on the bearing curve by the factors in the chart below.

RPM	Multiplication Factor
50	1.23
100	1.00
200	.81
300	.72
400	.66
500	.62
600	.58
700	.56
800	.54

For 3,000,000 Shaft revolutions or 500 hours — Increase these shaft loads 52%.

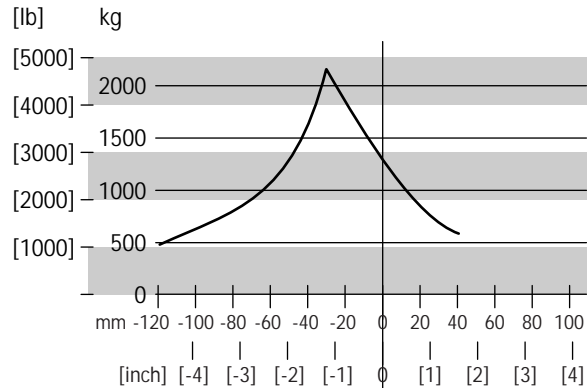

Wheel Motor  
Tapered  
Shaft

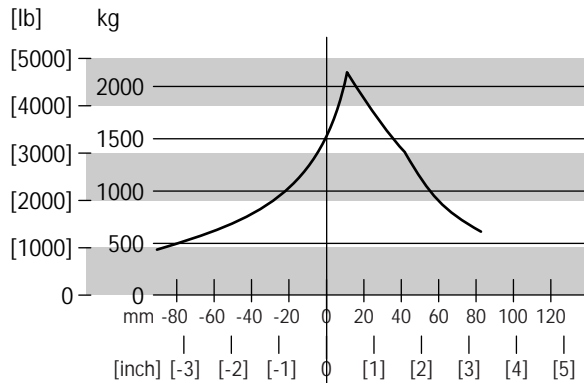
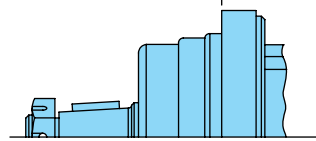

Standard Motor  
1-1/4 Inch and  
32 mm Straight  
Shaft

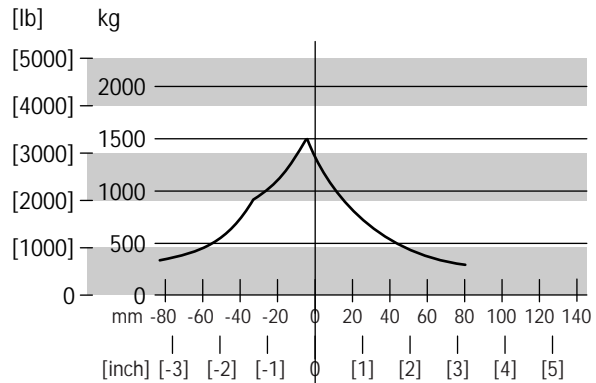
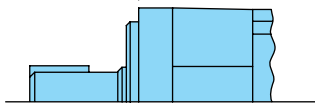

Standard Motor  
1 Inch Straight  
Shaft

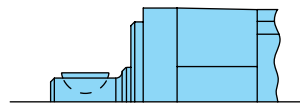

# Dimensions — Ports 2000 Series

**Standard Rotation — 2000 Series**  
Viewed from Shaft End  
Port A Pressurized — CW  
Port B Pressurized — CCW

**7/8-14 O-ring Ports (2)  
or G 1/2 (BSP) Ports (2)**

**Case Drain Location —  
Staggered Ports  
(Including  
Manifold Mount)**

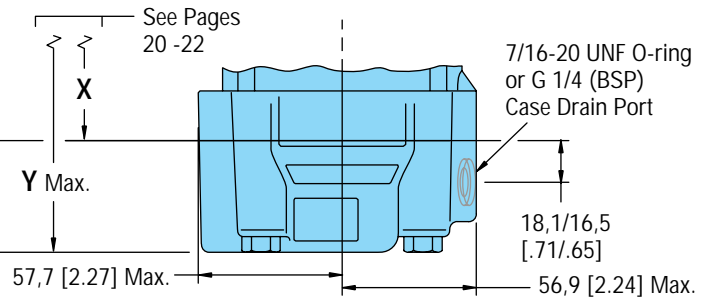
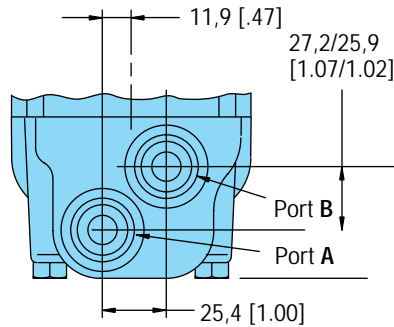
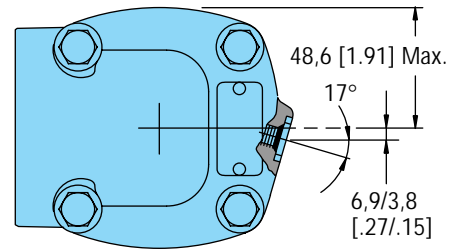

**Manifold Mount**

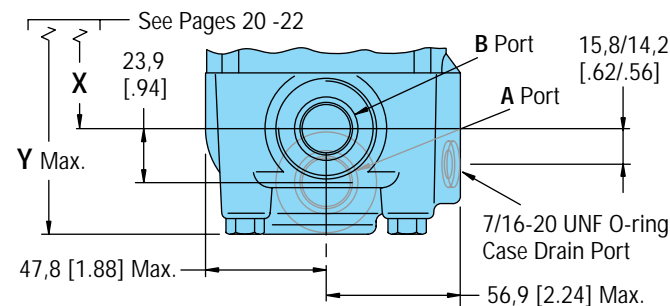
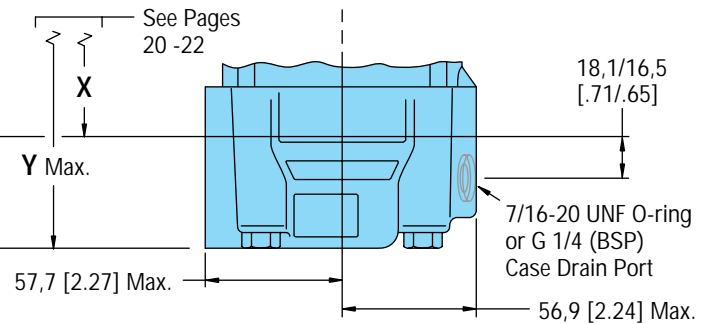
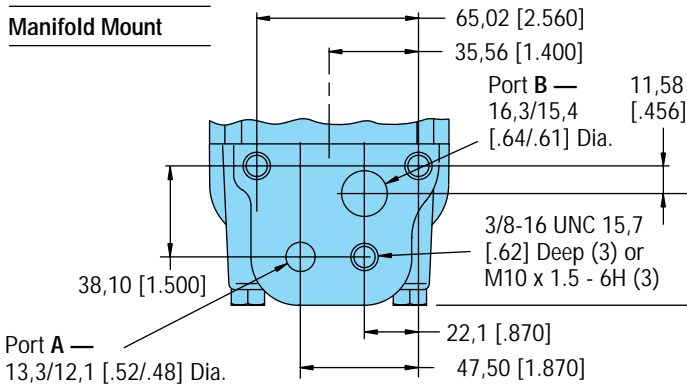

**7/8-14 O-ring  
End Ports (2)**

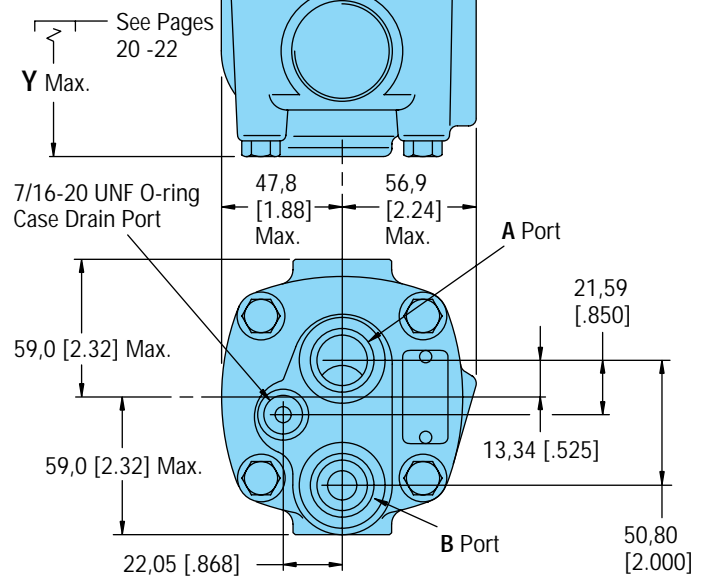

**1-1/16-12  
O-ring Ports (2)  
Positioned  
180° Apart**

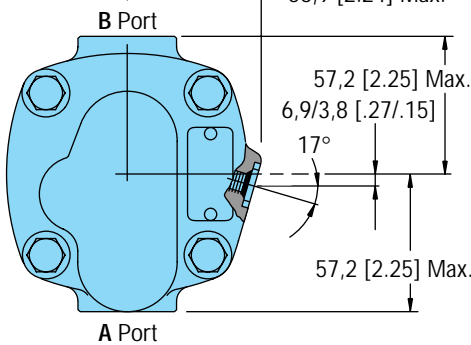

# Dimensions — Ports

## 2000 Series with Shuttle

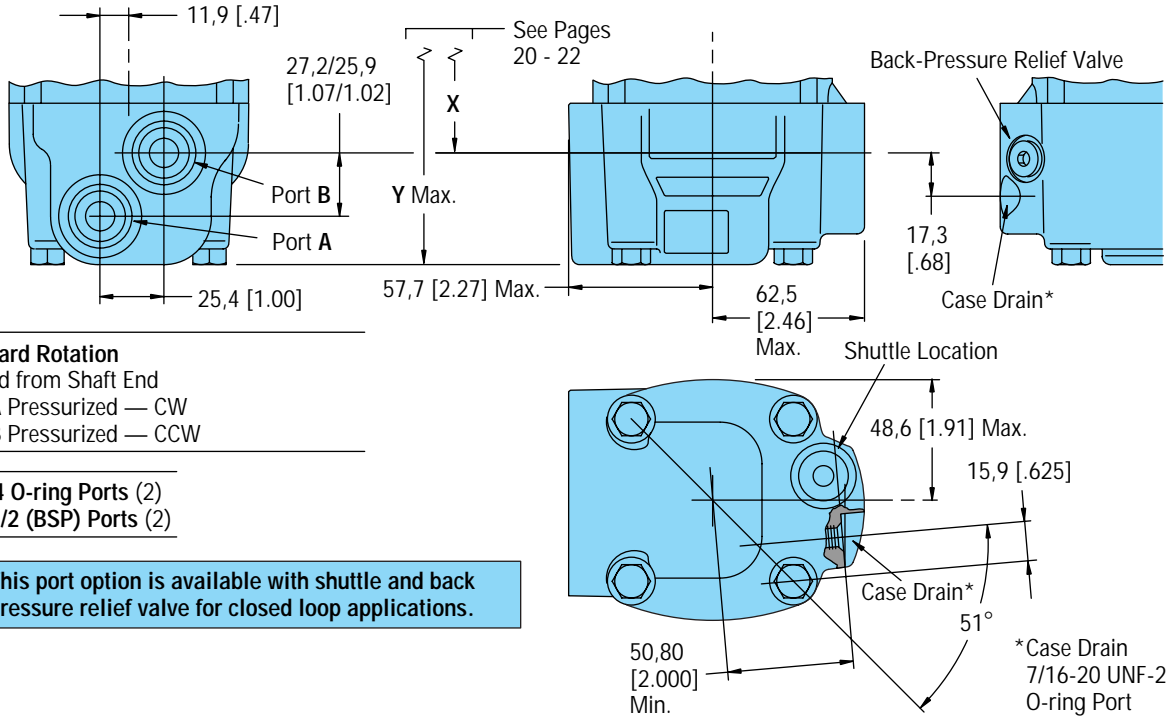

**Standard Rotation**  
 Viewed from Shaft End  
 Port A Pressurized — CW  
 Port B Pressurized — CCW

7/8-14 O-ring Ports (2)  
 or G 1/2 (BSP) Ports (2)

This port option is available with shuttle and back pressure relief valve for closed loop applications.

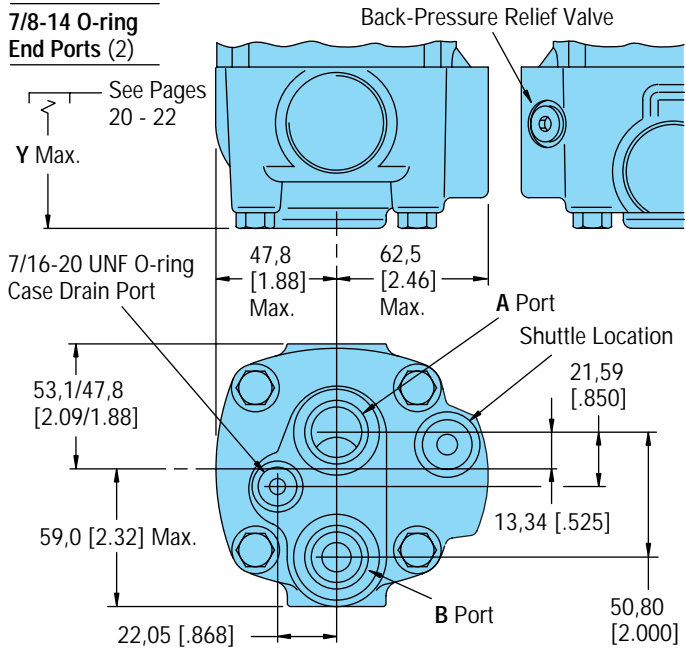

This port option is available with shuttle and back pressure relief valve for closed loop applications.

# Product Numbers 2000 Series

## Product Numbers—2000 Series

Use digit prefix —104-, 105-, or 106- plus four digit number from charts for complete product number—Example 106-1043.

**Orders will not be accepted without three digit prefix.**

Mounting	Shaft	Ports	Displacement cm <sup>3</sup> /r [ in <sup>3</sup> /r ] and Product Number								
			80 [ 4.9]	100 [ 6.2]	130 [ 8.0]	160 [ 9.6]	195 [11.9]	245 [14.9]	305 [18.7]	395 [24.0]	490 [29.8]
2 Bolt SAE A Flange	1 inch Straight	7/8-14 O-ring Staggered	104-1001	-1002	-1003	-1004	-1005	-1006	-1007	-1143	—
		1-1/16—12 O-ring 180° Apart	104-1037	-1038	-1039	-1040	-1041	-1042	-1043	-1044	—
	1-1/4 Inch Straight	7/8-14 O-ring Staggered	104-1022	-1023	-1024	-1025	-1026	-1027	-1028	-1228	-1420
		1-1/16—12 O-ring 180° Apart	104-1061	-1062	-1063	-1064	-1065	-1066	-1067	-1068	-1421
	1-1/4 Inch 14 T Splined	7/8-14 O-ring Staggered	104-1029	-1030	-1031	-1032	-1033	-1034	-1035	-1229	-1422
		1-1/16—12 O-ring 180° Apart	104-1087	-1088	-1089	-1090	-1091	-1092	-1093	-1094	-1423
2 Bolt SAE B Flange	1-1/4 Inch Straight	7/8-14 O-ring Staggered	104-1200	-1201	-1202	-1203	-1204	-1205	-1206	-1207	—
	1-1/4 Inch Involute SAE C Splined	7/8-14 O-ring Staggered	104-1208	-1209	-1210	-1211	-1212	-1213	-1214	-1215	—
	1 Inch SAE 6B Splined	7/8-14 O-ring Staggered	104-1193	-1194	-1195	-1196	-1197	-1198	-1199	—	—
	7/8 Inch SAE B Splined	7/8-14 O-ring Staggered	104-1216	-1217	-1218	-1219	-1220	—	—	—	—
Standard with 4 Bolt Square Flange	32 mm Straight	G 1/2 (BSP)	104-1384	-1385	-1386	-1387	-1388	-1389	-1390	-1391	—
	1-1/4 Inch 14 T Splined	G 1/2 (BSP)	104-1376	-1377	-1378	-1379	-1380	-1381	-1382	-1383	—
Wheel Motor	1-1/4 Inch Straight	7/8-14 O-ring Staggered	105- —	—	—	—	—	—	—	—	-1148
		1-1/16—12 O-ring 180° Apart	105- —	—	—	—	—	—	—	—	-1149
	32 mm Straight	G 1/2 (BSP)	105-1134	-1135	-1136	-1137	-1138	-1139	-1140	-1141	—
	1-1/4 Inch Tapered	7/8-14 O-ring Staggered	105-1001	-1002	-1003	-1004	-1005	-1006	-1007	-1060	-1152
		1-1/16—12 O-ring 180° Apart	105-1071	-1072	-1073	-1074	-1075	-1076	-1077	-1078	—
	1-1/4 Inch 14 T Splined	7/8-14 O-ring Staggered	105-1029	-1030	-1031	-1032	-1033	-1034	-1035	-1096	—
1-1/16—12 O-ring 180° Apart		105-1079	-1080	-1081	-1082	-1083	-1084	-1085	-1086	—	
Bearingless		7/8-14 O-ring Staggered	106-1008	-1009	-1010	-1011	-1012	-1013	-1014	-1015	-1047
		G 1/2 (BSP)	106-1038	-1039	-1040	-1041	-1042	-1043	-1044	-1045	—

106-1043

## Product Numbers—2000 Series Motors with Corrosion Protection

Mounting	Shaft	Ports	Displacement cm <sup>3</sup> /r [ in <sup>3</sup> /r ] and Product Number								
			80 [ 4.9]	100 [ 6.2]	130 [ 8.0]	160 [ 9.6]	195 [11.9]	245 [14.9]	305 [18.7]	395 [24.0]	490 [29.8]
2 Bolt SAE A Flange	1 inch Straight	7/8-14 O-ring Staggered	104-1528	-1529	-1530	-1531	-1532	-1533	-1534	-1519	-1535
	1-1/4 Inch Straight	7/8-14 O-ring Staggered	104-1516	-1536	-1537	-1538	-1539	-1452	-1479	-1509	-1489

For 2000 Series Motors with a configuration *Not Shown* in the charts above: Use model code number system on page 30 to specify product in detail.

## Disk Valve Hydraulic Motors

# Model Code for 2000 Series Motors

The following 14-digit coding system has been developed to identify all of the configuration options for the 2000 Series motor. Use this model code to specify a motor with the desired features. All 14-digits of the code must be present when ordering. You may want to photocopy the matrix below to ensure that each number is entered in the correct box.

### Model Code — 2000 Series Disc Valve Motor

1	2	3	4	5	6	7	8	9	10	11	12	13	14	15	16	17	18	19	20	21	22	23	24	
M	0	2																						

#### Position 1 **Product Series**

**M** ..... Motor

#### Position 2, 3 **2000 Series**

**02** ..... 2000 Series

#### Position 4, 5 **Displacement cm<sup>3</sup>/r [in<sup>3</sup>/r]**

<b>05</b> ..... 80 [ 4.9]	<b>15</b> ..... 245 [14.9]
<b>06</b> ..... 100 [ 6.2]	<b>19</b> ..... 305 [18.7]
<b>08</b> ..... 130 [ 8.0]	<b>24</b> ..... 395 [24.0]
<b>10</b> ..... 160 [ 9.6]	<b>30</b> ..... 490 [29.8]
<b>12</b> ..... 195 [11.9]	

#### Position 6, 7 **Mounting Flange**

**AD** ..... 4 Bolt (Bearingless) 101,6 [4.00] Pilot Dia. and 13,59 [.535] Dia. Mounting Holes on 127,0 [5.00] Dia. B.C.

**AC** ..... 2 Bolt SAE A (Std.) 82,5 [3.25] Pilot Dia. and 13,59 [.535] Dia. Mtg. Holes on 106,4 [4.19] Dia. B.C.

**AB** ..... 4 Bolt (Wheel) 108,0 [4.25] Pilot Dia. and 13,59 [.535] Dia. Mounting Holes on 147,6 [5.81] Dia. B.C.

**AH** ..... 4 Bolt (Standard) 82,5 [3.25] Pilot Dia. and 14,59 [.535] Dia. Mounting Holes on 106,4 [4.19] Dia. B.C.

**AJ** ..... 4 Bolt Magneto (Std.) 82,5 [3.25] Pilot Dia. and 13,59 [.535] Dia. Mtg. Holes on 106,4 [4.19] Dia. B.C.

**AF** ..... 2 Bolt SAE B (Std.) 101,6 [4.00] Pilot Dia. and 14,35 [.565] Dia. Mtg. Holes on 146,0 [5.75] Dia. B.C.

**AP** ..... 4 Bolt (wheel compatible for HAYES BRAKE) 107,9 [4.25] Pilot Dia. and 13,59 [.535] Dia. Mounting Holes on 147,6 [5.81] Dia. B.C. with Turned Down Housing to 88,9 [3.50] Dia.

#### Position 8, 9 **Output Shaft**

**00** ..... Bearingless

**01** ..... 1 inch Dia. Straight with Woodruff Key, 1/4-20 Threaded Hole and 38,4 [1.51] Max. Coupling Length

**02** ..... 1-1/4 inch Dia. Straight with Straight Key, 3/8-16 Threaded Hole and 47,3 [1.86] Max. Coupling Length

**23** ..... 32 mm dia. Straight with Straight Key, M8 x 1,25 -6H Threaded Hole and 56,4 [2.22] Max. Coupling Length

**04** ..... 1-1/4 inch Dia. Splined 14 T, 3/8-16 Threaded Hole and 33,0 [1.30] Min. Full Spline Length and 45,5 [1.79] Max. Coupling Length

**03** ..... 1-1/4 inch Dia. Tapered with Straight Key and Nut

**05** ..... 1 inch SAE 6B Splined 6T, 1/4-20 Threaded Hole and 22,8 [.90] Min. Full Spline Length and 28,8 [1.13] Max. Coupling Length

**07** ..... 7/8 inch Dia. Splined 13T, 15,2 [.60] Min. Full Spline Length and 30,8 [1.21] Max. Coupling Length

**24** ..... 1-1/4 inch Dia. Straight with Straight Key, 3/8-16 Threaded Hole and Corrosion Resistant (seal area to shaft end)

**25** ..... 1-1/4 inch Dia. Tapered with Straight Key and Nut, Corrosion Resistant (under seal area only)

**26** ..... 25 mm Dia. Straight with Straight Key, M8 x 1,25 -6H Threaded Hole and 38,4 [1.51] Max. Coupling Length

#### Position 10, 11 **Port Type**

**AA** ..... 7/8-14 UNF -2B SAE O-ring (Staggered)

**AG** ..... G 1/2 BSP Straight Thread ports (Staggered)

**AB** ..... Manifold Mount with 3/8-16 UNC Mounting Threads (3)

**AE** ..... Manifold Mount with M10 x 1,5 -6H Mounting Threads (3)

**AD** ..... 7/8-14 UNF -2B SAE O-ring (End Ports)

**AF** ..... 1-1/16 - 12 UN-2B O-ring ports (Positioned 180° Apart)

#### Position 12, 13 **Case Flow**

(Shuttles available with port code AA or AD only)

**01** ..... 7/16-20 UNF -2B SAE O-ring (Case Drain)

**02** ..... G 1/4 (BSP) straight thread port (Case Drain)

**04** ..... Shuttle Valve with 7/16-20 UNF -2B SAE O-ring (Case Drain)

**05** ..... Shuttle Valve with G 1/4 (BSP) straight thread port (Case Drain)

#### Position 14 **Low Pressure Relief**

(LPR available with a combination of case flow code 04 or 05 and port code AA or AD only)

**0** ..... None

**A** ..... Set @ 4,5 bar [65 psi]

**B** ..... Set @ 15,2 bar [220 psi]

**C** ..... Set @ 20,7 bar [300 psi]

#### Position 15, 16 **Valve Option**

**00** ..... None

#### Position 17, 18 **Accessories**

**00** ..... None

**AA** ..... Seal Guard

**AB** ..... Speed Sensor (Std. With Weatherpack shroud connector)

**AH** ..... Speed Sensor (Std. With M12 connector)

**AL** ..... Quadrature Speed Sensor Version 2 with M12

#### Position 19, 20 **Special Features (Hardware)**

**00** ..... None

**01** ..... Viton Seals

**10** ..... Viton Shaft Seal

#### Position 21 **Special Features (Assembly)**

**0** ..... None

**A** ..... Flange Rotated 90°

**B** ..... Reverse Rotation

#### Position 22 **Paint/Special Packaging**

**0** ..... No Paint

**A** ..... Painted Low Gloss Black

**B** ..... Corrosion Protected

#### Position 23 **Eaton Assigned Code when Applicable**

**0** ..... Assigned Code

#### Position 24 **Eaton Assigned Design Code**

**0** ..... Assigned Design Code

## Two Speed Motor — 2000 Series

The Eaton 2000 Series motors are available with an integral two speed feature that changes the displacement in a ratio of 1 to 2 and shifts the motor from a low speed high torque (LSHT) mode to a high speed low torque (HSLT) mode. The open center selector valve shifts the speed mode from low to high speed when pilot pressure of 6.9  $\Delta$  Bar [100  $\Delta$  PSI] minimum is applied to the pilot port (6.9 Bar [100 PSI] higher than case pressure). In the high speed mode torque values are approximately one half with twice the speed of the conventional 2000 Series single speed motors.

An external two position three way valve is required for shifting the pilot pressure port between signal pressure (HSLT) and low pressure (LSHT)

Two speed motors are available with a return line closed center shuttle for closed circuit applications.

Low speed high torque mode is the normal position of the speed selector valve. When a differential pressure is supplied to the pilot port and 6.9 Bar [100 PSI] is reached, the selector valve overcomes the return spring force and the spool shifts to the high speed mode. The oil in the opposite side of the spool is drained internally. Pressure between the pilot supply and case drain or return line (depending on open or closed circuit system) must be maintained to keep the motor in the high speed mode.

When pilot pressure is removed from the pilot port the pressure in the pilot end of the spool valve is relieved and drained back through this three way valve, the spring force returns the spool valve to LSHT position.

Pilot pressure may come from any source that will provide uninterrupted pressure during the high speed mode operation. Pilot pressure 6.9  $\Delta$  Bar [100  $\Delta$  PSI] minimum, up to the full operating pressure of the motor.

In normal LSHT operation the Char-Lynn two speed motor will function with equal shaft output in either direction (CW or CCW), the same as the single speed Char-Lynn disc valve motors.

However, to prevent cavitation in the HSLT mode, the preferred direction of shaft rotation is counter clockwise (port B pressurized). This unique disc valve is not symmetrical in porting the fluid for the HSLT mode. Consequently, when the pressure is reversed for HSLT CW rotation, cavitation can occur. Installing a restriction (14 - 34 Bar [200 - 500 PSI]) in the hydraulic line that connects port B will prevent cavitation (see page 32).

If you are operating in a critical area and a restriction in the hydraulic line causes concern, these two speed motors can be ordered timed with CW preferred HSLT shaft rotation. Hence, with this option port B will have to be pressurized for CW preferred HSLT shaft rotation. The restriction recommended for the line connecting port B remains unchanged. Finally in closed circuit applications a hydraulic line restriction is not required. Instead, the charge pump can be used to supply and maintain a minimum pressure of 14 Bar [200 PSI].

**Note:** Be certain in closed loop applications that the charge pump when used for back pressure on the B port, has sufficient displacement to maintain charge pressure especially in dynamic braking or overrunning load conditions.

**Important!** Due to potential problems in maintaining charge pump pressure at port B for uninterrupted back pressure during dynamic braking, Eaton does not recommend the two speed motor where overrunning conditions may exist.

## Performance Data Two Speed Motor — 2000 Series

In the high speed mode torque values are approximately one half with twice the speed of the conventional 2000 Series single speed motors. In the low speed mode torque and speed values are the same as the conventional 2000 Series motors (see Performance Data on pages 15-19). For Two Speed Motor Specifications, Dimensions, and Product Numbers see pages 33 through 35.

# Two Speed Motor — 2000 Series

Pump Pressure and Return, and  
Shaft Rotation Directional Control Valve

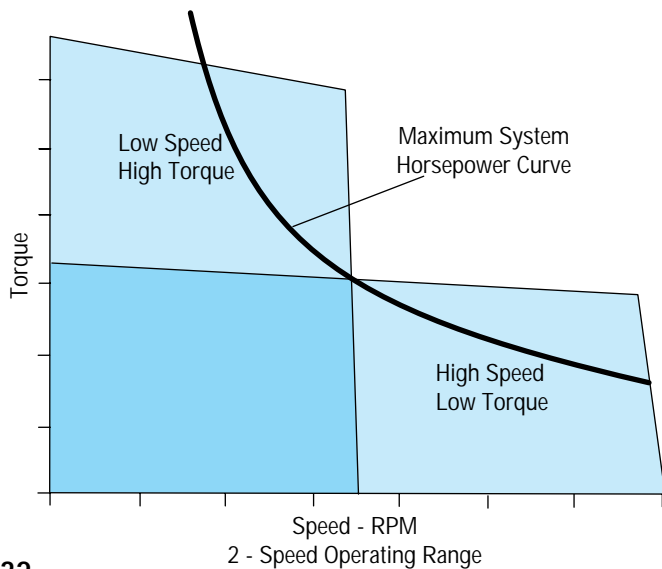
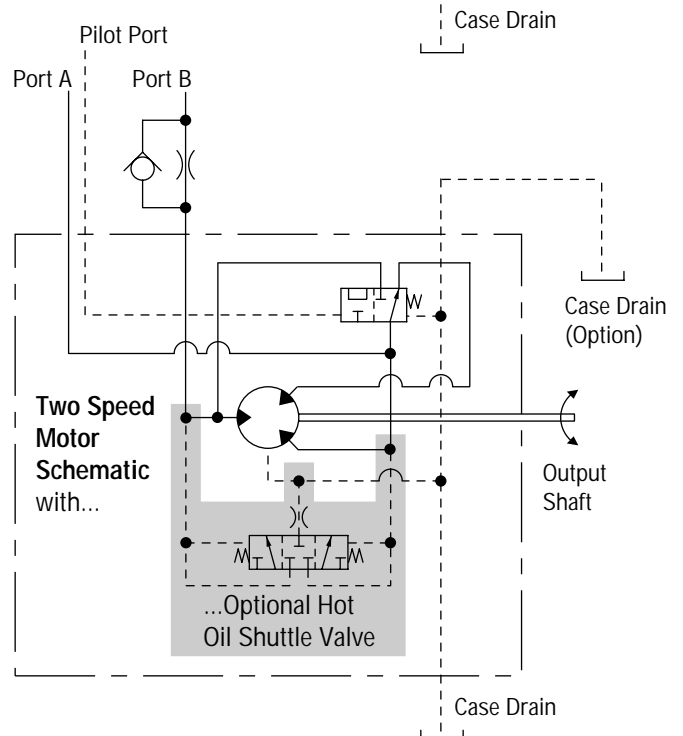
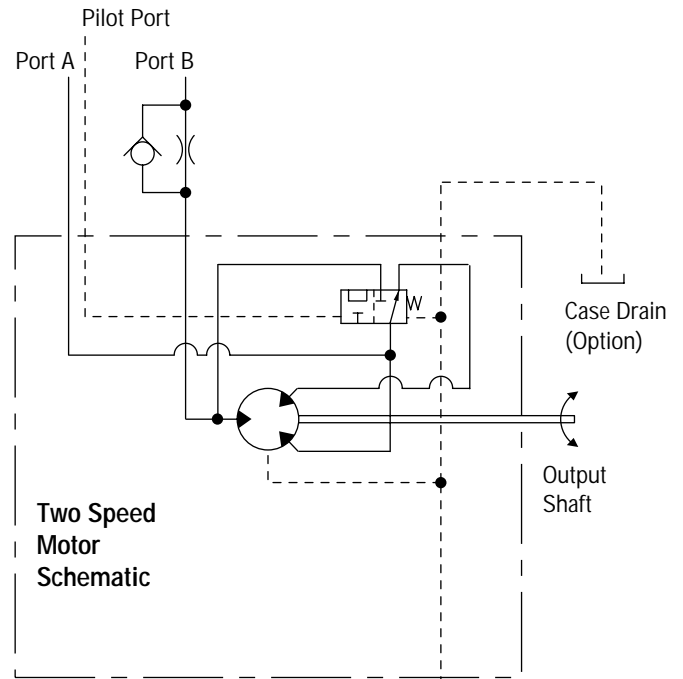
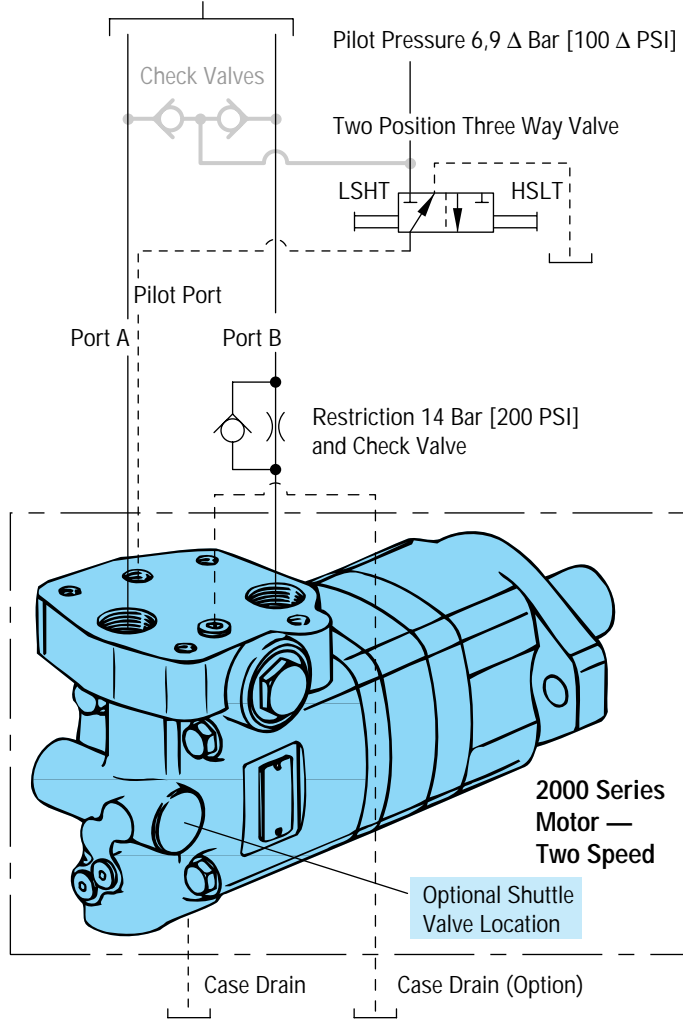



# Specifications

## Two Speed Motor — 2000 Series

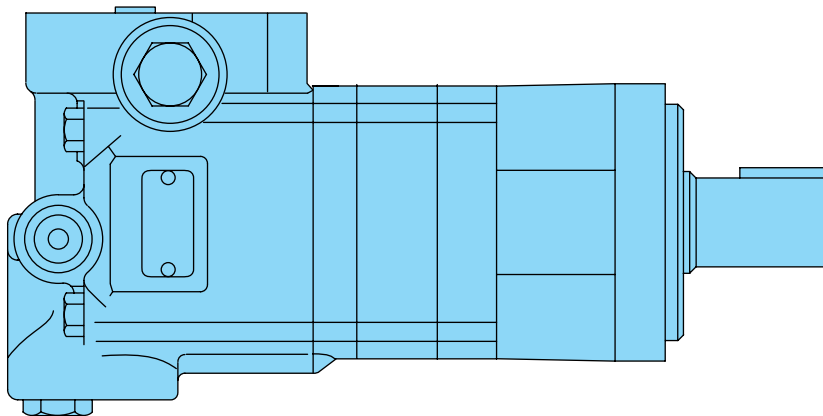

### Specification Data—2000 Series Two Speed

Displ. cm <sup>3</sup> /r. [in <sup>3</sup> /r]	<b>High Speed Mode</b>	40 [ 2.45]	50 [ 3.1]	65 [ 4.0]	80 [ 4.8]	95 [ 5.95]	120 [ 7.45]	155 [ 9.35]	195 [12.0]	245 [15.0]
	<b>Low Speed Mode</b>	80 [ 4.9]	100 [ 6.2]	130 [ 8.0]	160 [ 9.6]	195 [11.9]	245 [14.9]	305 [18.7]	395 [24.0]	490 [29.8]
Max. Speed (RPM) @ Continuous Flow	<b>High Speed Mode</b>	1000	1000	990	860	700	560	450	350	230
	<b>Low Speed Mode</b>	500	500	495	430	350	280	225	175	115
Flow LPM [GPM]	<b>High Speed Mode</b>	45 [12]	55 [15]	70 [19]	75 [20]	75 [20]	75 [20]	75 [20]	75 [20]	75 [20]
	<b>Low Speed Mode</b>	45 [12]	55 [15]	70 [19]	75 [20]	75 [20]	75 [20]	75 [20]	75 [20]	75 [20]
Torque Nm [lb-in] ★ 1-1/4 Inch or 32 mm Dia. Shaft	<b>High Speed Mode</b>	Continuous 100 [880]	125 [1115]	165 [1450]	195 [1725]	240 [2150]	300 [2675]	380 [3350]	365 [3225]	448 [3970]
	Intermittent	145 [1300]	185 [1660]	240 [2150]	240 [2150]	300 [2650]	375 [3330]	440 [3900]	445 [3940]	486 [4300]
Torque Nm [lb-in] ★ 1-1/4 Inch or 32 mm Dia. Shaft	<b>Low Speed Mode</b>	Continuous 235 [2065]	295 [2630]	385 [3420]	455 [4040]	540 [4780]	660 [5850]	760 [6750]	770 [6840]	845 [7470]
	Intermittent	345 [3040]	445 [3950]	560 [4970]	570 [5040]	665 [5890]	820 [7250]	885 [7820]	925 [8170]	930 [8225]
Pressure ★ Δ Bar [Δ PSI]	1-1/4 Inch or 32 mm Dia. Shaft	Continuous	205 [3000]	205 [3000]	205 [3000]	205 [3000]	205 [3000]	205 [3000]	155 [2250]	120 [1750]
	Intermittent	310 [4500]	310 [4500]	310 [4500]	260 [3750]	260 [3750]	260 [3750]	240 [3500]	190 [2750]	140 [2000]

Maximum Case Pressure - without Case Drain \* — 140 Bar [2000 PSI]

#### High Speed Mode (Reduced Motor Displacement)

#### Low Speed Mode (Full Motor Displacement)

Maximum torque and flow must not occur simultaneously. For permissible continuous and intermittent operating combinations of pressure and flow refer to performance data on pages 15-19 (LSHT only).

★ **Maximum torque for 1 inch shaft** — 395 Nm [3500 lb-in] Continuous and 485 Nm [4300 lb-in] intermittent.

\* For back pressure over 140 Bar [2000 PSI] use an external case drain. Install case drain lines so that the motor case remains filled at all times.

**Maximum inlet pressure** — 310 Bar [4500 PSI]. Do not exceed Δ pressure rating (see chart above).

\* **Maximum return pressure** — 310 Bar [4500 PSI]. Do not exceed Δ pressure rating (see chart above).

Δ Bar [Δ PSI] — True pressure difference between inlet port and outlet port.

**Continuous Rating** — Motor may be run continuously at these ratings.

**Intermittent Operation** — 10% of every minute.

**Recommended Fluids** — Premium quality, anti-wear type hydraulic oil with a viscosity of not less than 70 SUS at operating temperature (see page 81).

**Recommended Maximum System Operating Temp.** — Is 82° C [180° F]

**Recommended Filtration** — per ISO Cleanliness Code, level 18/13

To assure best motor life, run motor for approximately one hour at 30% of rated pressure before application to full load. Be sure motor is filled with fluid prior to any load applications.

# Dimensions — Two Speed Standard, Wheel, and Bearingless

**Standard Rotation**  
Viewed from Shaft or Drive End  
Port A Pressurized — CW  
Port B Pressurized — CCW

## Two Speed Standard Motor

Displ. cm <sup>3</sup> /r [in <sup>3</sup> /r]	80 [ 4.9]	100 [ 6.2]	130 [ 8.0]	160 [ 9.6]	195 [11.9]	245 [14.9]	305 [18.7]	395 [24.0]	490 [29.8]
Dim. X mm [inch]	137,4 [ 5.41]	142,0 [ 5.59]	148,5 [ 5.85]	148,5 [ 5.85]	155,2 [ 6.11]	164,2 [ 6.47]	175,7 [ 6.92]	191,5 [ 7.54]	209,0 [ 8.23]
Dim. Y mm [inch]	231,6 [ 9.12]	236,5 [ 9.31]	242,9 [ 9.56]	242,9 [ 9.56]	249,4 [ 9.82]	258,6 [10.18]	270,1 [10.63]	286,1 [11.26]	303,3 [11.94]

## Two Speed Wheel Motor

Dim. X mm [inch]	97,2 [ 3.83]	101,8 [ 4.01]	108,3 [ 4.27]	108,3 [ 4.27]	115,0 [ 4.53]	124,2 [ 4.89]	135,5 [ 5.34]	151,4 [ 5.96]	168,9 [ 6.65]
Dim. Y mm [inch]	191,5 [ 7.54]	196,4 [ 7.73]	202,7 [ 7.98]	202,7 [ 7.98]	209,3 [ 8.24]	218,5 [ 8.60]	229,9 [ 9.05]	245,9 [ 9.68]	263,1 [10.36]

## Two Speed Bearingless Motor

Dim. X mm [inch]	79,3 [ 3.13]	83,8 [ 3.30]	90,3 [ 3.56]	90,3 [ 3.56]	97,0 [ 3.82]	106,2 [ 4.18]	117,8 [ 4.64]	133,6 [ 5.26]	150,9 [ 5.94]
Dim. Y mm [inch]	174,0 [ 6.85]	178,9 [ 7.04]	185,2 [ 7.29]	185,2 [ 7.29]	191,8 [ 7.55]	201,0 [ 7.91]	212,4 [ 8.36]	228,4 [ 8.99]	245,6 [ 9.67]

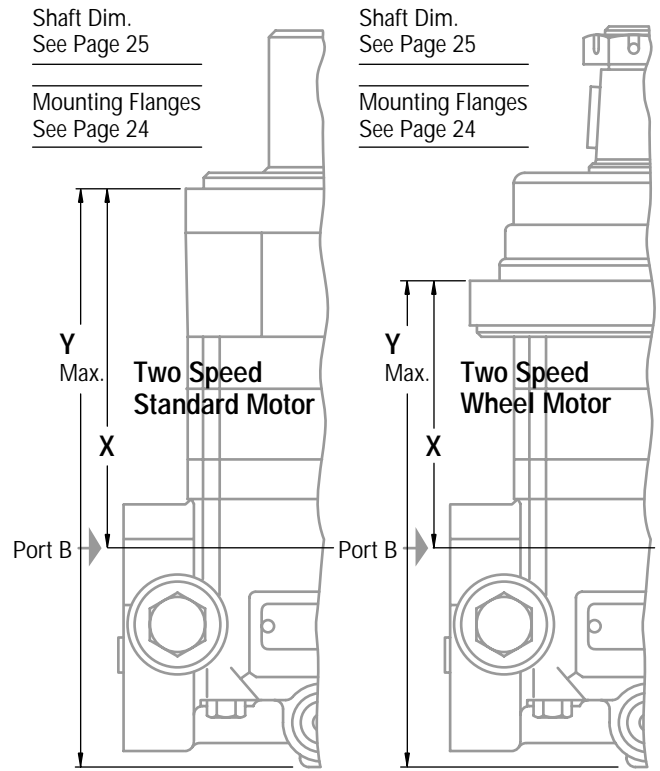

7/16-20 UNF-2B O-ring Port — Pilot Control  
Pilot Port Pressurized 6,9 Δ Bar [100 Δ PSI]  
High Speed Low Torque (HSLT)  
Pilot Port Depressurized (Tank)  
Low Speed High Torque (LSHT)

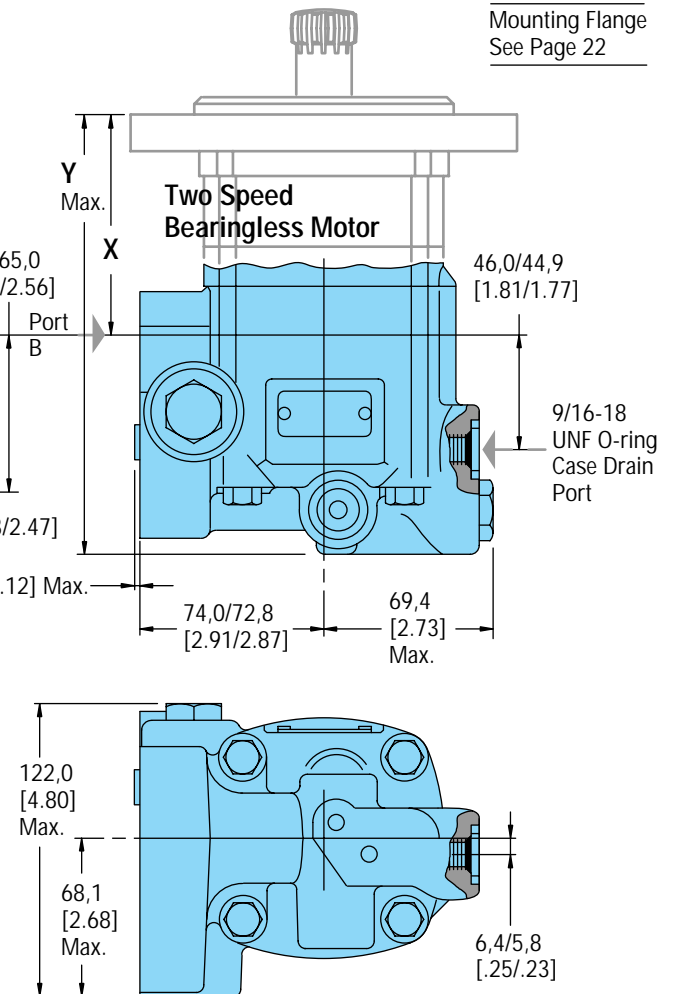
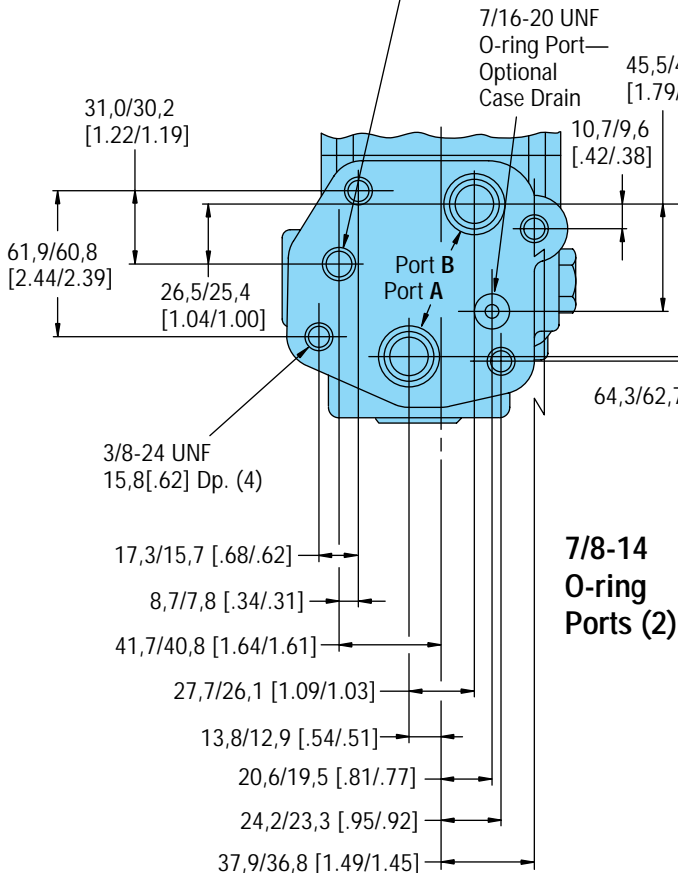

# Product Numbers — Two Speed 2000 Series

## Product Numbers—2000 Series Motors — Two Speed

Use digit prefix —**104-**, **105-**, or **106-** plus four digit number from charts for complete product number—Example **106-2007**.  
Orders will not be accepted without three digit prefix.

Mounting	Shaft	Ports	Displ. cm <sup>3</sup> /r [in <sup>3</sup> /r] Product Number								
			80 [ 4.9]	100 [ 6.2]	130 [ 8.0]	160 [ 9.6]	195 [11.9]	245 [14.9]	305 [18.7]	395 [24.0]	490 [29.8]
2 Bolt SAE A Flange	1 inch Straight	7/8-14 O-ring Staggered	<b>104-2001</b>	-2002	-2003	-2004	-2005	-2006	-2007	-2008	—
	1-1/4 Inch Straight	7/8-14 O-ring Staggered	<b>104-2009</b>	-2010	-2011	-2012	-2013	-2014	-2015	-2016	—
	1-1/4 Inch 14 T Splined	7/8-14 O-ring Staggered	<b>104-2017</b>	-2018	-2019	-2020	-2021	-2022	-2023	-2024	—
Wheel Motor	1-1/4 Inch Tapered	7/8-14 O-ring Staggered	<b>105-2001</b>	-2002	-2003	-2004	-2005	-2006	-2007	-2008	—
	1-1/4 Inch 14 T Splined	7/8-14 O-ring Staggered	<b>105-2009</b>	-2010	-2011	-2012	-2013	-2014	-2015	-2016	—
Bearingless		7/8-14 O-ring Staggered	<b>106-2001</b>	-2002	-2003	-2004	-2005	-2006	-2007	-2008	—

106-2007

2000 Series Motors with a configuration *Not Shown* in the charts above: Contact your Eaton Representative.

# Hayes M15WM Brake System 2000 Series Wheel Motors

Hayes Industrial Brakes, Inc. supplies its Model M15WM mechanical parking/service brake for use with 2000 Series wheel motors on commercial turf and specialty-vehicle applications. Basic packages available are:

- M15WM for 203,2 [8.0] wheels (152,4 [6.0] rotor diameter)
- M15WM for 254 [10.0] wheels (209,6 [8.25] rotor diameter)

## Features

- Up to 1450 lb. of clamping force available
- Simple single-piece caliper bridge design
- Fewer moving parts
- Comprehensive braking system design includes:
  - Aluminum caliper
  - Ductile cast iron bracket
  - Ductile cast iron hub/disc
- Several shaft sizes and hub mounting hole options available.

**Note:** Brake systems must be purchased directly from Hayes Industrial Brake. Eaton does not sell the brake nor does it install on motors. For more information, contact:

Hayes Industrial Brake, Inc.  
5800 West Donges Bay Road  
Mequon, WI 57092  
Phone: (262) 242-4300; Fax: (262) 242-0524

## Dimensions — Mounting

### 8-Inch Wheel 305 N-m (2700 lb-in) Max. Torque

Requires special 2K mounting code "P".

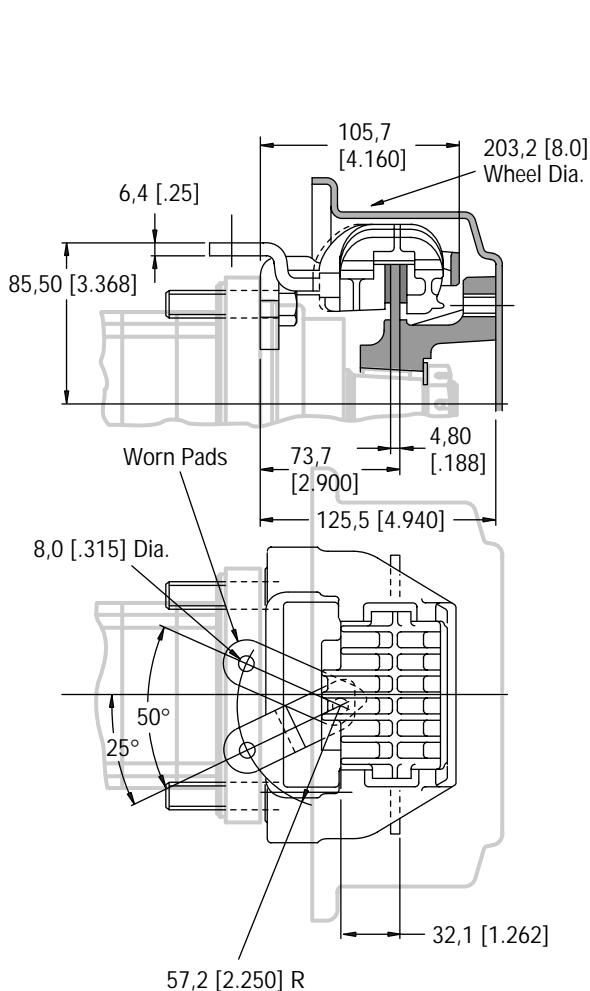

### 10-Inch Wheel 429,4 N-m (3800 lb-in) Max. Torque

Compatible with standard 4-bolt wheel configuration

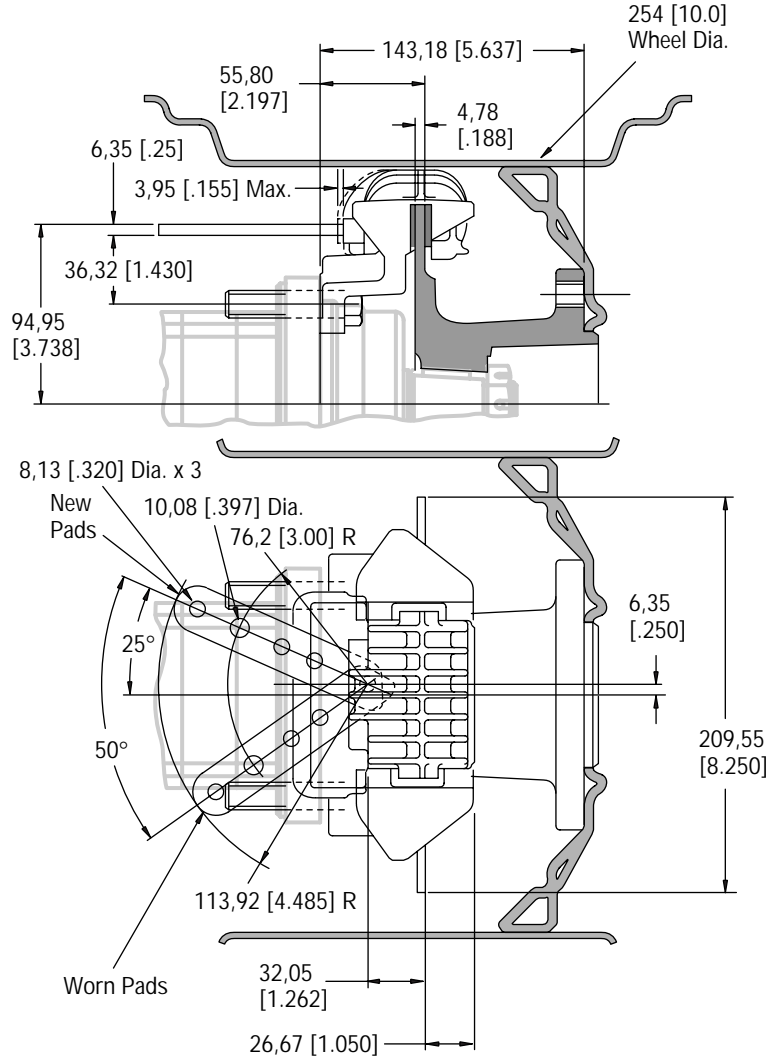

# Specifications

## 4000 Series

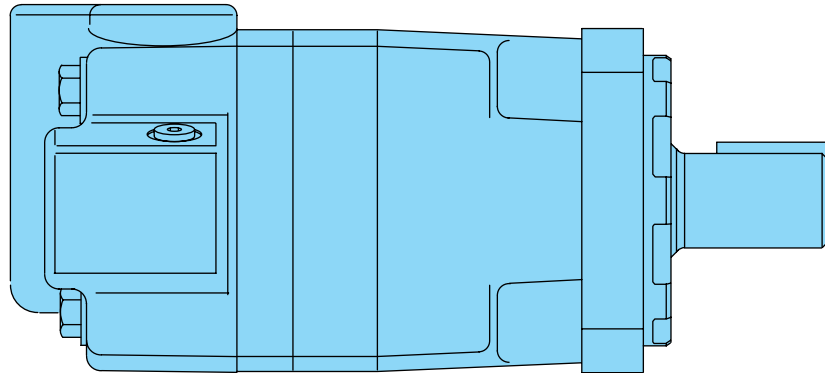

### Specification Data—4000 Series

		110	130	160	205	245	310	395	495	625	
Displ. cm <sup>3</sup> /r	[in <sup>3</sup> /r]	110 [ 6.7]	130 [ 7.9]	160 [ 9.9]	205 [12.5]	245 [15.0]	310 [19.0]	395 [24.0]	495 [30.0]	625 [38.0]	
Max. Speed (RPM) @ ..... Flow	Continuous	697	722	582	459	383	303	239	191	151	
	Intermittent	868	862	693	546	532	422	376	305	241	
Flow LPM [GPM]	Continuous	75 [20]	95 [25]	95 [25]	95 [25]	95 [25]	95 [25]	95 [25]	95 [25]	95 [25]	
	Intermittent	95 [25]	115 [30]	115 [30]	115 [30]	130 [35]	130 [35]	150 [40]	150 [40]	150 [40]	
Torque Nm [lb-in]	★ 1-5/8 Inch Dia. Tapered Shaft	Continuous	320 [2850]	375 [3330]	485 [4290]	600 [5300]	705 [6240]	850 [7530]	930 [ 8240]	945 [ 8375]	970 [ 8605]
		Intermittent	470 [4160]	560 [4940]	705 [6240]	800 [7100]	845 [7470]	1065 [9420]	1185 [10470]	1170 [10350]	1180 [10450]
Pressure Δ Bar [Δ PSI]	★ 1-5/8 Inch Dia. Tapered Shaft	Continuous	205 [3000]	205 [3000]	205 [3000]	205 [3000]	205 [3000]	205 [3000]	190 [2750]	140 [2000]	115 [1700]
		Intermittent	310 [4500]	310 [4500]	310 [4500]	310 [4500]	260 [3750]	260 [3750]	240 [3500]	170 [2500]	140 [2000]
		Peak	310 [4500]	310 [4500]	310 [4500]	310 [4500]	310 [4500]	310 [4500]	295 [4250]	230 [3300]	180 [2600]

Maximum Case Pressure - without Case Drain \* — 100 Bar [1500 PSI]

**A simultaneous maximum torque and maximum speed NOT recommended.** For permissible continuous and intermittent operating combinations of pressure and flow refer to performance data on pages 38 - 41.

★ **Maximum torque for 1-1/4 inch shaft** — 770 Nm [6800 lb-in] Continuous and 960 Nm [8500 lb-in] intermittent.

\* For back pressure over 105 Bar [1500 PSI] use an external case drain. Install case drain lines so that the motor case remains filled at all times.

**Maximum inlet pressure** — 310 Bar [4500 PSI]. Do not exceed Δ pressure rating (see chart above).

\* **Maximum return pressure** — 310 Bar [4500 PSI]. Do not exceed Δ pressure rating (see chart above).

**Δ Bar [Δ PSI]** — True pressure difference between inlet port and outlet port.

**Continuous Rating** — Motor may be run continuously at these ratings.

**Intermittent Operation** — 10% of every minute.

**Peak Operation** — 1% of every minute.

**Recommended Fluids** — Premium quality, anti-wear type hydraulic oil with a viscosity of not less than 70 SUS at operating temperature (see page 81).

**Recommended Maximum System Operating Temp.** — Is 82° C [180° F]

**Recommended Filtration** — per ISO Cleanliness Code, level 18/13

To assure best motor life, run motor for approximately one hour at 30% of rated pressure before application to full load. Be sure motor is filled with fluid prior to any load applications.





395 cm<sup>3</sup>/r [24.0 in<sup>3</sup>/r]  
 Δ Pressure Bar [PSI]

# Performance Data 4000 Series

	[250] 15	[500] 35	[750] 50	[1000] 70	[1250] 85	[1500] 105	[1750] 120	[2000] 140	[2250] 155	[2500] 170	[2750] 190	[3000] 205	[3250] 225	[3500] 240
[.5] <b>1.9</b>	[700] 80 4	[1340] 150 2												
[1] <b>3.8</b>	[750] 85 9	[1430] 160 9	[2110] 240 8	[2770] 315 8	[3460] 390 8	[4170] 470 7	[4890] 550 7	[5610] 635 7	[6310] 715 5	[7010] 790 4	[7700] 870 2			
[2] <b>7.5</b>	[800] 90 18	[1500] 170 18	[2290] 260 17	[3030] 340 16	[3850] 435 16	[4620] 520 15	[5310] 600 15	[6000] 680 14	[6750] 765 13	[7490] 845 13	[8240] 930 12	[8990] 1015 11	[9730] 1100 10	[10470] 1185 8
[4] <b>15</b>	[860] 95 38	[1630] 185 38	[2470] 280 37	[3310] 375 36	[4120] 465 36	[4900] 555 35	[5640] 635 35	[6390] 720 34	[7190] 810 34	[7890] 890 33	[8780] 990 32			
[6] <b>23</b>	[860] 95 57	[1690] 190 57	[2540] 285 56	[3410] 385 55	[4180] 470 54	[4980] 565 53	[5780] 655 52	[6580] 745 50	[7400] 835 49	[8220] 930 47				
[8] <b>30</b>	[840] 95 76	[1680] 190 76	[2550] 290 75	[3400] 385 74	[4260] 480 73	[5090] 575 72	[5870] 665 70	[6650] 750 68	[7480] 845 66					
[10] <b>38</b>	[800] 90 95	[1680] 190 95	[2550] 290 94	[3400] 385 93	[4260] 480 92	[5100] 575 91	[5920] 670 89	[6730] 760 86	[7560] 855 84					
[12] <b>45</b>	[760] 85 114	[1660] 190 114	[2520] 285 113	[3380] 380 112	[4270] 480 111	[5110] 575 110	[5900] 665 108	[6690] 755 105						
[14] <b>53</b>	[740] 85 133	[1640] 185 133	[2490] 280 132	[3370] 380 131	[4260] 480 130	[5100] 575 129	[5880] 665 127	[6650] 750 124						
[16] <b>61</b>	[710] 80 153	[1620] 185 153	[2460] 280 152	[3350] 380 151	[4240] 480 149	[5080] 575 147	[5840] 660 145							
[18] <b>68</b>	[680] 75 172	[1600] 180 172	[2430] 275 171	[3340] 375 170	[4220] 475 168	[5060] 570 166	[5810] 655 164							
[20] <b>76</b>	[610] 70 192	[1580] 180 191	[2400] 270 190	[3320] 375 189	[4210] 475 187	[5040] 570 185	[5780] 655 183							
[22] <b>83</b>	[570] 65 211	[1490] 170 210	[2340] 265 209	[3220] 365 208	[4160] 470 206	[5010] 565 204	[5740] 650 201							
[25] <b>95</b>	[490] 55 239	[1350] 155 238	[2250] 255 237	[3080] 350 236	[4070] 460 235	[4960] 560 233	[5700] 645 230							
[30] <b>114</b>		[1080] 120 285	[1650] 185 284	[2270] 255 282	[3020] 340 281	[3850] 435 279								
[35] <b>132</b>			[1520] 170 331	[2120] 240 330	[2870] 325 328	[3760] 425 325								
[40] <b>151</b>				[2050] 230 376	[2790] 315 374	[3620] 410 371								

Motors run with high efficiency in all areas designated with a number for torque and speed, however for best motor life select a motor to run with a torque and speed range shown in the light blue area.

[2050]  
230  
376 } Torque [lb-in]  
Nm  
Speed RPM

Continuous  
Intermittent

495 cm<sup>3</sup>/r [30.0 in<sup>3</sup>/r]  
 Δ Pressure Bar [PSI]

	[250] 15	[500] 35	[750] 50	[1000] 70	[1250] 85	[1500] 105	[1750] 120	[2000] 140	[2250] 155	[2500] 170
[.5] <b>1.9</b>	[800] 90 3	[1750] 200 1								
[1] <b>3.8</b>	[880] 100 7	[1875] 210 6	[2875] 325 6	[3825] 430 5	[4775] 540 4	[5720] 645 3	[6670] 755 2	[7600] 860 1		
[2] <b>7.5</b>	[905] 100 18	[1940] 220 17	[2975] 335 17	[3990] 450 16	[5010] 565 15	[6010] 680 12	[7010] 790 11	[8000] 905 10	[8980] 1015 8	
[4] <b>15</b>	[935] 105 30	[2005] 225 29	[3075] 345 28	[4160] 470 27	[5245] 595 26	[6300] 710 23	[7355] 830 21	[8375] 945 19	[9400] 1060 17	[10350] 1170 14
[6] <b>23</b>	[920] 105 45	[2010] 225 44	[3100] 350 43	[4185] 475 42	[5265] 595 40	[6345] 715 37	[7420] 840 35	[8445] 955 32	[9465] 1070 30	
[8] <b>30</b>	[905] 100 61	[2015] 230 60	[3125] 355 59	[4205] 475 57	[5290] 600 55	[6385] 720 52	[7485] 845 49	[8510] 960 46		
[10] <b>38</b>	[880] 100 76	[1995] 225 75	[3095] 350 74	[4205] 475 72	[5295] 600 70	[6390] 720 66	[7480] 845 63	[8525] 960 59		
[12] <b>45</b>	[860] 95 91	[1975] 225 90	[3095] 350 89	[4200] 475 87	[5305] 600 85	[6390] 720 81	[7475] 845 77			
[14] <b>53</b>	[830] 95 106	[1945] 220 105	[3055] 345 104	[4165] 470 102	[5275] 595 100	[6360] 720 96	[7445] 840 92			
[16] <b>61</b>	[805] 90 122	[1910] 215 120	[3020] 340 119	[4130] 465 117	[5245] 595 115	[6330] 715 111	[7420] 840 107			
[18] <b>68</b>	[740] 85 137	[1860] 210 136	[2980] 335 134	[4105] 465 132	[5235] 590 130	[6305] 715 125	[7380] 835 121			
[20] <b>76</b>	[680] 75 153	[1810] 205 152	[2940] 330 150	[4085] 460 147	[5225] 590 145	[6285] 710 140				
[25] <b>95</b>	[570] 65 191	[1665] 190 189	[2800] 315 187	[4005] 455 184	[5210] 590 182	[6135] 695 177				
[30] <b>114</b>		[1520] 170 228	[2645] 300 226	[3765] 425 223	[4885] 550 220	[5985] 675 215				
[35] <b>132</b>			[2400] 270 265	[3510] 395 263						
[40] <b>151</b>			[2155] 245 305	[3260] 370 303						

Performance data is typical at 120 SUS. Actual data may vary slightly from unit to unit in production



# Performance Data 4000 Series

625 cm<sup>3</sup>/r [38.0 in<sup>3</sup>/r]  
Δ Pressure Bar [PSI]

	[250] 15	[500] 35	[750] 50	[1000] 70	[1250] 85	[1500] 105	[1600] 100	[1700] 115	[1800] 125	[2000] 140
[.5] 1.9	[1000] 115 2									
[1] 3.8	[1080] 120 5	[2340] 265 5	[3600] 405 5	[4850] 550 4	[6100] 690 4	[7350] 830 3	[7820] 885 3	[8290] 935 2	[8760] 990 2	
[2] 7.5	[1085] 125 14	[2380] 270 14	[3675] 415 14	[5010] 565 13	[6350] 715 12	[7625] 860 11	[8115] 915 10	[8605] 970 9	[9095] 1030 8	[10075] 1140 7
[4] 15	[1090] 125 23	[2420] 275 23	[3750] 425 23	[5175] 585 22	[6600] 745 21	[7900] 895 19	[8410] 950 18	[9000] 1015 17	[9590] 1085 16	[10450] 1180 14
[6] 23	[1095] 125 35	[2460] 280 35	[3825] 430 35	[5220] 590 34	[6620] 750 33	[7950] 900 31	[8430] 950 30	[8910] 1005 29	[9490] 1070 28	
[8] 30	[1100] 125 48	[2500] 280 48	[3900] 440 47	[5270] 595 46	[6640] 750 45	[7990] 905 43	[8460] 955 43	[8925] 1010 42		
[10] 38	[1130] 130 60	[2550] 290 60	[3975] 450 59	[5320] 600 58	[6670] 755 57	[8045] 910 54	[8595] 970 53	[9150] 1035 52		
[12] 45	[1160] 130 72	[2600] 295 72	[4050] 460 71	[5375] 605 70	[6700] 755 69	[8100] 915 65	[8660] 980 64			
[14] 53	[1105] 125 84	[2535] 285 84	[3965] 450 83	[5325] 600 82	[6685] 755 81	[8065] 910 77	[8620] 975 76			
[16] 61	[1050] 120 96	[2465] 280 95	[3880] 440 95	[5275] 595 94	[6670] 755 93	[8035] 910 89	[8580] 970 88			
[18] 68	[990] 110 108	[2405] 270 107	[3825] 430 107	[5240] 590 105	[6655] 750 104	[7345] 830 100				
[20] 76	[930] 105 121	[2350] 265 120	[3770] 425 120	[5205] 590 118	[6640] 750 116					
[25] 95	[750] 85 151	[2175] 245 150	[3600] 405 149	[5000] 565 147	[6400] 725 146					
[30] 114	[550] 60 181	[1975] 225 180	[3400] 385 179	[4800] 530 177	[6200] 700 176					
[35] 132			[3125] 355 210	[4545] 515 208						
[40] 151			[2850] 320 241	[4295] 485 239						

Motors run with high efficiency in all areas designated with a number for torque and speed, however for best motor life select a motor to run with a torque and speed range shown in the light blue area.

[2850]  
320  
241 } Torque [lb-in]  
Nm  
Speed RPM

Continuous  
Intermittent

Performance data is typical at 120 SUS. Actual data may vary slightly from unit to unit in production

# Dimensions — 4000 Series Standard Motor

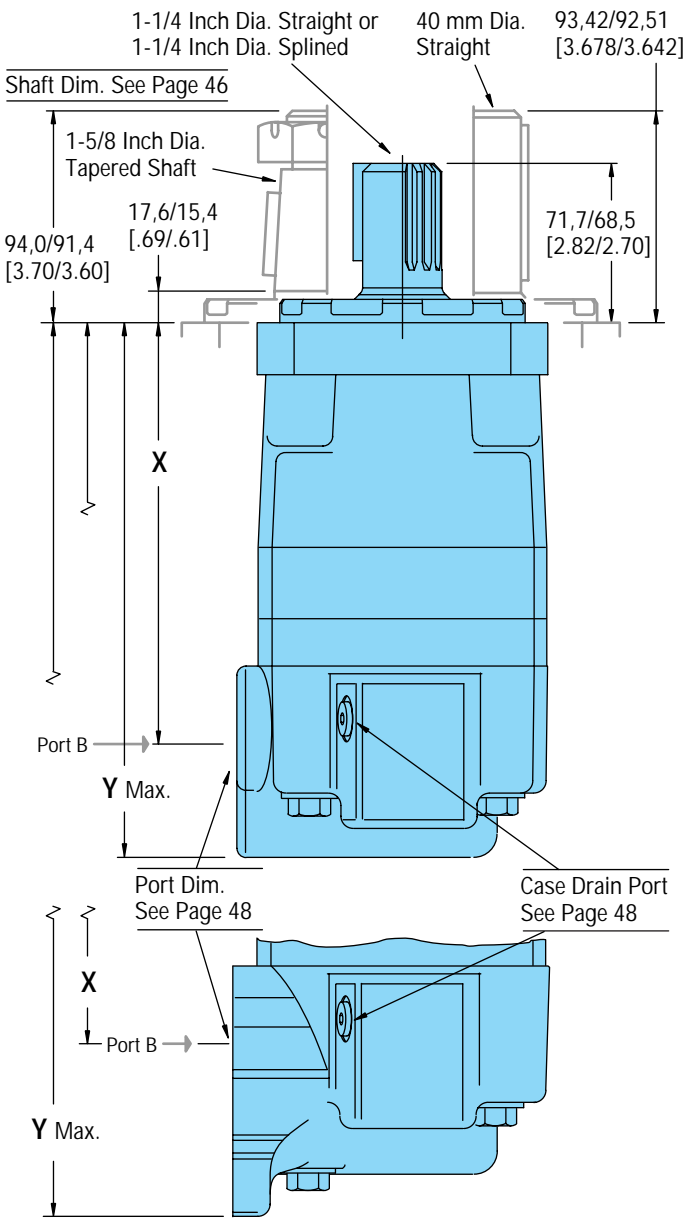

## Standard Flange— Similar to SAE B Type

**Standard Rotation**  
Viewed from Shaft End  
Port A Pressurized — CW  
Port B Pressurized — CCW

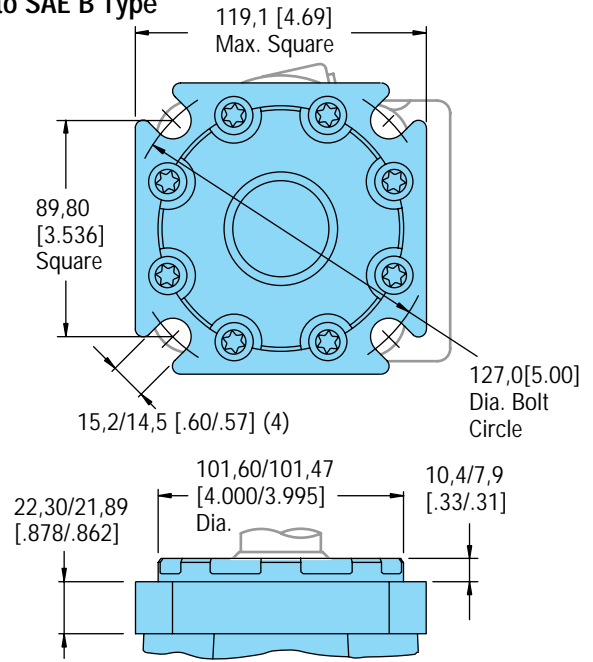

## SAE C Flange

14,53/14,15 [572/557] Dia. Thru Max.

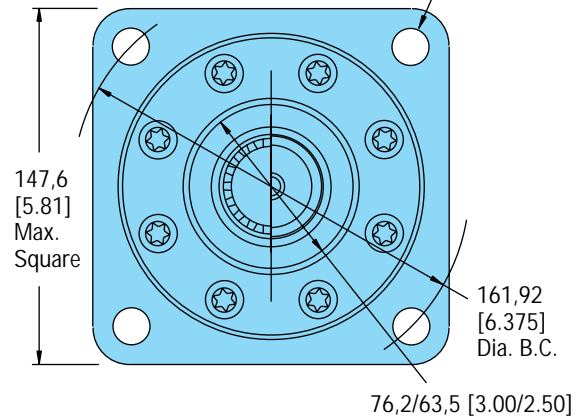

### 4000 Series Standard Motor with 1-1/16-12 O-ring Ports or G 3/4 (BSP) Ports

Displ. cm <sup>3</sup> /r [in <sup>3</sup> /r]	110 [6.7]	130 [7.9]	160 [9.9]	205 [12.5]	245 [15.0]	310 [19.0]	395 [24.0]	495 [30.0]	625 [38.0]
X Dim. mm [inch]	158,3 [6.23]	162,3 [6.39]	168,7 [6.64]	177,2 [6.98]	168,7 [6.64]	177,2 [6.98]	187,9 [7.40]	200,7 [7.90]	217,8 [8.58]
Y Dim. mm [inch]	214,4 [8.44]	218,4 [8.60]	224,7 [8.85]	233,2 [9.18]	224,7 [8.85]	233,2 [9.18]	243,9 [9.60]	256,8 [10.11]	273,9 [10.78]

### 4000 Series Standard Motor with 3/4 inch Split Flange Ports

X Dim. mm [inch]	166,7 [6.57]	170,8 [6.73]	177,0 [6.97]	185,6 [7.31]	177,1 [6.97]	185,6 [7.31]	196,3 [7.73]	209,2 [8.24]	226,2 [8.91]
Y Dim. mm [inch]	246,3 [9.70]	250,4 [9.86]	256,7 [10.11]	265,2 [10.44]	256,7 [10.11]	265,2 [10.44]	275,9 [10.86]	288,8 [11.37]	305,9 [12.04]

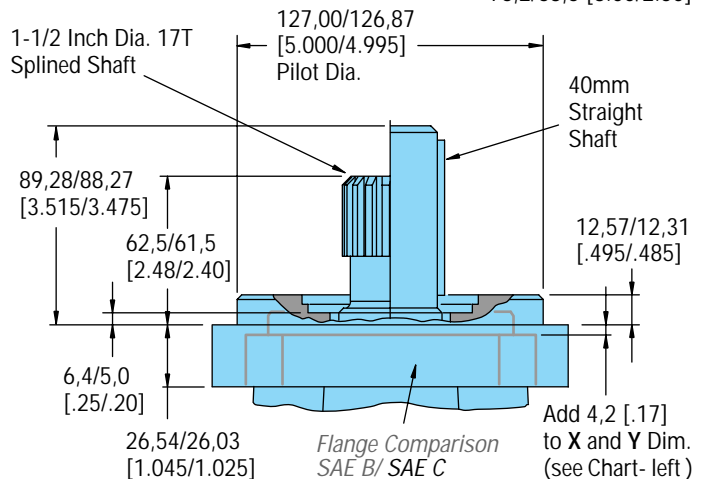

# Dimensions — 4000 Series Wheel Motor

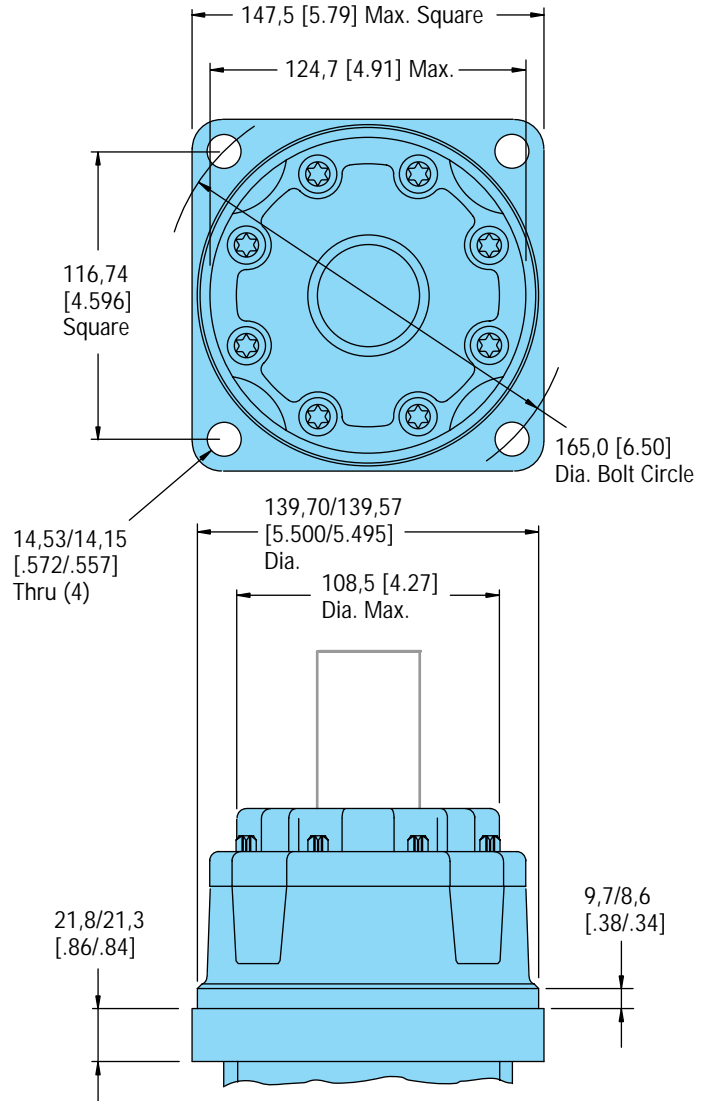
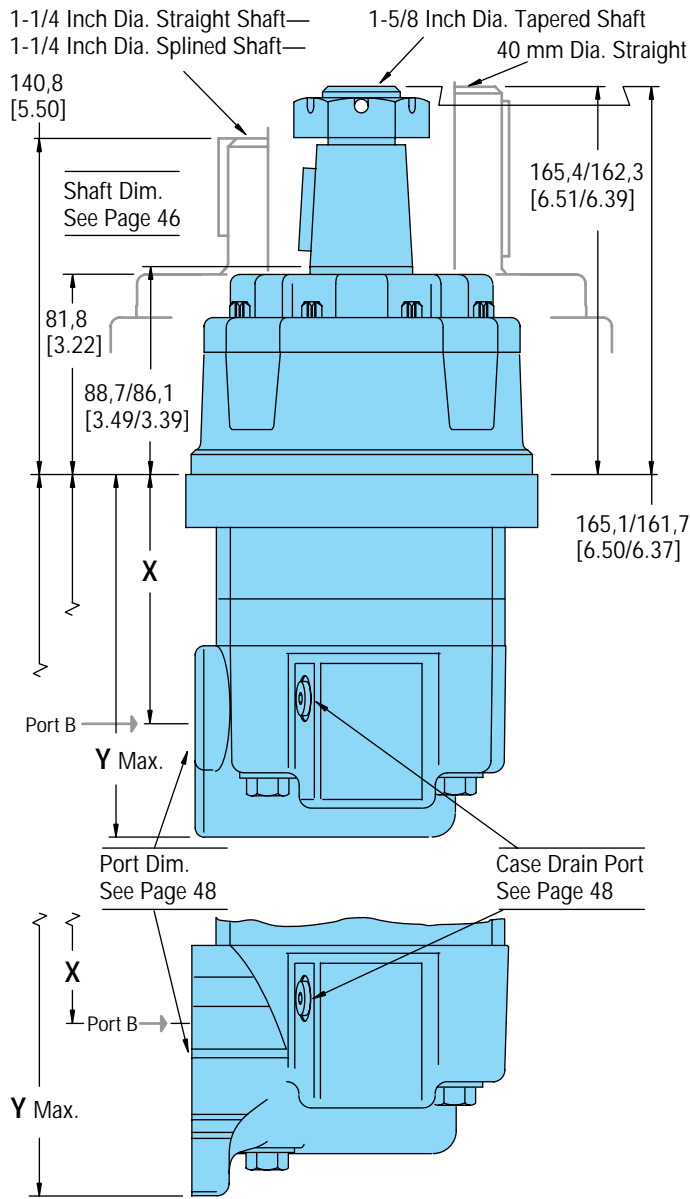

## 4000 Series Wheel Motor with 1-1/16-12 O-ring Ports or G 3/4 (BSP) Ports

Displ. cm <sup>3</sup> /r [in <sup>3</sup> /r]	110 [ 6.7]	130 [ 7.9]	160 [ 9.9]	205 [12.5]	245 [15.0]	310 [19.0]	395 [24.0]	495 [30.0]	625 [38.0]
X Dim. mm [inch]	87,4 [3.44]	91,5 [3.60]	97,8 [3.85]	106,3 [4.19]	97,8 [3.85]	106,3 [4.19]	117,0 [4.61]	129,9 [5.12]	146,8 [5.78]
Y Dim. mm [inch]	143,3 [5.64]	147,3 [5.80]	153,6 [6.05]	162,2 [6.38]	153,6 [6.05]	162,2 [6.38]	172,8 [6.80]	185,8 [7.31]	202,8 [7.98]

## 4000 Series Wheel Motor with 3/4 inch Split Flange Ports

X Dim. mm [inch]	95,0 [3.74]	99,1 [3.90]	105,5 [4.16]	114,0 [4.49]	105,5 [4.16]	114,0 [4.49]	124,7 [4.91]	137,6 [5.42]	154,4 [6.08]
Y Dim. mm [inch]	174,5 [6.87]	178,5 [7.03]	184,9 [7.28]	193,4 [7.61]	184,9 [7.28]	193,4 [7.61]	204,1 [8.03]	217,0 [8.54]	234,0 [9.21]

**Standard Rotation**  
Viewed from Shaft End  
Port A Pressurized — CW  
Port B Pressurized — CCW

# Dimensions — 4000 Series Bearingless Motor

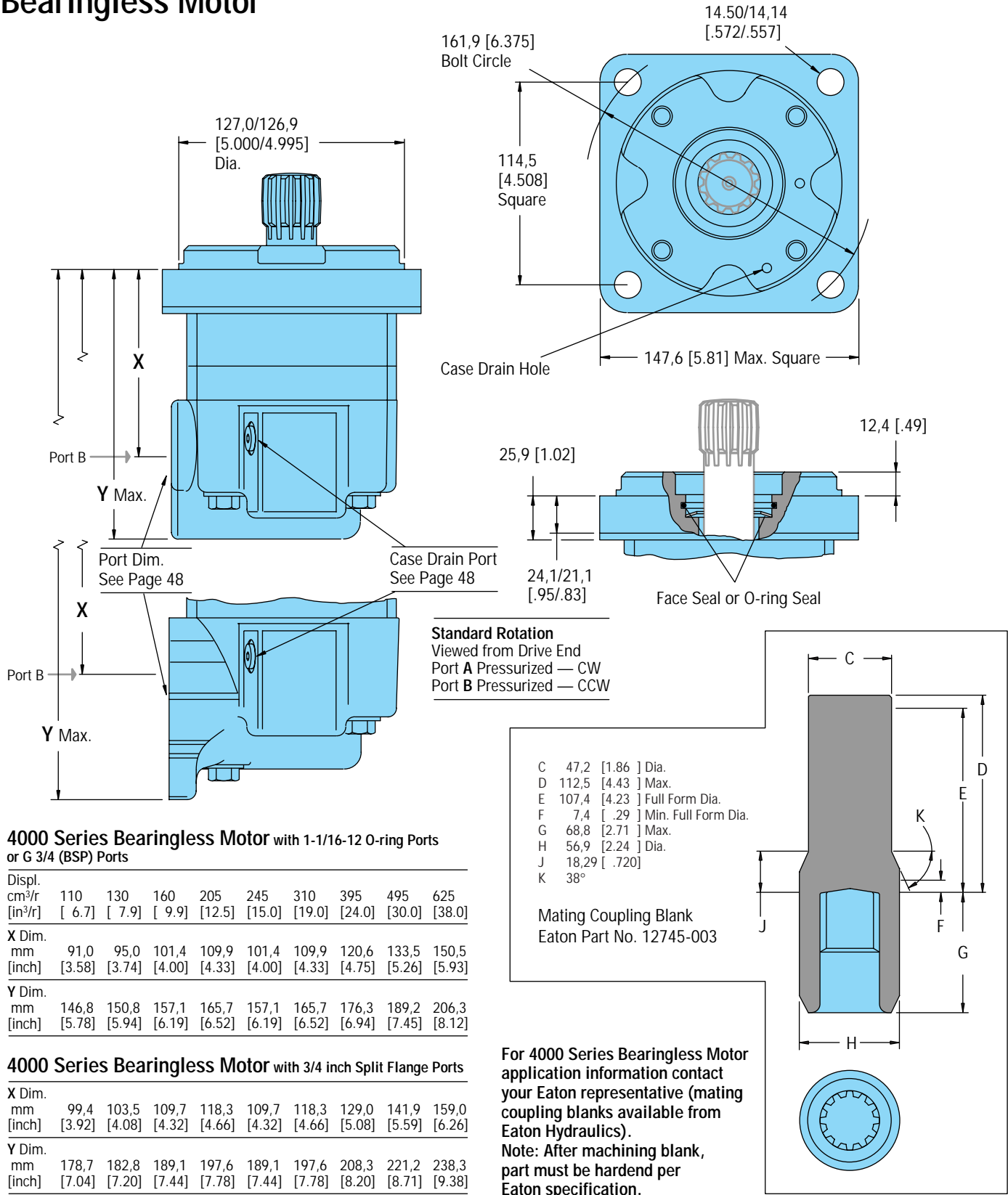

# Bearingless Installation — 4000 Series

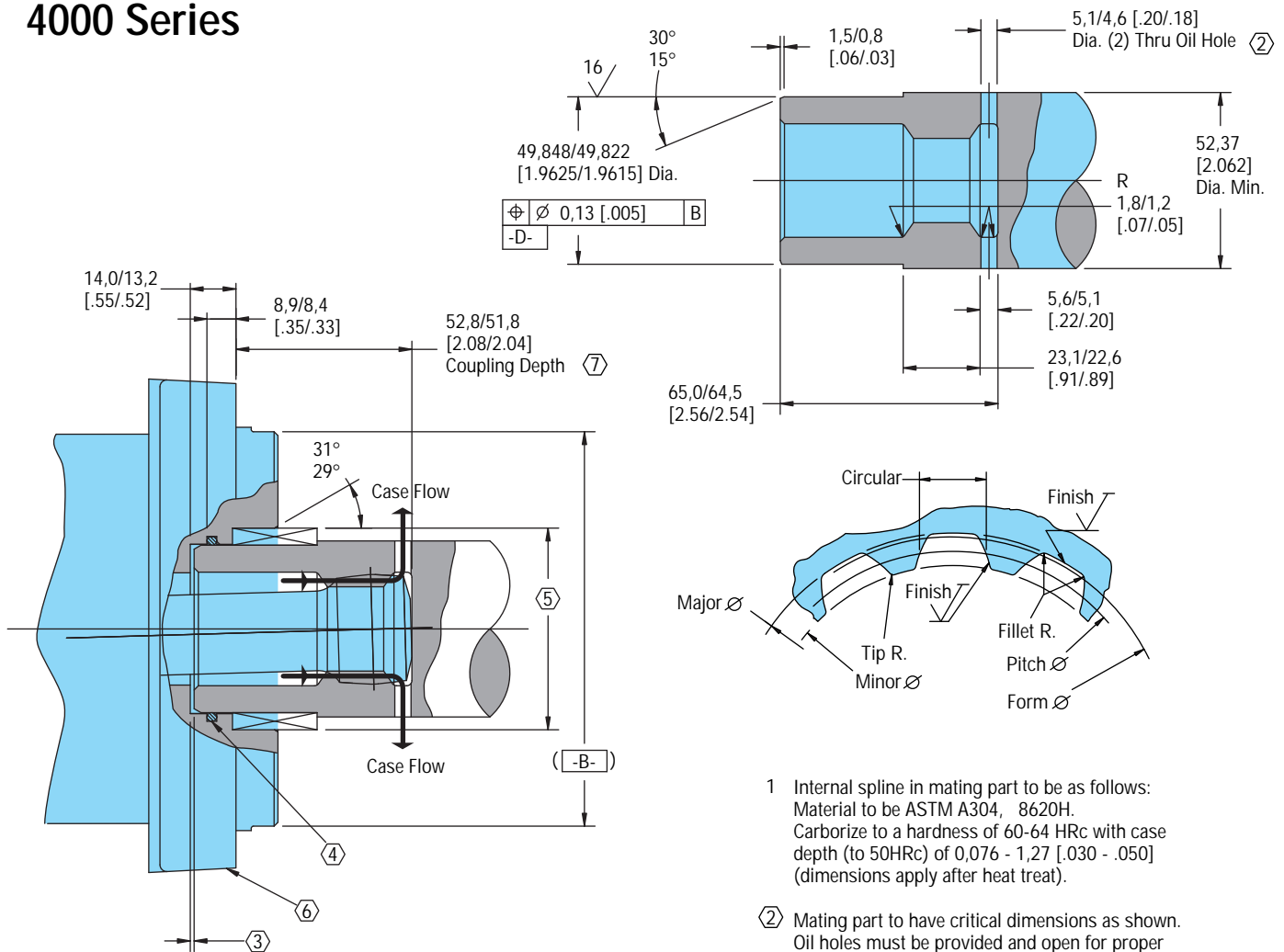

Spline Pitch — 10/20  
 Pressure Angle — 30°  
 Number of teeth — 12  
 Class of Fit — Ref. 5  
 Type of Fit — Side  
 Pitch Diameter — Ref. 30.480000 [1.200000]  $\text{◎}$  0.20 [.008] H  
 Base Diameter — Ref. 26.396455 [1.0392305]  
 Major Diameter — 33.43 [1.316] Max. 33.23 [1.308] Min.  
 Minor Diameter — 28.40 - 28.58 [1.118 - 1.125]  
 Form Diameter, Min. — 32.59 [1.283]  
 Fillet Radius — 0.63 - 0.76 [.025 - .030]  
 Tip Radius — 0.26 - 0.51 [.010 - .020]  
 Finish — 1,6 [63]  
 Involute Profile Variation — +0.000 -0.025 [+0.000 -0.0010]  
 Total Index Variation — 0.038 [.0015]  
 Lead Variation — 0.013 [.0005]  
 Circular Space Width:  
 Maximum Actual — 5.045 [.1986]  
 Minimum Effective — 4.995 [.1951]  
 Maximum Effective — Ref. 5.009 [.1972]  
 Minimum Actual — Ref. 4.986 [.1963]  
 Dimension Between Two Pins — Ref. 22.783 - 22.929 [.8970 - .9027]  
 Pin Diameter — 5.334 [.2100] Pins to Have 3.73 [.147] Wide Flat for Root Clearance

- 1 Internal spline in mating part to be as follows:  
 Material to be ASTM A304, 8620H.  
 Carborize to a hardness of 60-64 HRc with case depth (to 50HRc) of 0,076 - 1,27 [.030 - .050] (dimensions apply after heat treat).
- 2 Mating part to have critical dimensions as shown. Oil holes must be provided and open for proper oil circulation.
- 3 Some means of maintaining clearance between shaft and mounting flange must be provided.
- 4 Seal to be furnished with motor for proper oil circulation thru splines.
- 5 Counterbore designed to adapt to a standard sleeve bearing 50,010 - 50,040 [1.9689 - 1.9700] ID by 60,050 - 60,080 [2.3642 - 2.3653] (Oilite bronze sleeve bearing).
- 6 Similar to SAE "C" Four Bolt Flange.
- 7 52,8 [2.08] Max. dimension to be maintained when assembling, shipping and installing unit to insure valve drive engagement with valve (this is required on displacement code number 24 only).

## Dimensions — Shafts 4000 Series

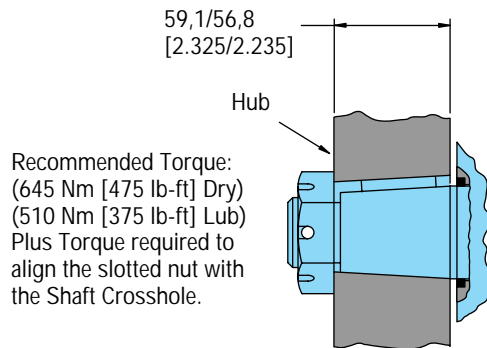
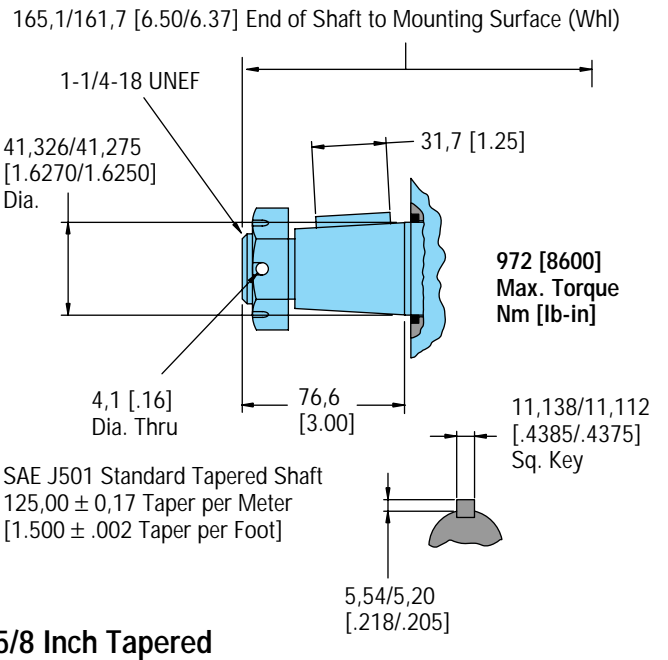
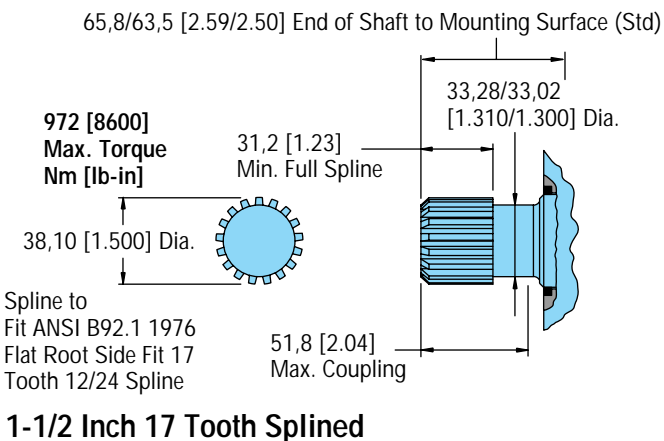
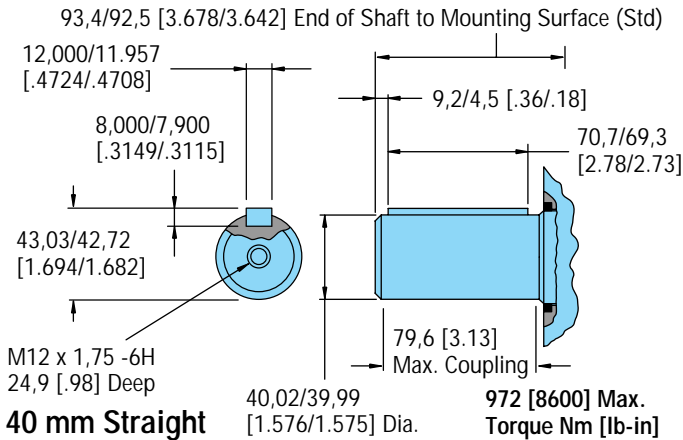
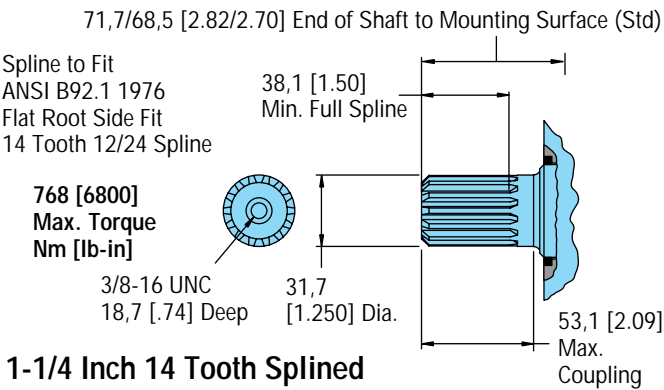
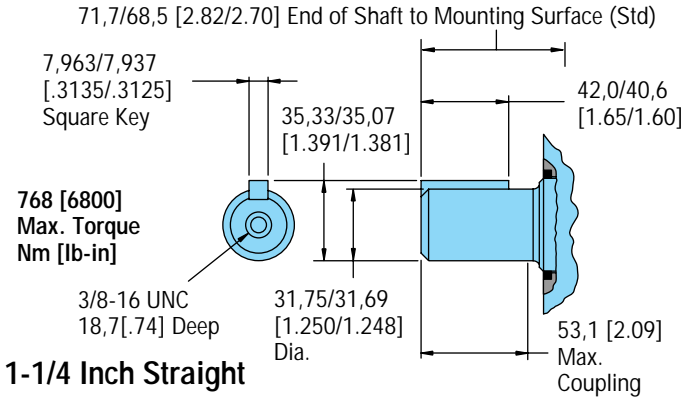

### Tapered Shaft Hub Data

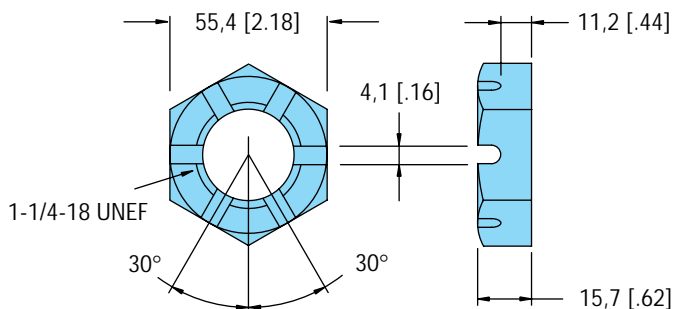

### Slotted Hexagon Nut

# Shaft Side Load Capacity 4000 Series

These curves indicate the radial load capacity on the motor shaft(s) at various locations.

The curve is based on **B 10 Bearing life (2000 hours or 12,000,000 shaft revolutions at 100 RPM ) at rated output torque.** To determine radial load at speeds other than 100 RPM, multiply the load values given on the bearing curve by the factors in the chart below.

RPM	Multiplication Factor
50	1.23
100	1.00
200	.81
300	.72
400	.66
500	.62
600	.58
700	.56
800	.54

For 3,000,000 Shaft revolutions or 500 hours — Increase these shaft loads 52%.

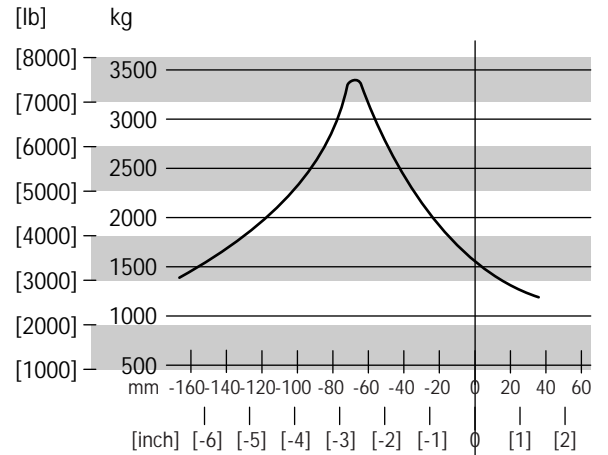

Wheel Motor  
Tapered  
Shaft

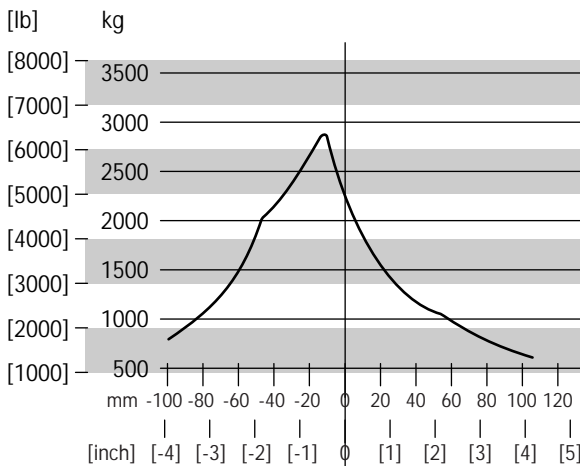
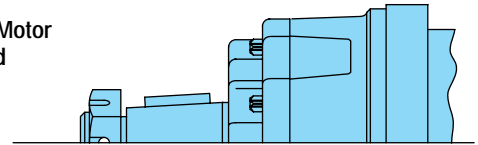

Standard Motor  
Straight  
Shaft

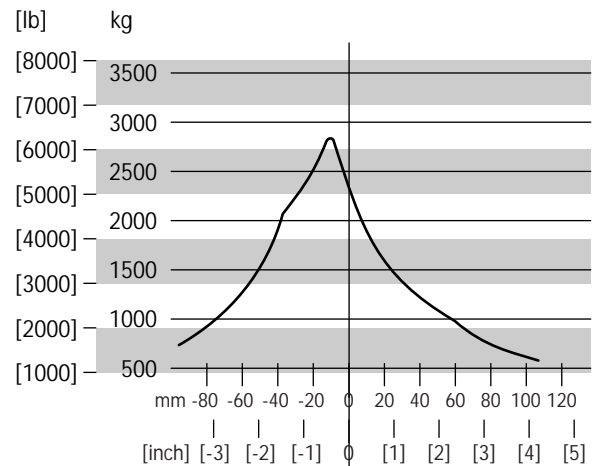
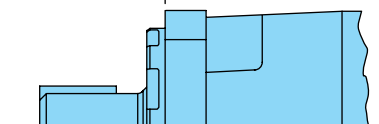

Standard Motor  
Splined  
Shaft

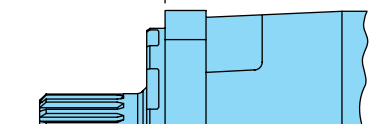

# Dimensions — Ports 4000 Series

## 4000 Series with Shuttle Valve

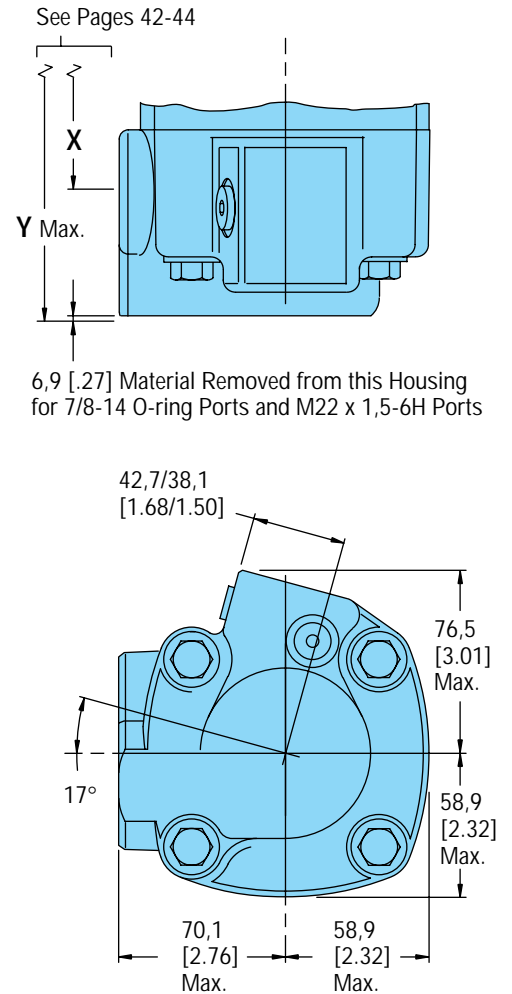
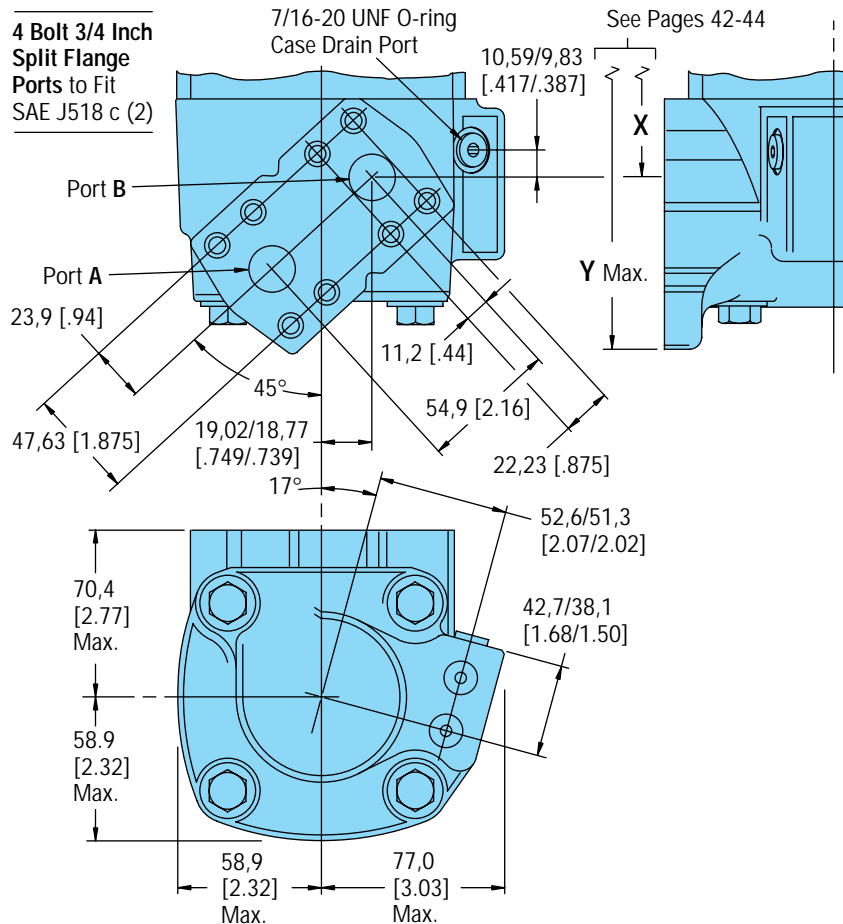
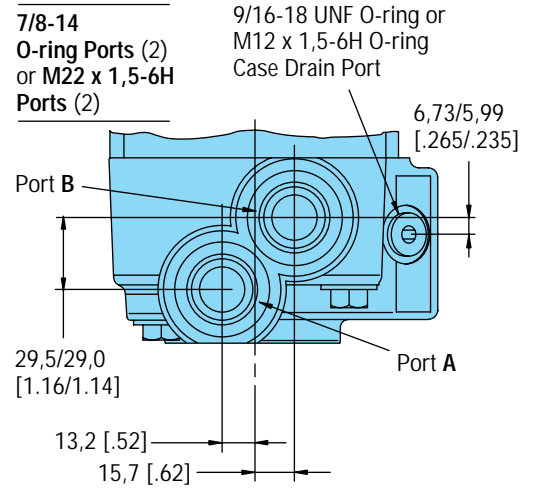
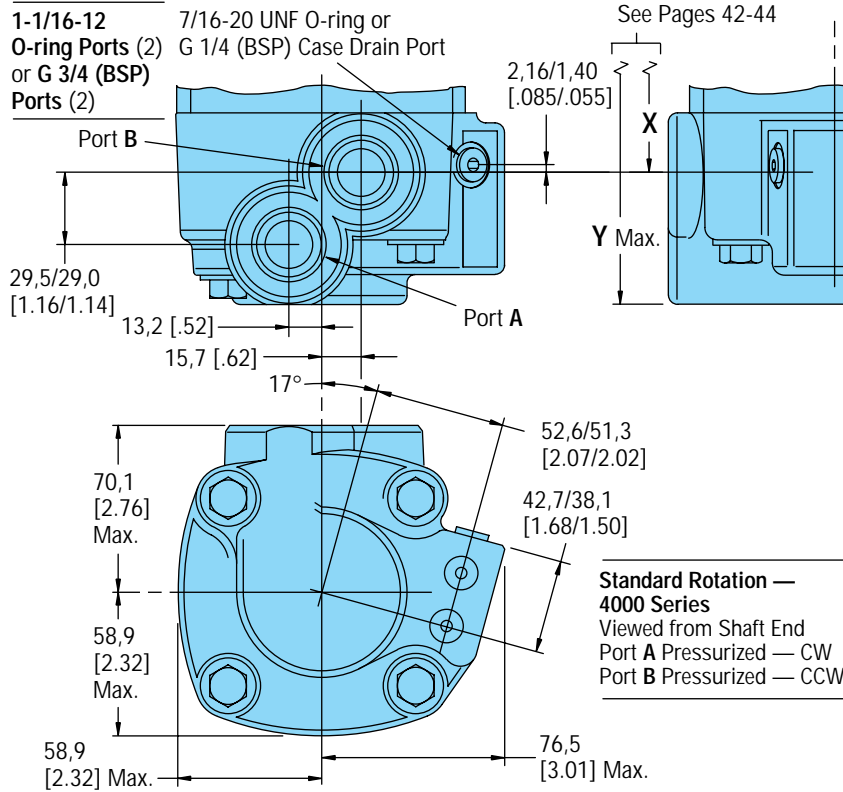



# Product Numbers 4000 Series

## Product Numbers—4000 Series Motors

Use digit prefix —**109-**, **110-**, or **111-** plus four digit number from charts for complete product number—Example **111-1057**.  
**Orders will not be accepted without three digit prefix.**

Mounting	Shaft	Ports	Displ. cm <sup>3</sup> /r [ in <sup>3</sup> /r] Product Number								
			110 [ 6.7]	130 [ 7.9]	160 [ 9.9]	205 [12.5]	245 [15.0]	310 [19.0]	395 [24.0]	495 [30.0]	625 [38.0]
Standard SAE B-Mount	1-1/4 inch Straight	1-1/16 O-ring	109-1100	-1101	-1102	-1103	-1104	-1105	-1106	-1212	-1215
		3/4 inch Split Flange	109-1001	-1054	-1002	-1003	-1055	-1056	-1057	—	—
	1-5/8 Inch Tapered	1-1/16 O-ring	109-1107	-1108	-1109	-1110	-1111	-1112	-1113	—	—
		3/4 inch Split Flange	109-1006	-1058	-1007	-1008	-1059	-1402	-1061	—	—
	1-1/4 Inch 14 T Splined	1-1/16 O-ring	109-1114	-1115	-1116	-1117	-1118	-1119	-1120	—	—
		3/4 inch Split Flange	109-1011	-1062	-1012	-1013	-1063	-1064	-1065	—	—
Standard SAE C-Mount	40 mm Straight	G 3/4 (BSP)	109-1184	-1185	-1227	-1224	-1225	-1189	-1190	—	—
	1-1/2 Inch 17 T Splined	G 3/4 (BSP)	109-1191	-1192	-1193	-1194	-1195	-1196	-1197	—	—
	1-1/4 inch Straight	1-1/16 O-ring	110-1074	-1075	-1076	-1077	-1078	-1079	-1080	—	-1122
3/4 inch Split Flange		110-1001	-1040	-1002	-1003	-1041	-1042	-1043	—	—	
Wheel Motor	40 mm Straight	G 3/4 (BSP)	110-1108	-1109	-1110	-1111	-1112	-1113	-1125	—	—
	1-5/8 Inch Tapered	1-1/16 O-ring	110-1081	-1082	-1083	-1084	-1085	-1086	-1087	1116	-1117
		3/4 inch Split Flange	110-1006	-1044	-1007	-1008	-1045	-1046	-1047	—	—
	1-1/4 Inch 14 T Splined	1-1/16 O-ring	110-1088	-1089	-1090	-1091	-1092	-1093	-1094	—	—
		3/4 inch Split Flange	110-1011	-1048	-1012	-1013	-1049	-1050	-1051	—	—
	Bearingless		1-1/16 O-ring	111-1033	-1034	-1035	-1036	-1037	-1038	-1039	-1062
3/4 inch Split Flange			111-1044	-1015	-1045	-1046	-1016	-1017	-1018	—	—
G 3/4 (BSP)			111-1052	-1053	-1054	-1055	-1056	-1057	-1058	—	—

111-1057

For 4000 Series Motors with a configuration *Not Shown* in the charts above: Use model code number system on page 50 to specify product in detail.

# Model Code for 4000 Series Motors

The following 14-digit coding system has been developed to identify all of the configuration options for the 4000 Series Motor. Use this model code to specify a motor with the desired features. All 14-digits of the code must be present when ordering. You may want to photocopy the matrix below to ensure that each number is entered in the correct box.

## Model Code — 4000 Series Disc Valve Motors

1	2	3	4	5	6	7	8	9	10	11	12	13	14
M	0	4										0	0

**Position 1 Product Series**

**M** ..... Motor

**Position 2, 3 4000 Series**

**04** ..... 4000 Series

**Position 4, 5 Displacement cm<sup>3</sup>/r [in<sup>3</sup>/r]**

- 07** ..... 110 [ 6.7]
- 08** ..... 130 [ 7.9]
- 10** ..... 160 [ 9.9]
- 12** ..... 205 [12.5]
- 15** ..... 245 [15.0]
- 17** ..... 280 [17.1]\*
- 19** ..... 310 [19.0]
- 24** ..... 395 [24.0]
- 30** ..... 495 [30.0]
- 38** ..... 625 [38.0]

\* For performance and dimension data contact your Eaton Hydraulics representative.

**Position 6 Mounting Flange**

- A** ..... 4 Bolt (Bearingless 127,0 [5.00] Pilot Dia. and 14,27 [.562] Dia. Mounting Holes 161,9 [6.38] Dia. B.C.
- B** ..... 4 Bolt (SAE B) (Standard) 101,6 [4.00] Pilot Dia. and 14,7 [.58] Mounting Slots on 127,0 [5.00] Dia. B.C.
- C** ..... 4 Bolt (Wheel) 139,7 [5.50] Pilot Dia. and 14,3 [.56] Dia. Mounting Holes on 165,1 [6.50] Dia. B.C.
- F** ..... 4 Bolt (SAE C) (Standard) 127,0 [5.00] Pilot Dia. and 14,3 [.56] Dia. Mounting Holes on 161,9 [6.38] Dia. B.C.

**Position 7, 8 Output Shaft**

- 00** ..... Bearingless
- 01** ..... 1-1/4 inch Dia. Straight with Straight Key, 3/8-16 Threaded Hole and 53,1 [2.09] Max. Coupling Length
- 02** ..... 1-5/8 inch Dia. Tapered with Straight Key and 1-1/4 - 18 UNEF Slotted Hex. Nut
- 03** ..... 1-1/4 inch Dia. Splined 14T with 38,1 [1.50] Min. Full Spline Length and 53,1 [2.09] Max. Coupling Length
- 13** ..... 1-1/2 inch Dia. Splined 17T with 31,2 [1.23] Min. Full Spline Length
- 14** ..... 40 mm Dia. Straight with Straight Key, M12 x 1,75 - 6H Threaded Hole

**Position 9 Port Type**

- B** ..... 1-1/16 - 12 O-ring with 7/16-20 O-ring Case Drain and Check Valve
- C** ..... G 3/4 (BSP) O-ring with G 1/4 (BSP) O-ring Case Drain and Check Valve
- D** ..... 3/4 inch 4 Bolt Split Flange with 7/16-20 O-ring Case Drain and Check Valve
- A** ..... 7/8-14 O-ring with 9/16-18 O-ring Case Drain with Hot Oil Shuttle Valve
- H** ..... M22 x 1,5-6H (ISO) O-ring with M12 x 1,5-6H O-ring Case Drain with Hot Oil Shuttle Valve

**Position 10, 11 Special Features (Hardware)**

- 00** ..... None
- 01** ..... Viton Shaft Seal
- 07** ..... Viton Seals
- 13** ..... Seal Guard
- 17** ..... Speed Sensor (Std.)

**Position 12 Paint/Special Packaging**

- 0** ..... No Paint
- A** ..... Painted Low Gloss Black
- C** ..... Corrosion Protected

**Position 13 Eaton Assigned Code when Applicable**

- 0** ..... Assigned Code

**Position 14 Eaton Assigned Design Code**

- 0** ..... Assigned Design Code

# Specifications

## 6000 Series

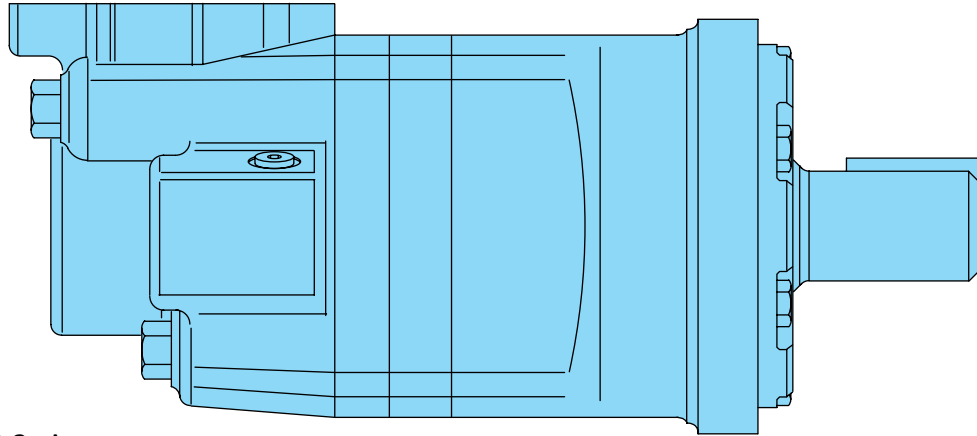

### Specification Data—6000 Series

Displ. cm <sup>3</sup> /r [in <sup>3</sup> /r]		195 [11.9]	245 [15.0]	310 [19.0]	390 [23.9]	490 [30.0]	625 [38.0]	985 [60.0]	
Max. Speed (RPM) @ ..... Flow	Continuous	775	615	485	387	307	241	153	
	Intermittent	866	834	698	570	454	355	230	
Flow LPM [GPM]	Continuous	150 [40]	150 [40]	150 [40]	150 [40]	150 [40]	150 [40]	150 [40]	
	Intermittent	170 [45]	210 [55]	225 [60]	225 [60]	225 [60]	225 [60]	225 [60]	
Torque Nm [lb-in]	★ 1-3/4 Inch Dia. Tapered Shaft	Continuous	575 [5100]	735 [6510]	930 [ 8230]	1155 [10230]	1445 [12800]	1480 [13100]	1685 [14920]
		Intermittent	860 [7620]	1100 [9740]	1355 [11990]	1635 [14490]	1885 [16670]	1898 [16800]	1875 [16580]
Pressure Δ Bar [Δ PSI]	★ 1-3/4 Inch Dia. Tapered Shaft	Continuous	205 [3000]	205 [3000]	205 [3000]	205 [3000]	205 [3000]	170 [2500]	140 [2000]
		Intermittent	310 [4500]	310 [4500]	310 [4500]	310 [4500]	275 [4000]	221 [3200]	140 [2000]
		Peak	310 [4500]	310 [4500]	310 [4500]	310 [4500]	310 [4500]	240 [3500]	170 [2250]

Maximum Case Pressure - without Case Drain \* — 70 Bar [1000 PSI]

**A simultaneous maximum torque and maximum speed NOT recommended.** For permissible continuous and intermittent operating combinations of pressure and flow refer to performance data on pages 52-53.

★ **Maximum torque for 1-1/2 inch shaft** — 1325 Nm [11750 lb-in] Continuous and 1650 Nm [14600 lb-in] intermittent.

\* For back pressure over 70 Bar [1000 PSI] use an external case drain. Install case drain lines so that the motor case remains filled at all times.

**Maximum inlet pressure** — 310 Bar [4500 PSI]. Do not exceed Δ pressure rating (see chart above).

\* **Maximum return pressure** — 310 Bar [4500 PSI]. Do not exceed Δ pressure rating (see chart above).

Δ Bar [Δ PSI] — True pressure difference between inlet port and outlet port.

**Continuous Rating** — Motor may be run continuously at these ratings.

**Intermittent Operation** — 10% of every minute.

**Peak Operation** — 1% of every minute.

**Recommended Fluids** — Premium quality, anti-wear type hydraulic oil with a viscosity of not less than 70 SUS at operating temperature (see page 81).

**Recommended Maximum System Operating Temp.** — Is 82° C [180° F]

**Recommended Filtration** — per ISO Cleanliness Code, level 18/13

To assure best motor life, run motor for approximately one hour at 30% of rated pressure before application to full load. Be sure motor is filled with fluid prior to any load applications.





# Dimensions — 6000 Series Standard Motor

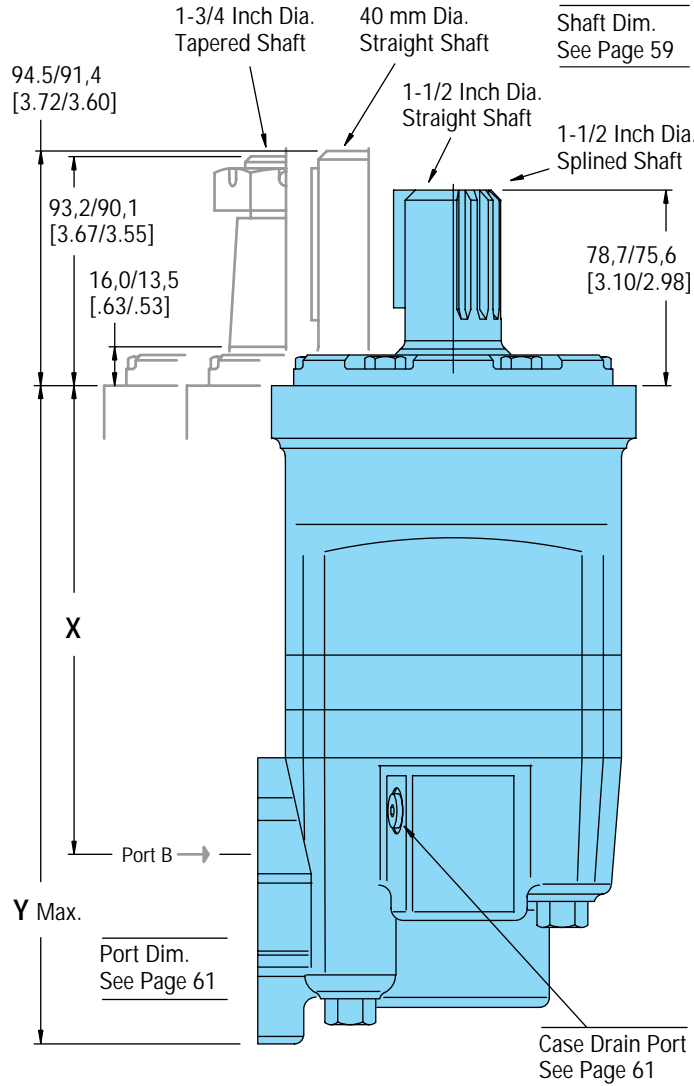

**Standard Rotation**  
Viewed from Shaft End  
Port A Pressurized — CW  
Port B Pressurized — CCW

### Standard SAE CC Flange

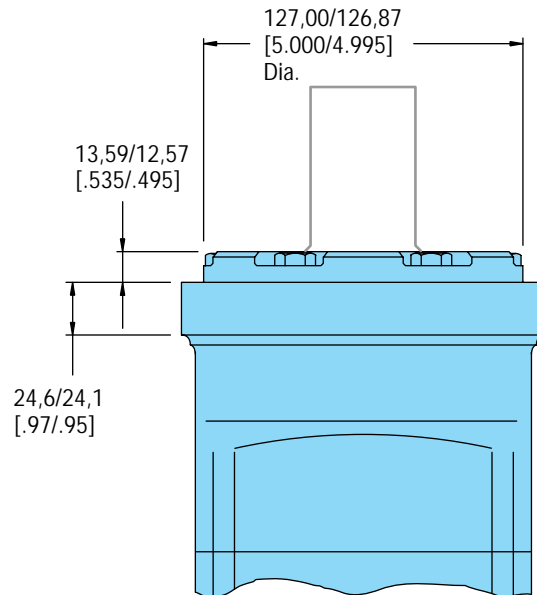
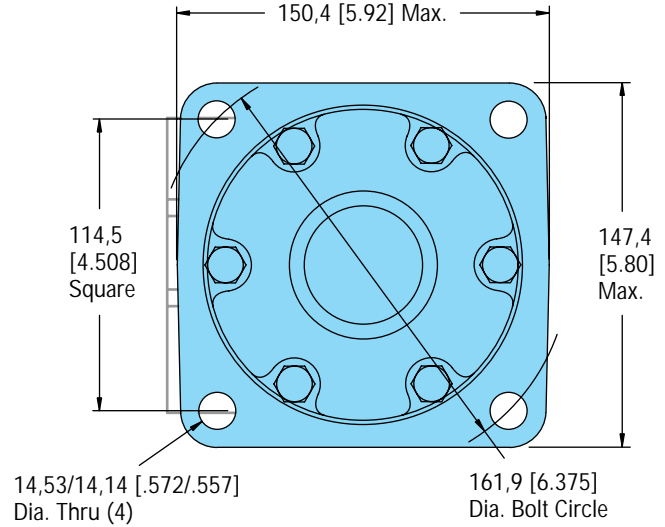

### 6000 Series Standard Motor with 1-5/16-12 O-ring Ports, G 1 (BSP) Ports, and 3/4 inch Split Flange Ports

Displ. cm <sup>3</sup> /r [in <sup>3</sup> /r]	195 [11.9]	245 [15.0]	310 [19.0]	390 [23.9]	490 [30.0]	625 [38.0]	985 [60.0]
X Dim. mm [inch]	187,7 [ 7.39]	193,3 [ 7.61]	200,7 [ 7.90]	209,3 [ 8.24]	220,5 [ 8.68]	235,2 [ 9.26]	274,8 [10.82]
Y Dim. mm [inch]	270,1 [10.63]	275,6 [10.85]	283,0 [11.14]	291,6 [11.48]	302,8 [11.92]	318,5 [12.54]	357,4 [14.07]

# Dimensions — 6000 Series Wheel Motor

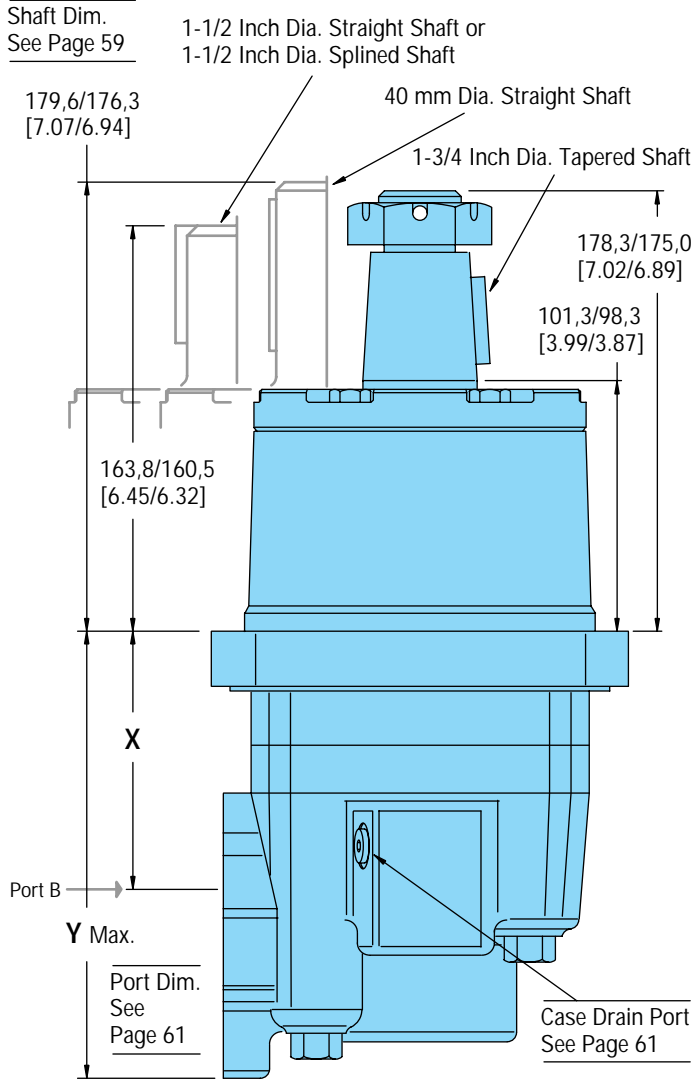

**Standard Rotation**  
Viewed from Shaft End  
Port A Pressurized — CW  
Port B Pressurized — CCW

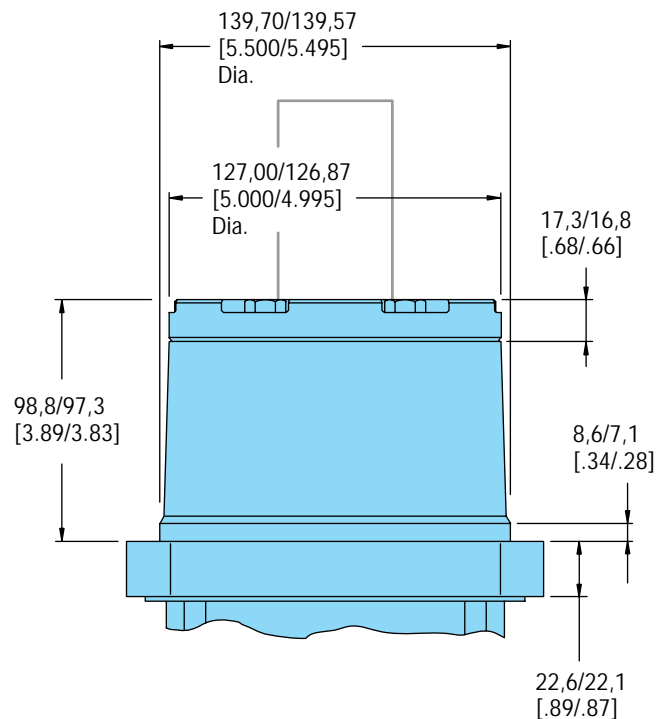
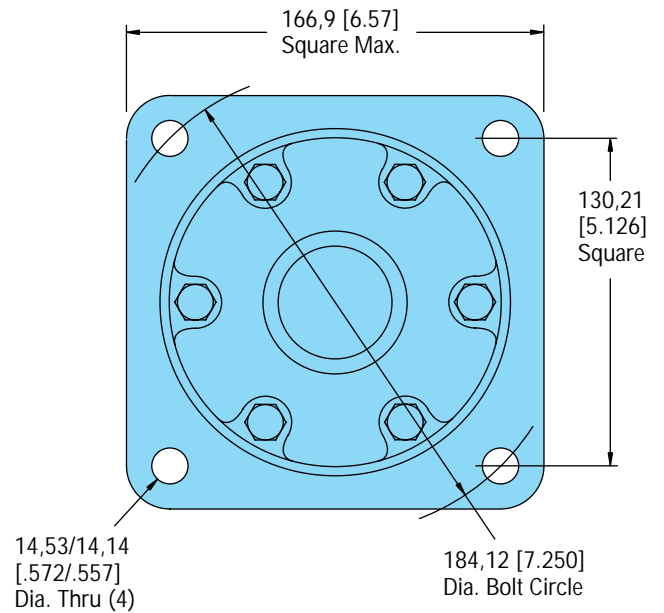

**6000 Series Wheel Motor with 1-5/16-12 O-ring Ports, G 1 (BSP) Ports, and 3/4 inch Split Flange Ports**

Displ. cm <sup>3</sup> /r [in <sup>3</sup> /r]	195 [11.9]	245 [15.0]	310 [19.0]	390 [23.9]	490 [30.0]	625 [38.0]	985 [60.0]
X Dim. mm [inch]	102,9 [4.05]	108,4 [4.27]	115,8 [4.56]	124,7 [4.91]	135,6 [5.34]	149,9 [5.90]	190,0 [7.48]
Y Dim. mm [inch]	185,2 [7.29]	190,8 [7.51]	198,2 [7.80]	207,1 [8.15]	218,0 [8.58]	233,0 [9.17]	272,6 [10.73]

# Dimensions — 6000 Series Global Mount (Similar to ISO 3019/2)

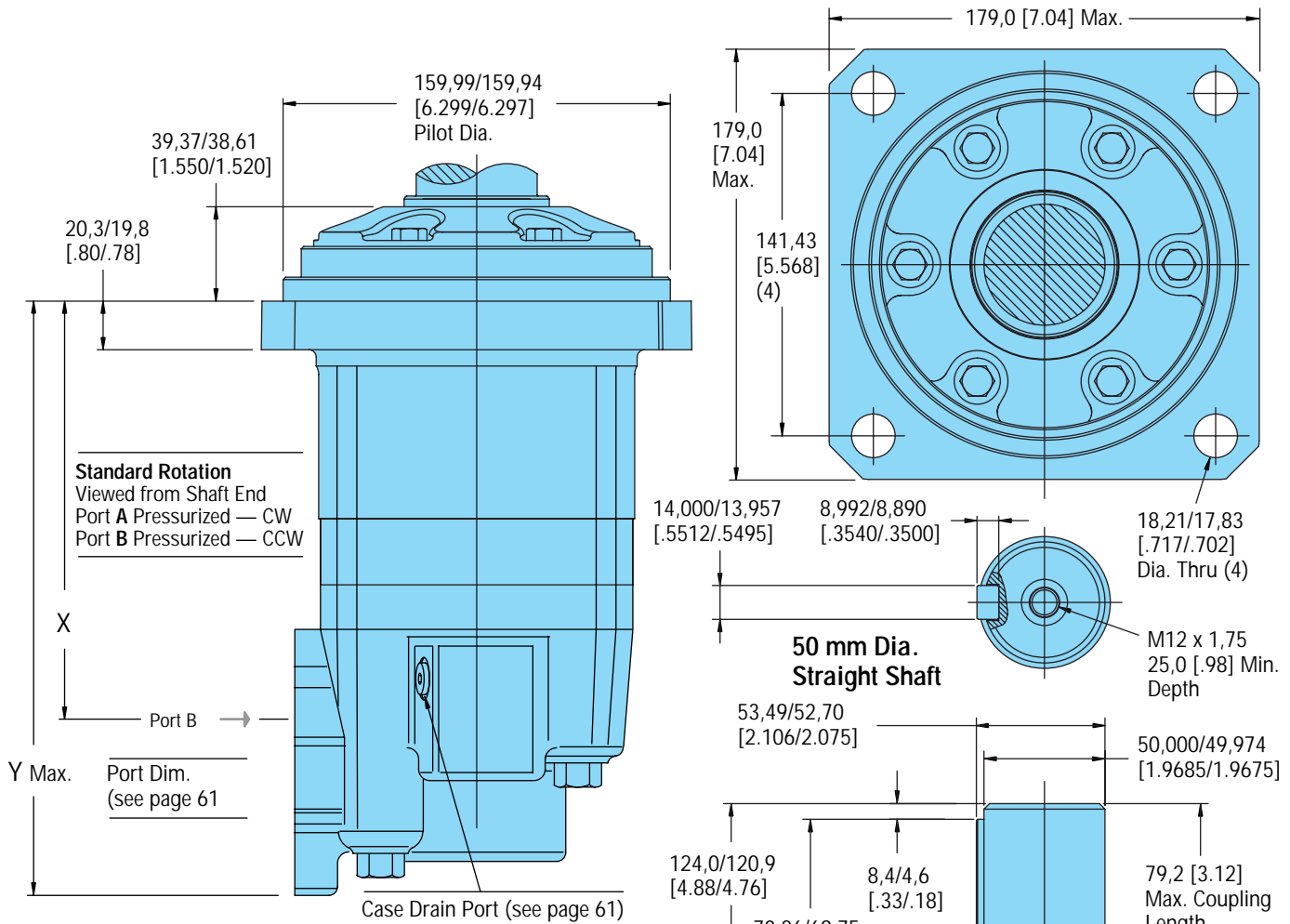

6000 Series Standard Motor with G 1 (BSP) Ports

Displ. cm <sup>3</sup> /r [in <sup>3</sup> /r]	310 [19.0]	390 [24.0]	490 [30.0]	625 [38.0]	800 [45.0]	800 [49.0]	985 [60.0]
X Dim. mm [inch]	182,4 [ 7.18]	191,0 [ 7.52]	202,2 [ 7.96]	216,7 [ 8.54]	229,4 [ 9.03]	236,7 [ 9.32]	256,5 [10.10]
Y Dim. mm [inch]	262,6 [10.34]	271,5 [10.69]	282,4 [11.12]	297,2 [11.70]	309,6 [12.19]	317,0 [12.48]	337,0 [13.27]



# Dimensions — 6000 Series Bearingless Motor

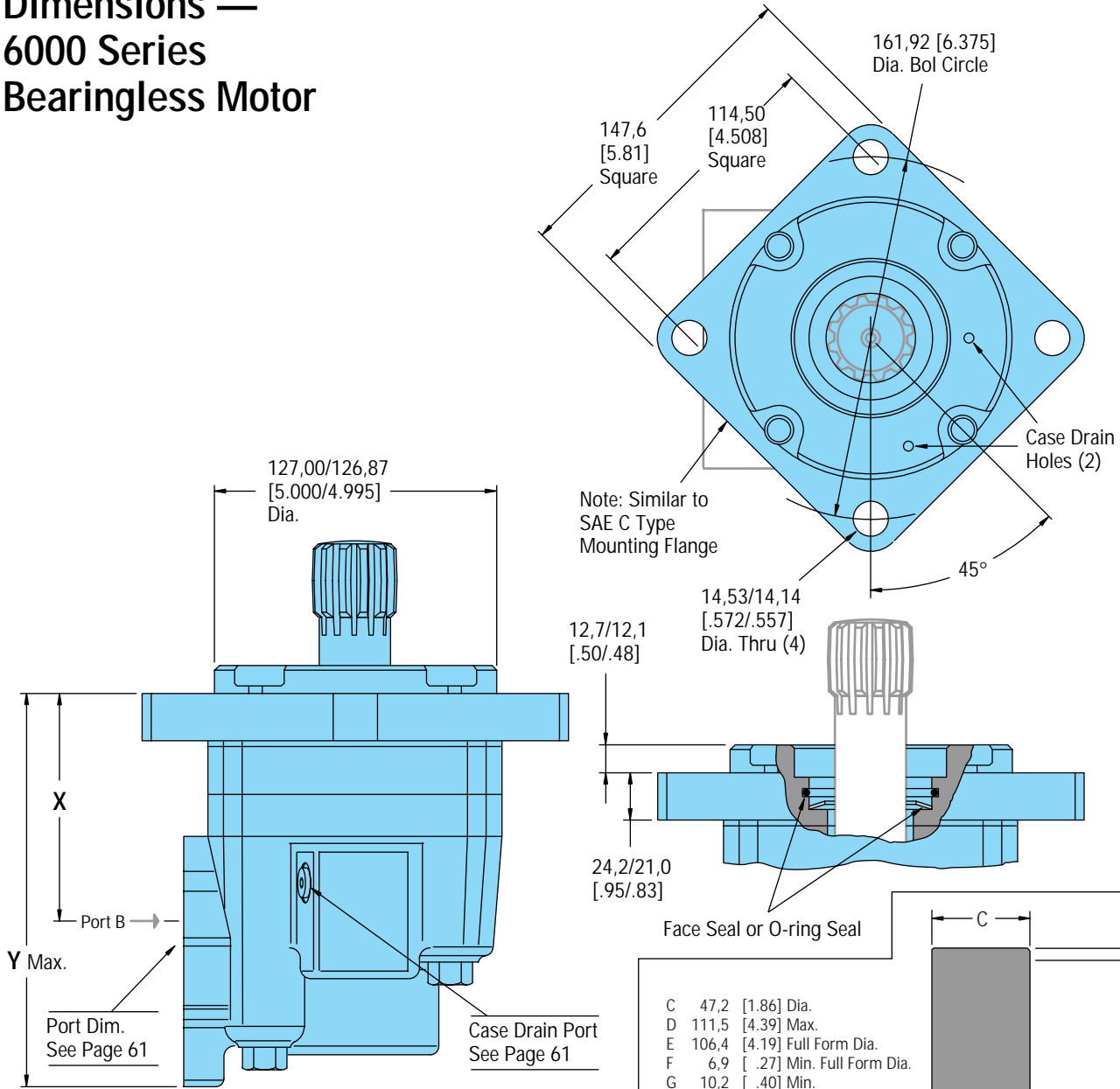

**Standard Rotation**  
Viewed from Drive End  
Port A Pressurized — CW  
Port B Pressurized — CCW

**6000 Series Bearingless Motor with 1-5/16-12 O-ring Ports, G 1 (BSP) Ports, 3/4 inch Split Flange Ports**

Displ. cm <sup>3</sup> /r [in <sup>3</sup> /r]	195 [11.9]	245 [15.0]	310 [19.0]	390 [23.9]	490 [30.0]	625 [38.0]	985 [60.0]
X Dim. mm [inch]	105,7 [ 4.16]	111,2 [ 4.38]	118,3 [ 4.66]	127,5 [ 5.02]	138,7 [ 5.46]	152,9 [ 6.02]	193,0 [ 7.60]
Y Dim. mm [inch]	188,0 [ 7.40]	193,6 [ 7.62]	200,7 [ 7.90]	209,6 [ 8.25]	220,8 [ 8.69]	235,5 [ 9.27]	275,1 [10.83]

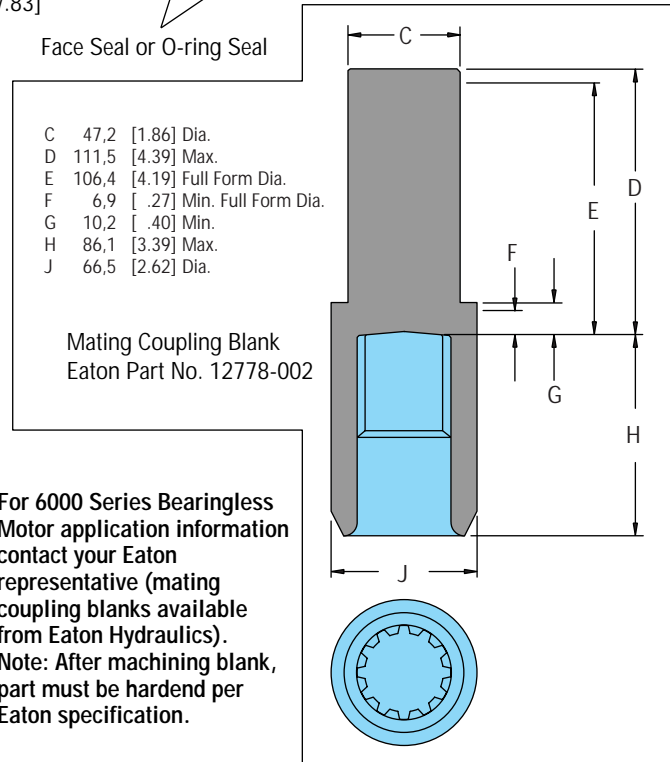

# Bearingless Installation — 6000 Series

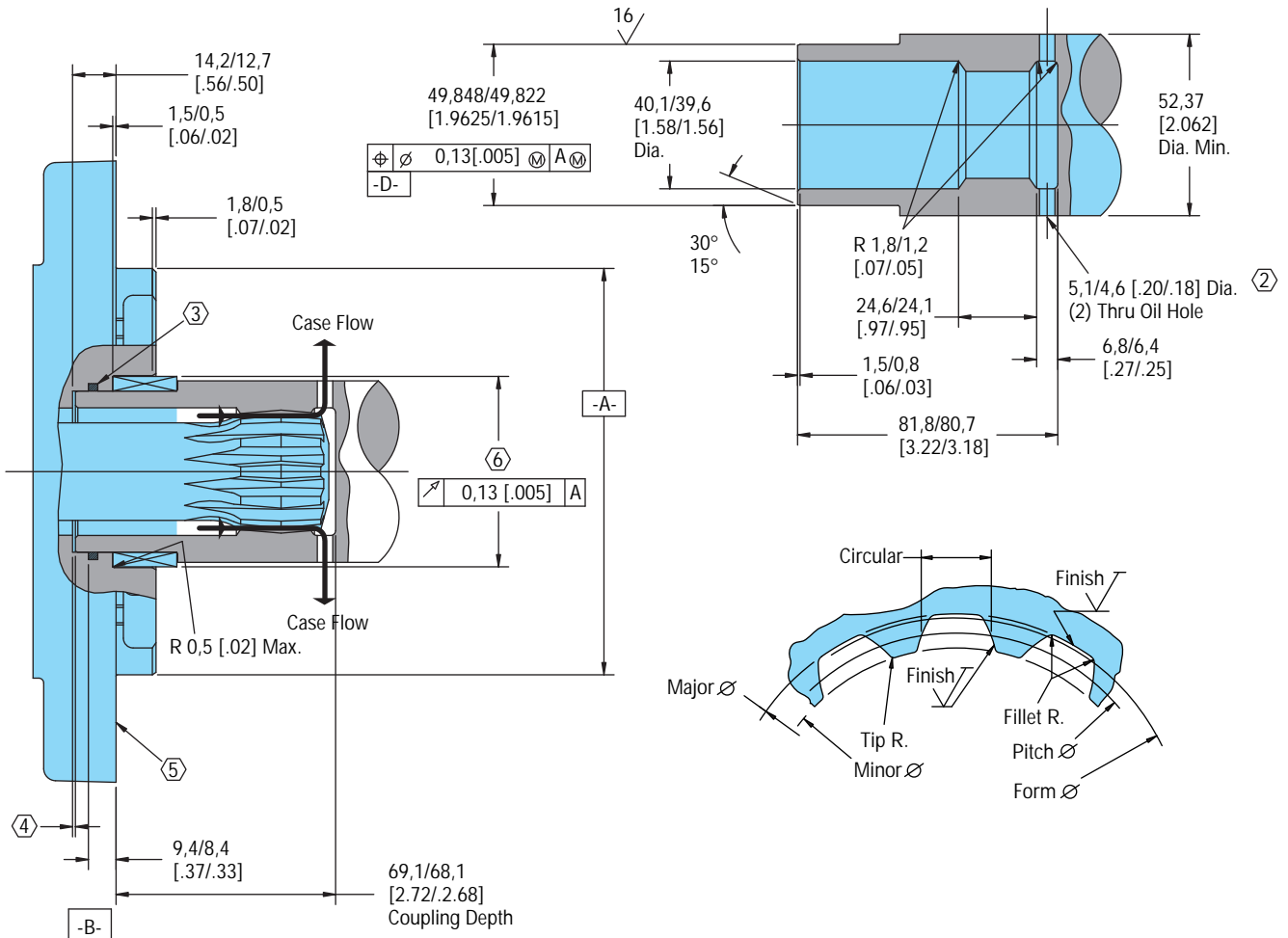

Spline Pitch — 8.5/17  
 Pressure Angle — 30°  
 Number of teeth — 12  
 Class of Fit — Ref. 5  
 Type of Fit — Side  
 Pitch Diameter — Ref. 35,858823 [ 1.4117647]  $\text{Ⓢ} 0,20 [ .008] H$   
 Base Diameter — Ref. 31,054652 [ 1.2226241]  
 Major Diameter — 39,17 [ 1.542] Max. 38,97 [ 1.534] Min.  
 Minor Diameter — 33,30 - 33,48 [ 1.311 - 1.318]  
 Form Diameter, Min. — 38,33 [ 1.509]  
 Fillet Radius — 0,64 - 0,76 [ .025 - .030]  
 Tip Radius — 0,25 - 0,51 [ .010 - .020]  
 Finish — 1,6 [ 63]  
 Involute Profile Variation — +0,000 -0,025 [ +.0000 - .0010]  
 Total Index Variation — 0,038 [ .0015]  
 Lead Variation — 0,013 [ .0005]  
 Circular Space Width:  
 Maximum Actual — 5,898 [ .2322]  
 Minimum Effective — 5,804 [ .2285]  
 Maximum Effective — Ref. 5,857 [ .2306]  
 Minimum Actual — Ref. 5,834 [ .2297]  
 Dimension Between Two Pins — Ref. 26,929 - 27,084 [ 1.0602 - 1.0663]  
 Pin Diameter — 6,223 [ .2450] Pins to Have 4,0 [ .160] Wide Flat for Root Clearance

- 1 Internal spline in mating part to be as follows:  
 Material to be ASTM A304, 8620H.  
 Carborize to a hardness of 60-64 HRC with case depth (to 50HRC) of 0,076 - 1,02 [ .030 - .040] (dimensions apply after heat treat).
- 2 Mating part to have critical dimensions as shown. Oil holes must be provided and open for proper oil circulation.
- 3 Some means of maintaining clearance between shaft and mounting flange must be provided.
- 4 Seal to be furnished with motor for proper oil circulation thru splines.
- 5 Similar to SAE "C" Four Bolt Flange.
- 6 Counterbore designed to adapt to a standard sleeve bearing 50,010 - 50,038 [ 1.9689 - 1.9700] ID by 60,051 - 60,079 [ 2.3642 - 2.3653] O.D. (Oilite bronze sleeve bearing).

# Dimensions — Shafts

## 6000 Series

78,6/75,8 [3.10/2.98] End of Shaft to Mounting Surface (Std)

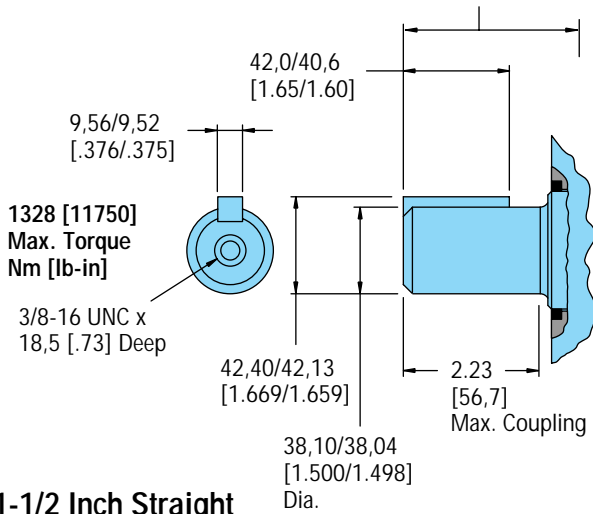

**1-1/2 Inch Straight**

178,1/175,0 [7.02/6.89] End of Shaft to Mounting Surface (Whl)

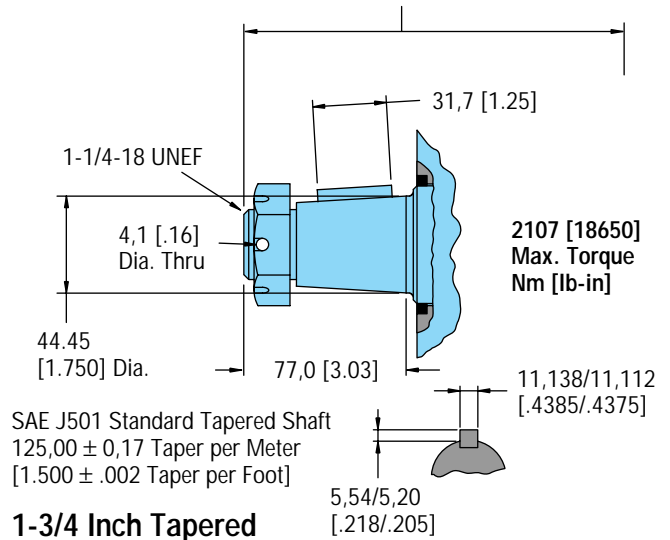

**1-3/4 Inch Tapered**

78,6/75,8 [3.10/2.98] End of Shaft to Mounting Surface (Std)

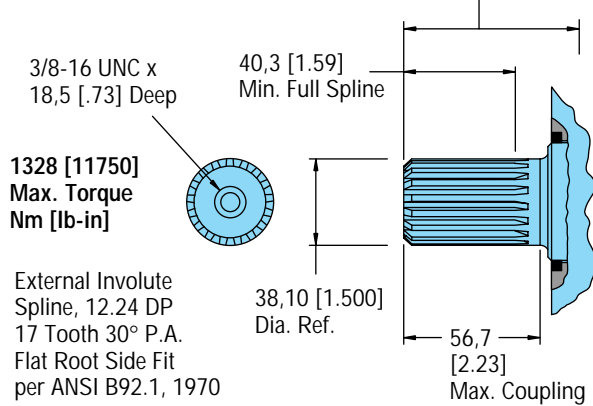

**1-1/2 Inch 17 Tooth Splined**

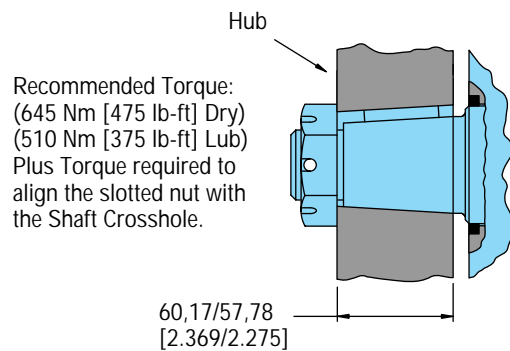

**Tapered Shaft Hub Data**

94,4/91,6 [3.72/3.60] End of Shaft to Mounting Surface (Std)

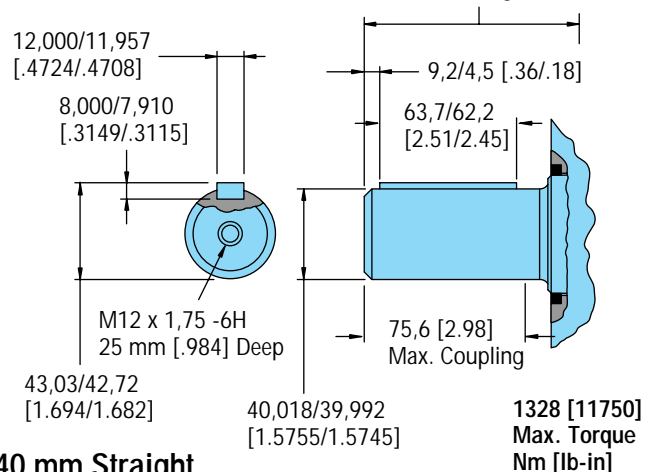

**40 mm Straight**

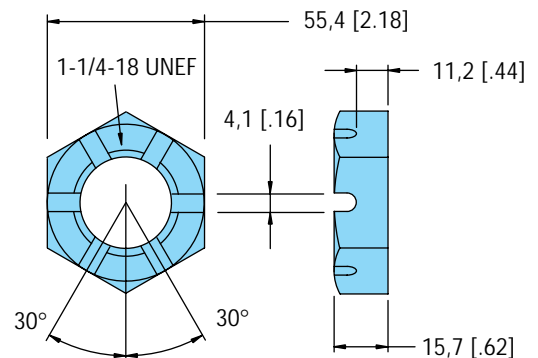

**Slotted Hexagon Nut**

# Shaft Side Load Capacity 6000 Series

These curves indicate the radial load capacity on the motor shaft(s) at various locations.

The curve is based on B 10 Bearing life (2000 hours or 12,000,000 shaft revolutions at 100 RPM ) at rated output torque. To determine radial load at speeds other than 100 RPM, multiply the load values given on the bearing curve by the factors in the chart below.

RPM	Multiplication Factor
50	1.23
100	1.00
200	.81
300	.72
400	.66
500	.62
600	.58
700	.56
800	.54

For 3,000,000 Shaft revolutions or 500 hours — Increase these shaft loads 52%.

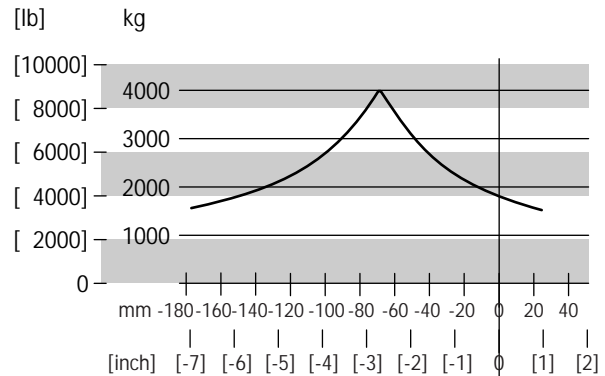

Wheel Motor  
Tapered  
Shaft

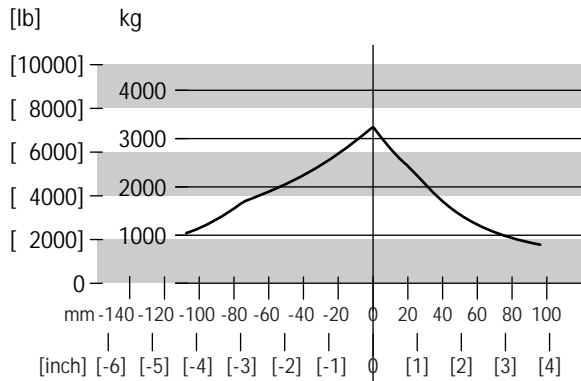
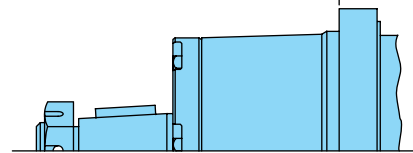

Standard Motor  
Straight  
Shaft

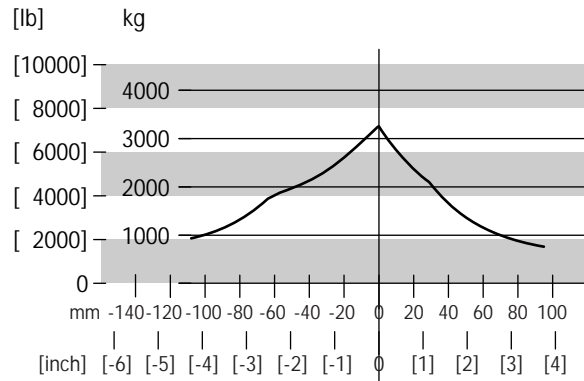
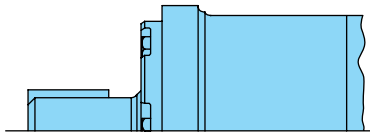

Standard Motor  
Splined  
Shaft

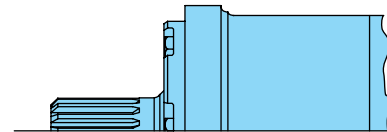

# Dimensions — Ports 6000 Series

# 6000 Series with Shuttle Valve

1-5/16-12 O-ring Ports (2)  
or G 1 (BSP) Ports (2)

7/16-20 UNF O-ring or  
G 1/4 (BSP) Port  
Case Drain

See Pages 54-57

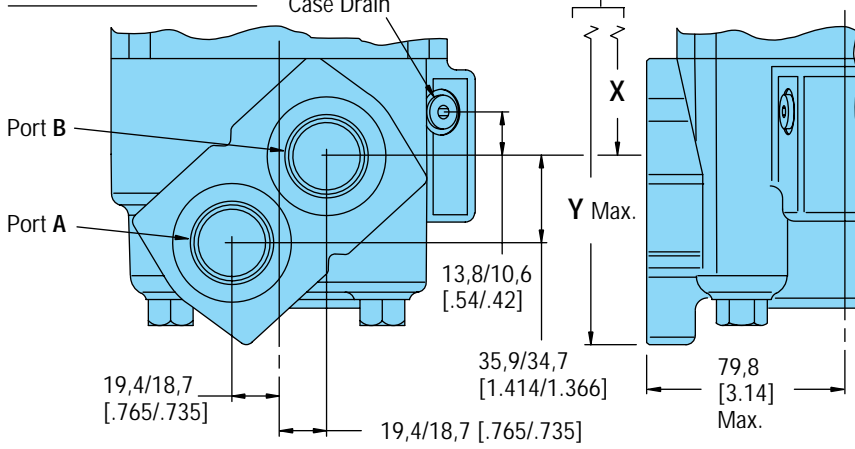

1-5/16-12 O-ring Ports (2) with Shuttle

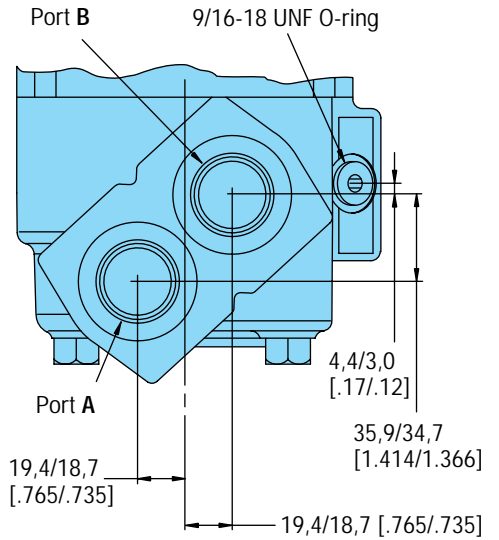

4 Bolt 3/4 Inch Split Flange  
Ports to Fit SAE J518c (2)  
Except for 20,0 [.79] Min. Thd. Dp.

Port B

See Pages 54-57

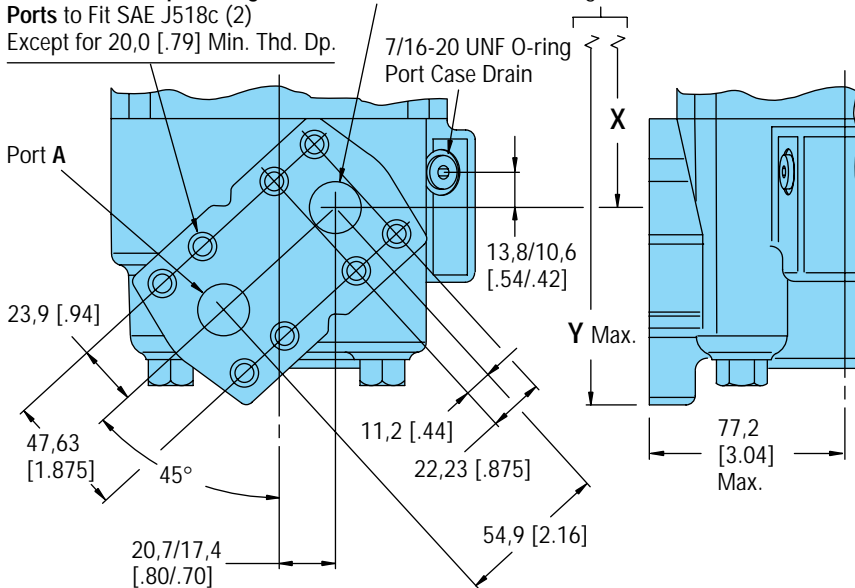

See Pages 54-57

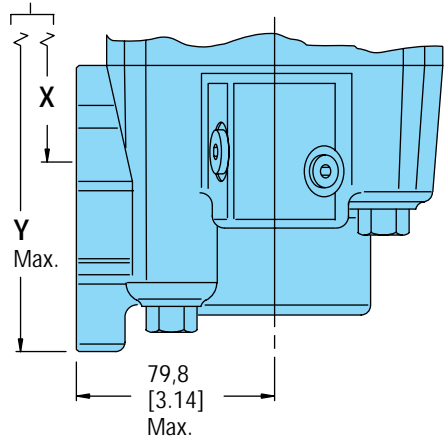

6000 Series  
Motor  
End View—  
Common  
Dim.

17°

58,0/56,3  
[2.28/2.22]

Standard Rotation — 6000 Series  
Viewed from Shaft End  
Port A Pressurized — CW  
Port B Pressurized — CCW

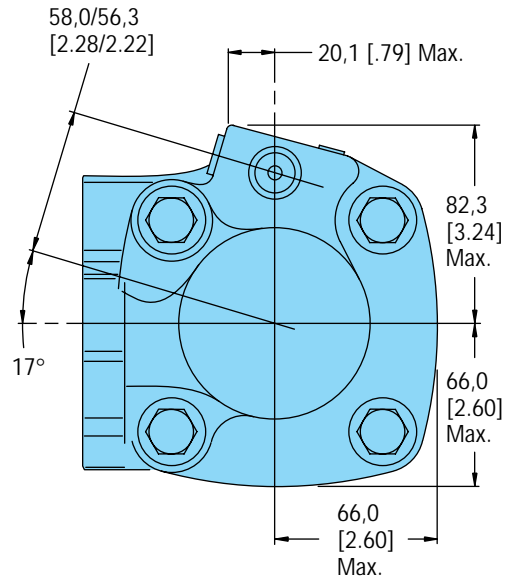
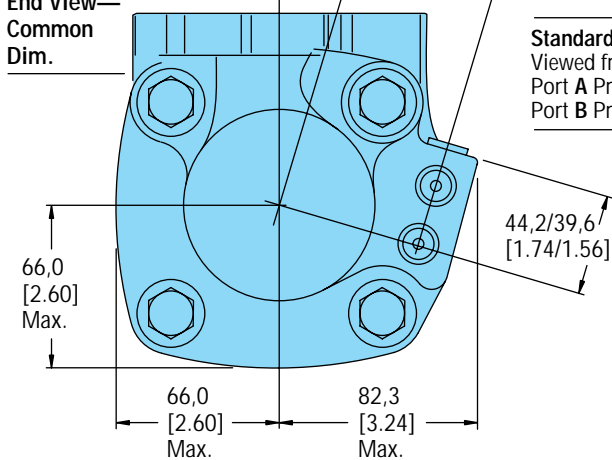

# Product Numbers 6000 Series

## Product Numbers—6000 Series Motors

Use digit prefix —112-, 113-, or 114- plus four digit number from charts for complete product number—Example 114-1047.  
Orders will not be accepted without three digit prefix.

Mounting	Shaft	Ports	Displacement cm <sup>3</sup> /r [ in <sup>3</sup> /r ] and Product Number						
			195 [11.9]	245 [ 15.0]	310 [19.0]	390 [23.9]	490 [30.0]	625 [38.0]	985 [60.0]
Standard	1-1/2 Inch Straight	1-5/16 O-ring	112-1064	-1065	-1066	-1067	-1068	-1107	-1069
	40 mm Straight	G 1 (BSP)	112-1094	-1095	-1096	-1097	-1098	—	-1099
	1-1/2 Inch 17 T Splined	1-5/16 O-ring	112-1058	-1059	-1060	-1061	-1062	-1109	-1063
		G 1 (BSP)	112-1088	-1089	-1090	-1091	-1092	—	-1093
Wheel Motor	40 mm Straight	G 1 (BSP)	113-1082	-1083	-1084	-1085	-1086	-1100	-1087
	1-3/4 Inch Tapered	1-5/16 O-ring	113-1070	-1071	-1072	-1073	-1074	-1093	-1075
Bearingless		1-5/16 O-ring	114-1031	-1032	-1033	-1034	-1035	-1055	-1036
		G 1 (BSP)	114-1043	-1044	-1045	-1046	-1047	—	-1048

114-1047

## Product Numbers – 6000 Series

Mounting Type - Standard (Code H), 4 Bolt:

- 160,0 [6.30] Pilot Dia.
- 18,01 [.709] Dia. Mounting Holes
- 200,0 [7.87] Dia. Bolt Circle

Output Shaft - Straight (Code 21)

Ports - G1 (BSP) Staggered G 1/4 Case Drain (Code C)

Paint - Low Gloss Black (Code A)

Use digit prefix —112- plus four digit number from charts for complete product number—Example 112-1215.  
Orders will not be accepted without three digit prefix.

112-1215

Mounting	Shaft	Ports	Displacement cm <sup>3</sup> /r [ in <sup>3</sup> /r ] and Product Number						
			310 [19.0]	390 [23.9]	490 [30.0]	625 [38.0]	737 [45.0]	800 [49.0]	985 [60.0]
Standard	50 mm Straight	G 1 (BSP)	112-1217	-1218	-1215	-1216	-1247	-1219	-1220

For 6000 Series Motors with a configuration *Not Shown* in the charts above: Use model code number system on page 63 to specify product in detail.

# Model Code for 6000 Series Motors

The following 14-digit coding system has been developed to identify all of the configuration options for the 6000 Series Motor. Use this model code to specify a motor with the desired features. All 14-digits of the code must be present when ordering. You may want to photocopy the matrix below to ensure that each number is entered in the correct box.

## Model Code — 6000 Series Disc Valve Motors

1	2	3	4	5	6	7	8	9	10	11	12	13	14
M	0	6										0	0

**Position 1 Product Series**

**M**..... Motor

**Position 2, 3 6000 Series**

**06**..... 6000 Series

**Position 4, 5 Displacement cm<sup>3</sup>/r [in<sup>3</sup>/r]**

**12**..... 195 [11.9]

**15**..... 245 [15.0]

**19**..... 310 [19.0]

**24**..... 390 [23.9]

**30**..... 490 [30.0]

**38**..... 625 [38.0]

**45**..... 740 [45.0]\*

**49**..... 805 [49.0]\*

**60**..... 985 [60.0]

\* For performance and dimension data contact your Eaton Hydraulics representative.

**Position 6 Mounting Flange**

**A**..... 4 Bolt (Bearingless 127,0 [5.00] Pilot Dia. and 14,3 [.56] Dia. Mounting Holes 161,9 [6.38] Dia. B.C.

**B**..... 4 Bolt (SAE CC) (Standard) 127,0 [5.00] Pilot Dia. and 14,3 [.56] Mounting Holes on 161,9 [6.38] Dia. B.C.

**C**..... 4 Bolt (Wheel) 139,7 [5.50] Pilot Dia. and 14,3 [.56] Dia. Mounting Holes on 184,1 [7.25] Dia. B.C.

**H**..... 4 Bolt (Global) (Standard) 160,0 [6.30] Pilot Dia. and 18,0 [.709] Dia. Mounting Holes on 200,0 [7.87] Dia. Bolt Circle

**Position 7, 8 Output Shaft**

**00**..... Bearingless

**01**..... 1-1/2 inch Dia. Straight with Straight Key, 3/8-16 Threaded Hole and 56,7 [2.23] Max. Coupling Length

**02**..... 1-3/4 inch Dia. Tapered with Straight Key and 1-1/4 - 18 UNEF Slotted Hex. Nut

**03**..... 1-1/2 inch Dia. Splined 17T with 40,3 [1.59] Min. Full Spline Length and 3/8-16 Threaded Hole

**10**..... 40 mm Dia. Straight with Straight Key, M12 x 1,75-6H Threaded Hole

**21**..... 50 mm Dia. Straight with Straight Key, 14W x 9H x 70L, M12 x 1,75-6H Thread in End (Available with Mounting Flange Code H Only)

**24**..... 60 mm Dia. 10:1 Tapered Shaft with M42 x 3-6H Threaded End (Available with Mounting Flange Code H Only)

**25**..... 2 1/8 inch Dia. Splined 16 Tooth, 55,9 mm [2.20] Min. Full Spline Length (Available with Mounting Flange Code H Only)

**Position 9 Port Type**

**A**..... 1-5/16 - 12 O-ring with 7/16-20 O-ring Case Drain and Check Valve

**B**..... 3/4 inch 4 Bolt Split Flange with 7/16-20 O-ring Case Drain and Check Valve

**C**..... G 1 (BSP) O-ring with G 1/4 (BSP) O-ring Case Drain and Check Valve

**D**..... 1- 5/16-12 O-ring with (2) 9/16-18 O-ring Case Drain Ports and Hot Oil Shuttle Valve

**R**..... 1- 5/16-12 O-ring with (2) 9/16-18 O-ring Ports for External Lubrication Circuit (both case ports must be connected)

**Position 10, 11 Special Features (Hardware)**

**00**..... None

**10**..... Viton Shaft Seal

**07**..... Viton Seals

**13**..... Reverse Rotation

**14**..... Seal Guard

**21**..... Speed Sensor (Std.)

**Position 12 Paint/Special Packaging**

**0**..... No Paint

**A**..... Painted Low Gloss Black

**B**..... Corrosion Protected

**Position 13 Eaton Assigned Code when Applicable**

**0**..... Assigned Code

**Position 14 Eaton Assigned Design Code**

**0**..... Assigned Design Code

## Specifications 10,000 Series

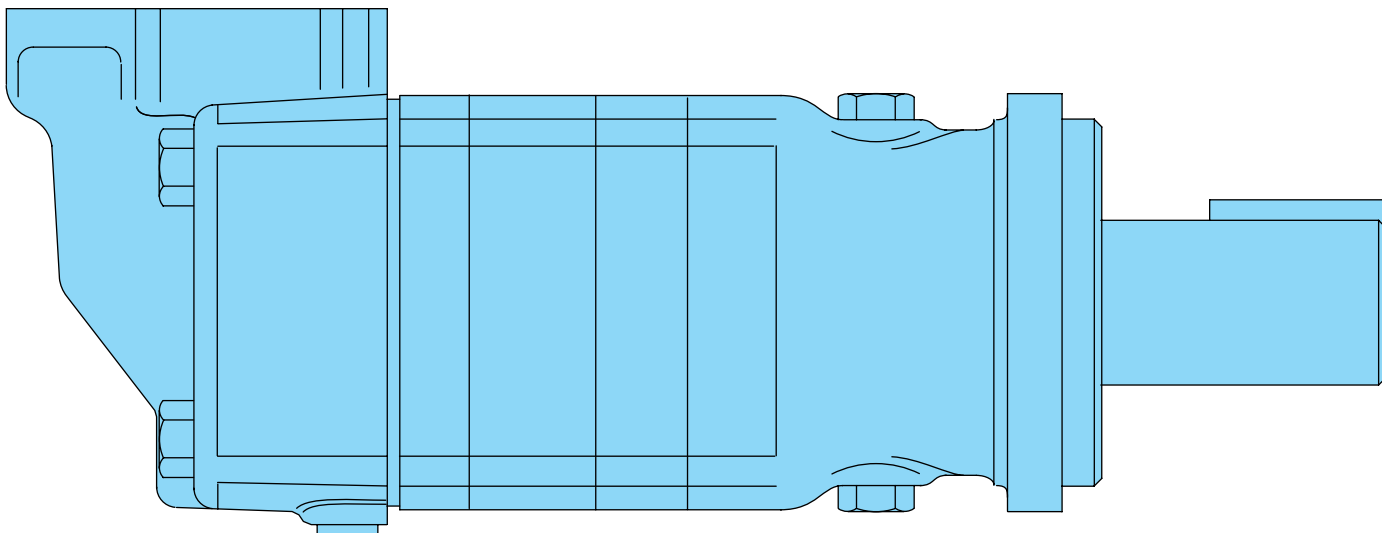

### Specification Data—10,000 Series

Displ. cm <sup>3</sup> /r [in <sup>3</sup> /r]		345 [21.0]	480 [29.3]	665 [40.6]	940 [57.4]
Max. Speed (RPM) @ ..... Flow	Continuous	501	354	254	179
	Intermittent	784	552	396	279
Flow LPM [GPM]	Continuous	170 [45]	170 [45]	170 [45]	170 [45]
	Intermittent	265 [70]	265 [70]	265 [70]	265 [70]
Torque Nm [lb-in]	Continuous	1040 [ 9220]	1475 [13050]	2085 [18450]	2700 [23910]
	Intermittent	1390 [12310]	1965 [17410]	2610 [23080]	3440 [30460]
Pressure Δ Bar [Δ PSI]	Continuous	205 [3000]	205 [3000]	205 [3000]	190 [2750]
	Intermittent	275 [4000]	275 [4000]	260 [3750]	240 [3500]
	Peak	275 [4000]	275 [4000]	275 [4000]	260 [3750]

Maximum Case Pressure - without Case Drain \* — 20 Bar [300 PSI]

**A simultaneous maximum torque and maximum speed NOT recommended.** For permissible continuous and intermittent operating combinations of pressure and flow refer to performance data on pages 65-66.

\* For back pressure over 20 Bar [300 PSI] use an external case drain. Install case drain lines so that the motor case remains filled at all times.

**Maximum inlet pressure** — 275 Bar [4000 PSI]. Do not exceed Δ pressure rating (see chart above).

\* **Maximum return pressure** — 275 Bar [4000 PSI]. Do not exceed Δ pressure rating (see chart above).

Δ Bar [Δ PSI] — True pressure difference between inlet port and outlet port.

**Continuous Rating** — Motor may be run continuously at these ratings.

**Intermittent Operation** — 10% of every minute.

**Peak Operation** — 1% of every minute.

**Recommended Fluids** — Premium quality, anti-wear type hydraulic oil with a viscosity of not less than 70 SUS at operating temperature (see page 81).

**Recommended Maximum System Operating Temp.** — Is 82° C [180° F]

**Recommended Filtration** — per ISO Cleanliness Code, level 18/13

To assure best motor life, run motor for approximately one hour at 30% of rated pressure before application to full load. Be sure motor is filled with fluid prior to any load applications.



# Performance Data 10,000 Series

Motors run with high efficiency in all areas designated with a number for torque and speed, however for best motor life select a motor to run with a torque and speed range shown in the light blue area.

345 cm<sup>3</sup>/r [21.0 in<sup>3</sup>/r]  
Δ Pressure Bar [PSI]

480 cm<sup>3</sup>/r [29.3 in<sup>3</sup>/r]  
Δ Pressure Bar [PSI]

	[250] 15	[500] 35	[1000] 70	[1500] 105	[2000] 140	[2500] 170	[3000] 205	[3500] 240	[4000] 275
[1] 3.8	[600] 70 3	[1310] 150 1							
[2] 7.5	[740] 85 21	[1510] 170 19	[3050] 345 15	[4600] 520 11	[6140] 695 8	[7680] 865 4			
[4] 15	[730] 80 43	[1500] 170 41	[3040] 345 37	[4590] 520 33	[6140] 695 30	[7680] 870 26	[9220] 1040 22	[10770] 1215 18	[12310] 1390 14
[8] 30	[720] 80 87	[1490] 170 86	[3030] 340 82	[4580] 515 74	[6120] 690 70	[7670] 865 70	[9210] 1040 66	[10750] 1215 62	[12300] 1390 58
[12] 45	[700] 80 131	[1470] 165 129	[3020] 340 127	[4560] 515 123	[6100] 690 118	[7650] 865 114	[9190] 1040 110	[10740] 1215 106	[12280] 1385 102
[16] 61	[680] 75 175	[1450] 165 174	[3000] 340 172	[4540] 515 167	[6080] 685 163	[7630] 860 158	[9170] 1035 154	[10720] 1210 149	[12260] 1385 145
[20] 76	[660] 75 219	[1430] 160 218	[2970] 335 217	[4520] 510 212	[6060] 685 207	[7600] 860 202	[9150] 1035 198	[10690] 1210 193	[12230] 1380 189
[24] 91	[630] 70 263	[1400] 160 262	[2950] 335 261	[4490] 505 256	[6030] 680 252	[7580] 855 246	[9120] 1030 242	[10660] 1205 237	[12210] 1380 232
[28] 106	[600] 70 307	[1370] 155 306	[2920] 330 305	[4460] 505 301	[6000] 680 296	[7550] 855 291	[9090] 1025 286	[10640] 1200 280	[12180] 1375 275
[32] 121	[570] 65 351	[1340] 150 350	[2890] 325 349	[4430] 500 345	[5970] 675 340	[7520] 850 335	[9060] 1025 329	[10610] 1200 324	[12150] 1370 319
[36] 136	[540] 60 395	[1310] 150 394	[2850] 320 393	[4400] 495 388	[5940] 670 384	[7480] 845 379	[9030] 1020 373	[10570] 1195 368	[12120] 1370 362
[40] 151	[500] 55 439	[1270] 145 438	[2820] 320 437	[4360] 495 433	[5910] 670 429	[7450] 840 423	[8990] 1015 417	[10540] 1190 412	
[45] 170	[460] 50 494	[1220] 140 493	[2760] 310 492	[4300] 485 490	[5840] 660 486	[7380] 835 480	[8910] 1005 473	[10450] 1180 467	
[60] 227		[1080] 130 659	[2620] 295 658	[4160] 470 655	[5710] 645 651	[7250] 820 644	[8800] 995 637		
[70] 265		[960] 110 769	[2510] 285 768	[4050] 460 765	[5590] 630 761	[7140] 805 754	[8680] 980 746		

	[250] 15	[500] 35	[1000] 70	[1500] 105	[2000] 140	[2500] 170	[3000] 205	[3500] 240	[4000] 275
[1] 3.8	[760] 85 6	[1540] 175 5	[3120] 355 4	[4640] 525 2					
[2] 7.5	[1040] 120 15	[2140] 240 13	[4320] 490 11	[6500] 735 8	[8690] 980 5	[10870] 1230 2			
[4] 15	[1040] 120 31	[2130] 240 29	[4310] 485 27	[6490] 735 24	[8680] 980 21	[10860] 1225 18	[13050] 1475 16	[15230] 1720 13	[17410] 1965 10
[8] 30	[1020] 115 87	[2110] 240 86	[4290] 485 82	[6480] 730 74	[8680] 980 53	[10840] 1225 50	[13030] 1470 47	[15210] 1720 44	[17390] 1965 42
[12] 45	[990] 110 94	[2080] 235 93	[4270] 480 90	[6450] 730 87	[8660] 975 81	[10820] 1220 81	[13000] 1470 78	[15180] 1715 75	[17370] 1965 73
[16] 61	[960] 110 125	[2060] 235 124	[4240] 480 122	[6420] 725 119	[8600] 970 116	[10790] 1220 113	[12970] 1465 110	[15150] 1710 107	[17340] 1960 104
[20] 76	[930] 105 156	[2020] 230 155	[4200] 475 154	[6390] 720 150	[8570] 970 147	[10750] 1215 144	[12940] 1460 141	[15120] 1710 138	[17300] 1955 135
[24] 91	[890] 100 188	[1980] 225 187	[4170] 470 185	[6350] 715 182	[8530] 965 179	[10720] 1210 175	[12900] 1460 172	[15080] 1705 169	
[28] 106	[850] 95 220	[1940] 220 219	[4130] 465 217	[6310] 715 214	[8490] 960 210	[10680] 1205 207	[12860] 1455 203	[15040] 1700 200	
[32] 121	[810] 90 251	[1900] 215 250	[4080] 460 249	[6270] 710 245	[8450] 955 242	[10630] 1200 238	[12820] 1450 235	[15000] 1695 231	
[36] 136	[760] 85 283	[1850] 210 282	[4040] 455 280	[6220] 705 277	[8400] 950 273	[10590] 1195 270	[12770] 1445 266		
[40] 151	[710] 80 314	[1800] 205 313	[3990] 450 312	[6170] 695 308	[8350] 945 305	[10540] 1190 301	[12720] 1440 297		
[45] 170	[647] 75 354	[1740] 195 353	[3920] 445 351	[6110] 690 348	[8290] 935 344	[10470] 1185 340	[12660] 1430 336		
[60] 227		[430] 50 472	[1520] 170 471	[3710] 420 469	[5890] 665 467	[8070] 910 462	[10260] 1160 458	[12440] 1405 454	
[70] 265			[1360] 155 551	[3540] 400 550	[5730] 645 546	[7910] 895 541	[10100] 1140 536	[12280] 1385 532	

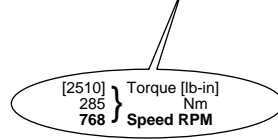

Light blue background: Continuous  
Dark blue background: Intermittent

Performance data is typical at 120 SUS. Actual data may vary slightly from unit to unit in production



# Dimensions — 10,000 Series Standard Motor

Shaft Dim. See Page 71

2-1/4 Inch Dia. Straight Shaft or  
2-1/4 Inch Dia. Tapered Shaft

2-1/8 Inch Dia. Splined Shaft

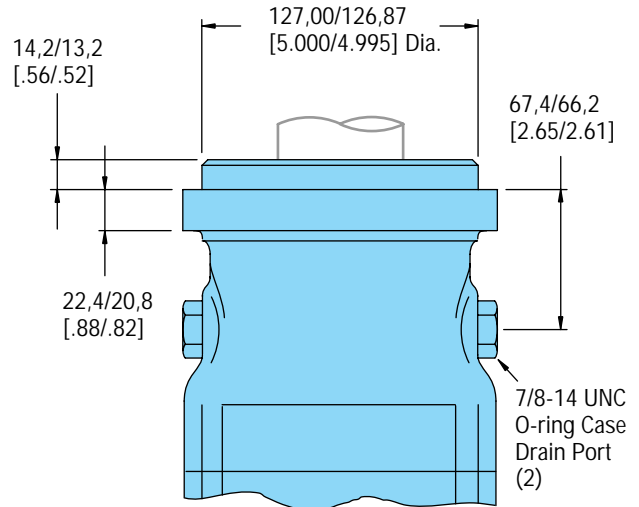
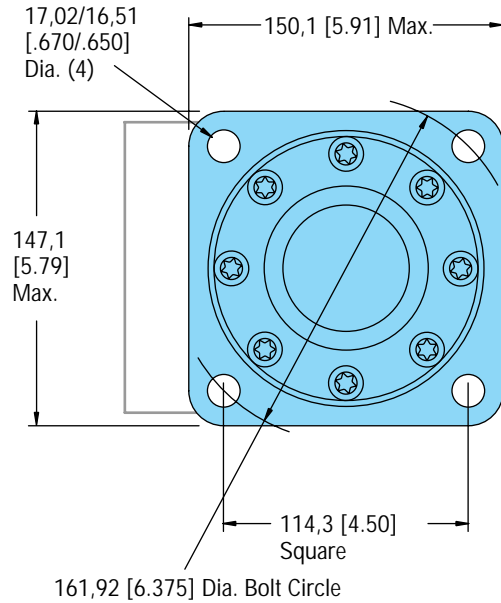
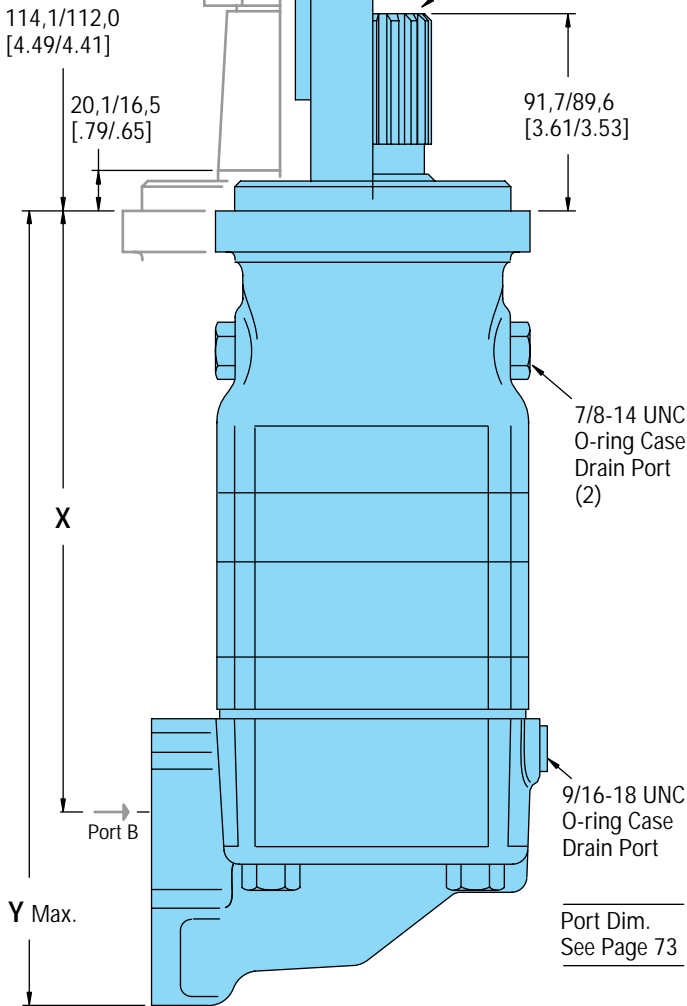

Port Dim.  
See Page 73

## 10,000 Series Standard Motor

Displ. cm <sup>3</sup> /r [in <sup>3</sup> /r]	345 [21.0]	480 [29.2]	665 [40.6]	940 [57.4]
X Dim. mm [inch]	282,4 [11.12]	295,1 [11.62]	295,1 [11.62]	313,4 [12.34]
Y Dim. mm [inch]	381,0 [15.00]	393,7 [15.50]	393,7 [15.50]	412,0 [16.22]

### Standard Rotation

Viewed from Shaft End  
Port A Pressurized — CW  
Port B Pressurized — CCW

# Dimensions — 10,000 Series Wheel Motor

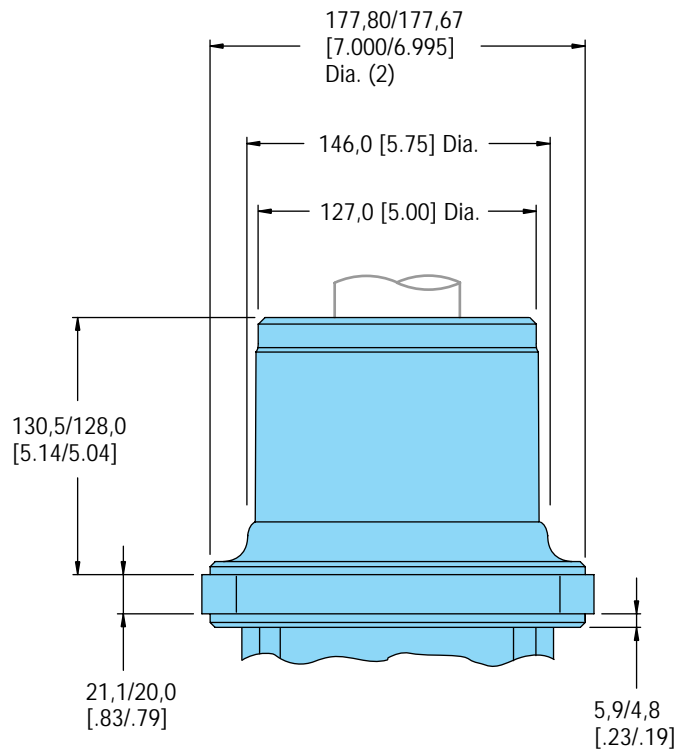
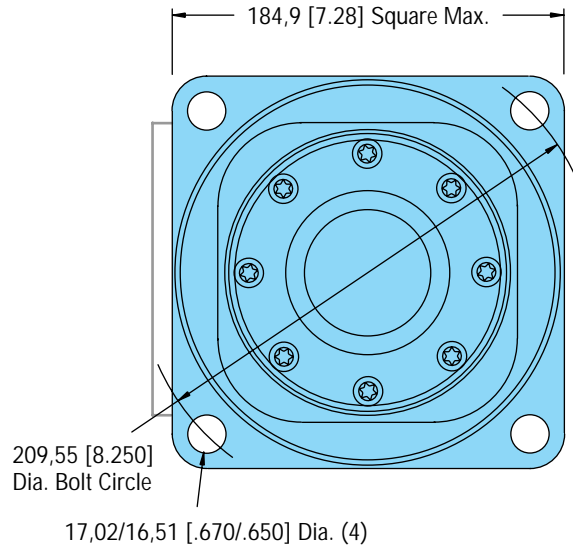
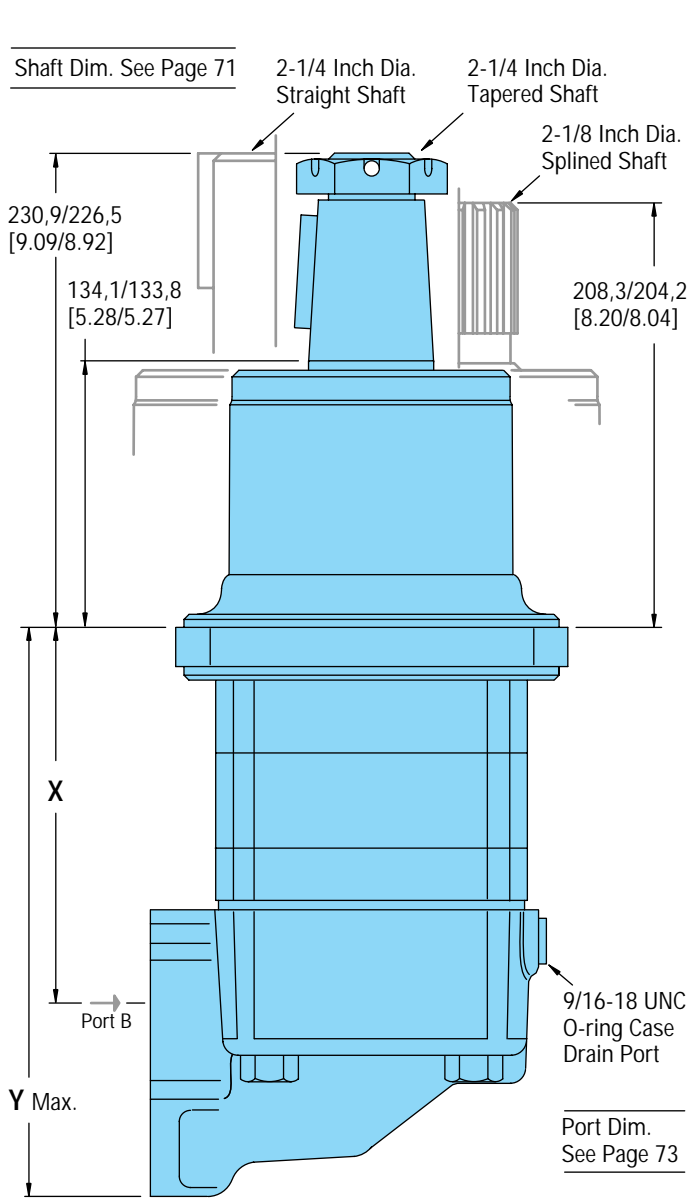

## 10,000 Series Wheel Motor

Displ. cm <sup>3</sup> /r [in <sup>3</sup> /r]	345 [21.0]	480 [29.2]	665 [40.6]	940 [57.4]
X Dim. mm [inch]	166,9 [6.57]	179,6 [7.07]	179,6 [7.07]	197,8 [7.79]
Y Dim. mm [inch]	266,2 [10.48]	278,9 [10.98]	278,9 [10.98]	297,5 [11.71]

**Standard Rotation**  
Viewed from Shaft End  
Port A Pressurized — CW  
Port B Pressurized — CCW

# Dimensions — 10,000 Series Bearingless Motor

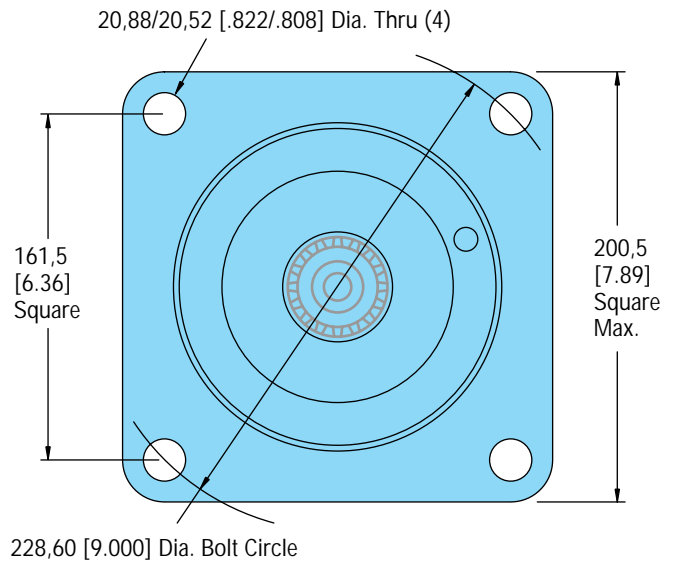

**Standard Rotation**  
Viewed from Drive End  
Port A Pressurized — CW  
Port B Pressurized — CCW

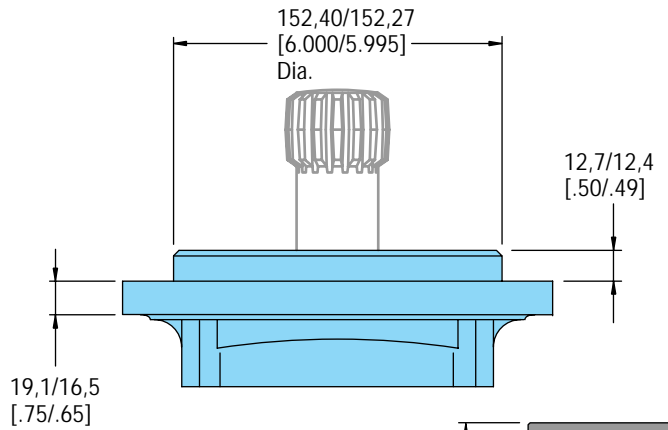
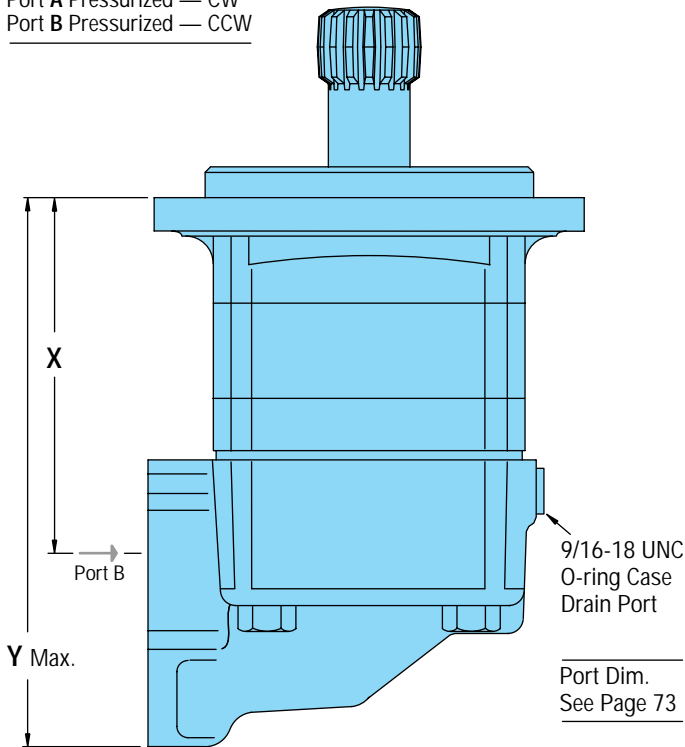

For 10,000 Series bearingless motor application information contact your Eaton representative (mating coupling blanks available from Eaton Corporation). Note: After machining blank, part must be hardened per Eaton specification.

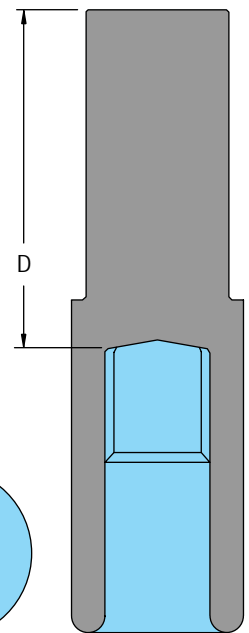

## 10,000 Series Bearingless Motor

Displ. cm <sup>3</sup> /r [in <sup>3</sup> /r]	345 [21.0]	480 [29.2]	665 [40.6]	940 [57.4]
X Dim. mm [inch]	189,5 [7.46]	202,2 [7.96]	202,2 [7.96]	221,0 [8.70]
Y Dim. mm [inch]	288,5 [11.36]	301,0 [11.85]	301,0 [11.85]	319,5 [12.58]

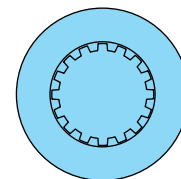

Mating Coupling Blank Eaton Part No. 13280-001	Dimension D mm [inch]
13280-001	133,6/128,5 [5.26/5.06]
13280-002	156,0/150,9 [6.14/5.94]

# Bearingless Installation — 10,000 Series

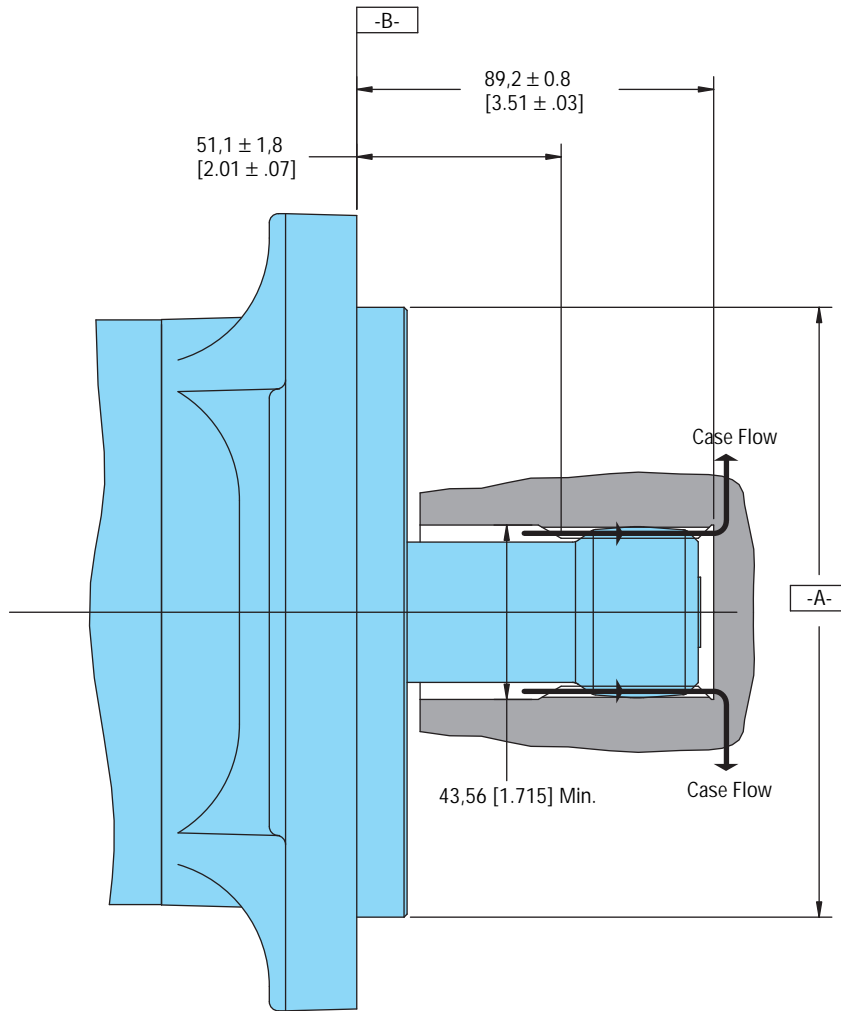

- Spline Pitch — 10/20
- Pressure Angle — 30°
- Number of teeth — 16
- Class of Fit — Ref. 5
- Type of Fit — Side
- Pitch Diameter — Ref. 40,640000 [1.600000] ◎ 0,25 [0.10] D
- Base Diameter — Ref. 35,195272 [1.3856406]
- Major Diameter — 43,56 [1.715] Max. 43,18 [1.700] Min.
- Minor Diameter — 36,83 - 37,08 [1.450 - 1.460]
- Form Diameter, Min. — 42,47 [1.672]
- Fillet Radius — 0,64 - 0,76 [.025 - .030]
- Tip Radius — 0,25 - 0,51 [.010 - .020]
- Finish — 1,6 [63]
- Involute Profile Variation — +0,000 -0,028 [+0.0000 -0.0011]
- Total Index Variation — 0,041 [.0016]
- Lead Variation — 0,013 [.0005]
- Circular Space Width:
  - Maximum Actual — 4,105 [.1616]
  - Minimum Effective — 3,995 [.1573]
  - Maximum Effective — Ref. 4,056 [.1597]
  - Minimum Actual — Ref. 4,018 [.1582]
- Dimension Between Two Pins — Ref. 34,272 - 34,450 [1.3493 - 1.3563]

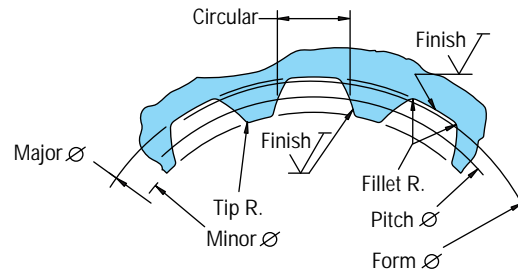

- 1 Internal spline in mating part to be as follows:  
 Material to be ASTM A304, 8620H.  
 Carborize to a hardness of 58-64 HRC with case depth (to 50HRC) of 0,076 - 1,02 [.030 - .040] (dimensions apply after heat treat).

# Dimensions — Shafts

## 10,000 Series

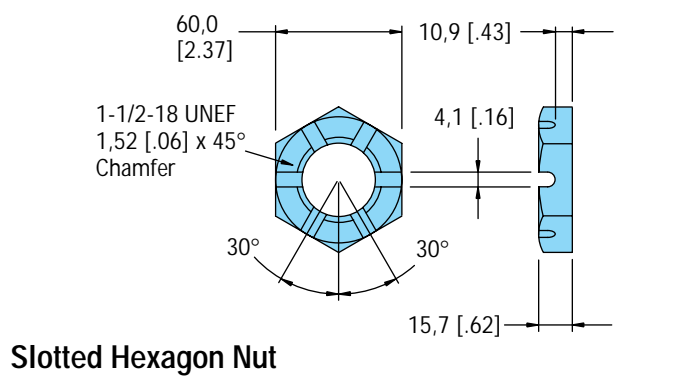
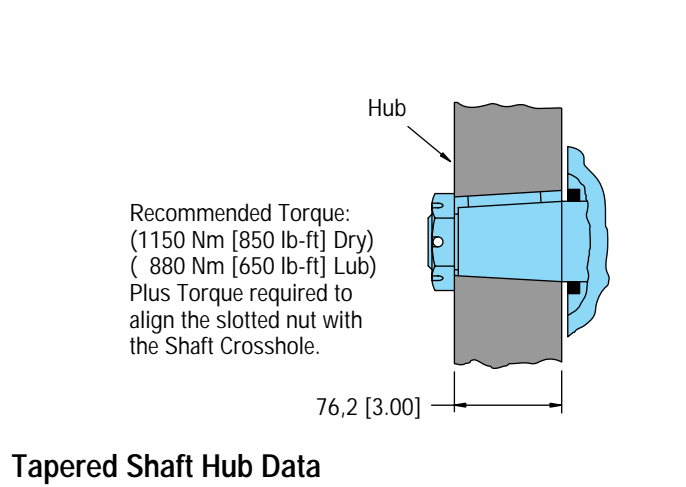
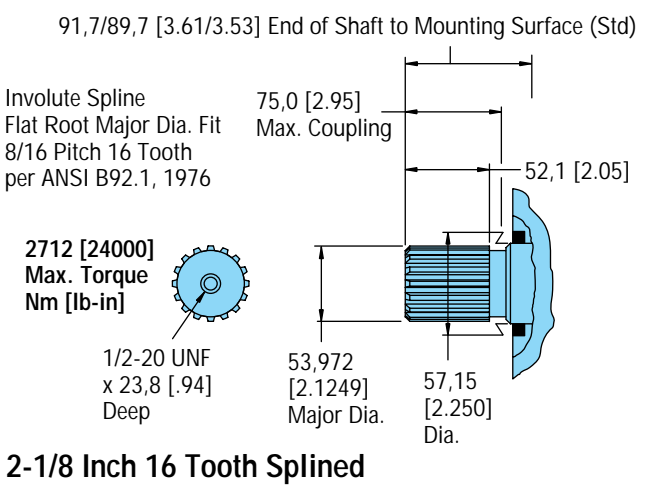
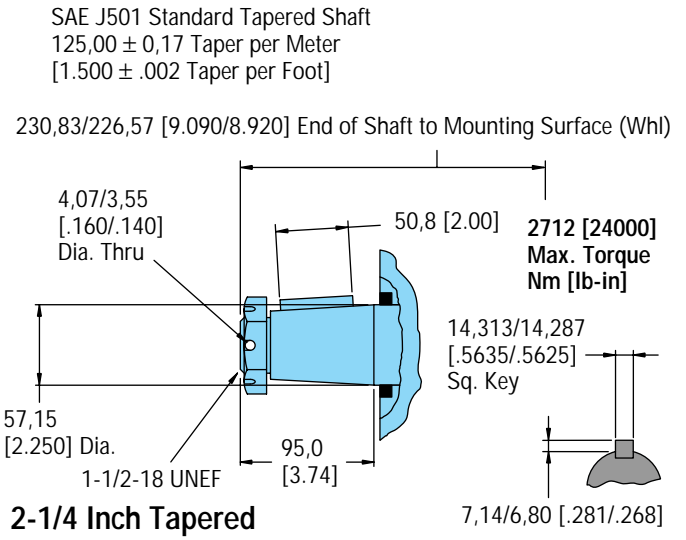
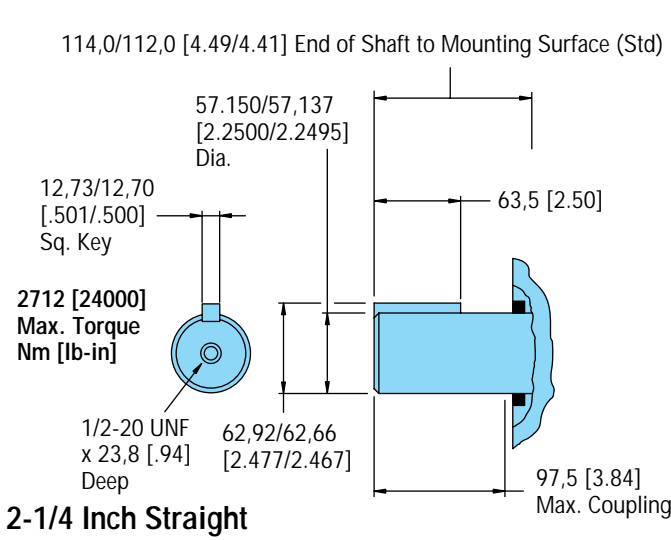

# Shaft Side Load Capacity 10,000 Series

This curve indicates the radial load capacity on the motor shaft(s) at various locations.

The curve is based on B 10 Bearing life (2000 hours or 12,000,000 shaft revolutions at 100 RPM) at rated output torque. To determine radial load at speeds other than 100 RPM, multiply the load values given on the bearing curve by the factors in the chart below.

RPM	Multiplication Factor
50	1.23
100	1.00
200	.81
300	.72
400	.66
500	.62
600	.58
700	.56
800	.54

For 3,000,000 Shaft revolutions or 500 hours — Increase these shaft loads 52%.

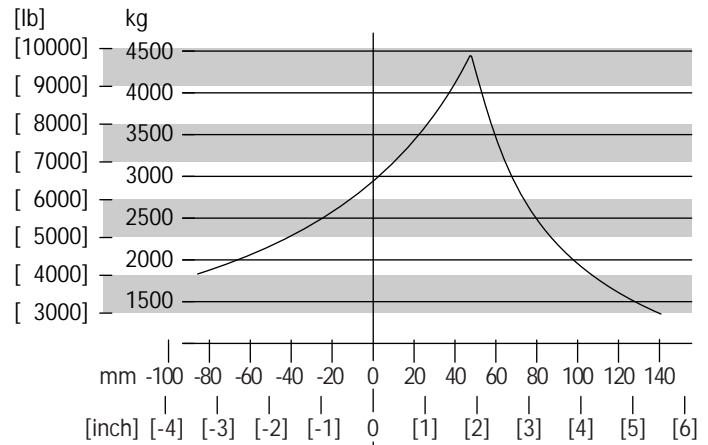

Standard Motor

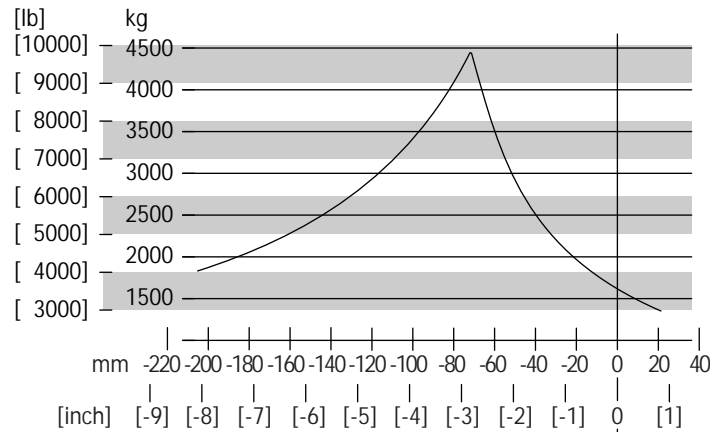
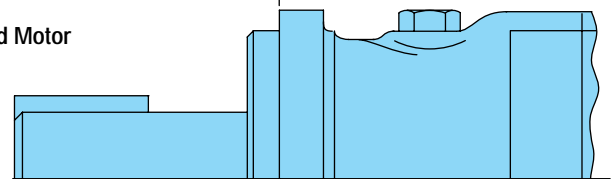

Wheel Motor

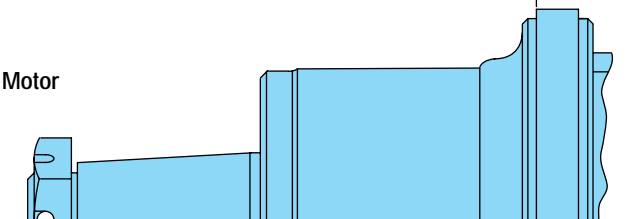



# Dimensions — Ports 10,000 Series

## 1-1/4 Inch Split Flange Ports (2)

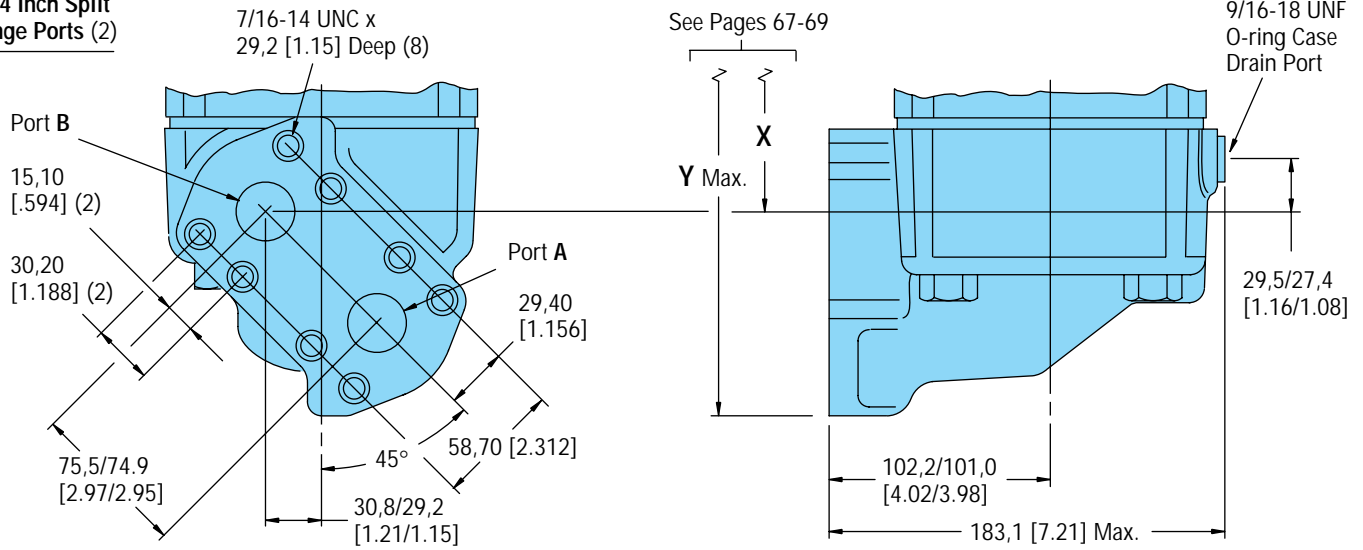

## 1-5/16 -12 O-ring Ports (2)

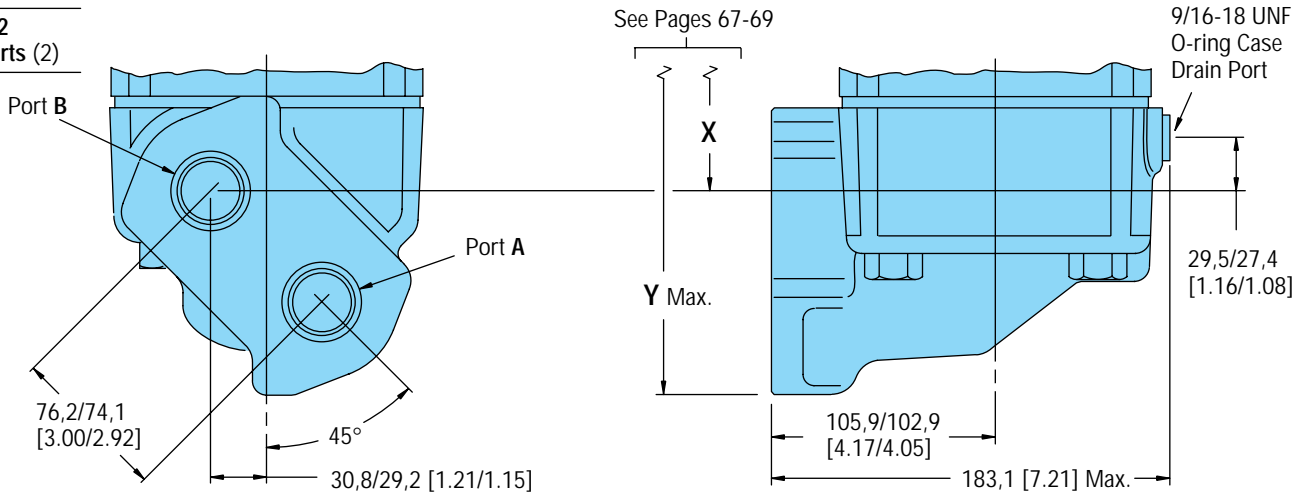

## 10,000 Series Motor End View—Common Dim.

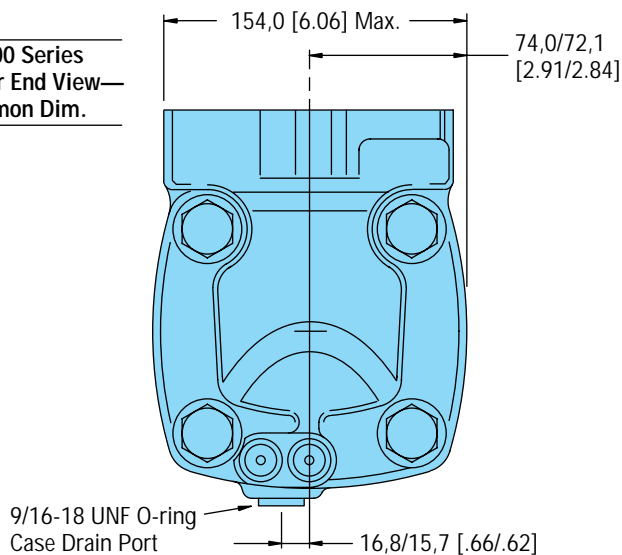

**Standard Rotation 10,000 Series**  
 Viewed from Shaft End  
 Port A Pressurized — CW  
 Port B Pressurized — CCW

# Product Numbers 10,000 Series

## Product Numbers—10,000 Series Motors

Use digit prefix —119-, 120-, or 121- plus four digit number from charts for complete product number—Example 121-1014.  
Orders will not be accepted without three digit prefix.

Mounting	Shaft	Ports	Displacement cm <sup>3</sup> /r [ in <sup>3</sup> /r ] and Product Number				
			345 [21.0]	480 [29.3]	665 [40.6]	940 [57.4]	
Standard	2-1/4 inch Straight	1-5/16 O-ring	119-1028	-1029	-1030	-1031	
		1-1/4 Split Flange	119-1040	-1041	-1042	-1043	
	2-1/8 Inch 16 T Splined	1-5/16 O-ring	119-1032	-1033	-1034	-1035	
		1-1/4 Split Flange	119-1044	-1045	-1046	-1047	
	2-1/4 Inch Tapered	1-5/16 O-ring	119-1036	-1037	-1038	-1039	
		1-1/4 Split Flange	119-1048	-1049	-1050	-1051	
	Wheel Motor	2-1/4 inch Straight	1-5/16 O-ring	120-1005	-1006	-1007	-1008
			1-1/4 Split Flange	120-1017	-1018	-1019	-1020
2-1/8 Inch 16 T Splined		1-5/16 O-ring	120-1009	-1010	-1011	-1012	
		1-1/4 Split Flange	120-1021	-1022	-1023	-1024	
2-1/4 Inch Tapered		1-5/16 O-ring	120-1013	-1014	-1015	-1016	
		1-1/4 Split Flange	120-1025	-1026	-1027	-1028	
Bearingless			1-5/16 O-ring	121-1007	-1008	-1009	-1010
			1-1/4 Split Flange	121-1011	-1012	-1013	-1014

121-1014

For 10,000 Series motors with a configuration *Not Shown* in the charts above: Contact your Eaton representative.

## Model Code for 10,000 Series Motors

The following 14-digit coding system has been developed to identify all of the configuration options for the 10000 Series Motor. Use this model code to specify a motor with the desired features. All 14-digits of the code must be present when ordering. You may want to photocopy the matrix below to ensure that each number is entered in the correct box.

### Model Code — 10,000 Series Disc Valve Motors

1	2	3	4	5	6	7	8	9	10	11	12	13	14
M	1	0										0	0

**Position 1 Product Series**

**M** ..... Motor

**Position 2, 3 10 000 Series**

**10** ..... 10 000 Series

**Position 4, 5 Displacement cm<sup>3</sup>/r [in<sup>3</sup>/r]**

**20** ..... 345 [21.0]

**29** ..... 480 [29.2]

**40** ..... 665 [40.6]

**57** ..... 940 [57.4]

**Position 6 Mounting Flange**

**A** ..... 4 Bolt (Std.): Dia. 127,0 [5.00] Pilot 16,76 [.660]  
Mounting Holes on 161,92 [6.375] Dia. Bolt Circle

**B** ..... 4 Bolt (Whl.): Dia. 177,8 [7.00] Pilot 16,76 [.660]  
Mounting Holes on 209,55 [8.250] Dia. Bolt Circle

**C** ..... 4 Bolt (Brgl.): Dia. 152,4 [6.00] Pilot 20,70[.815]  
Mounting Holes on 228,60 [9.000] Dia. Bolt Circle

**Position 7, 8 Output Shaft**

**01** ..... 2-1/4 inch Dia. Straight with 12,7 [.50] Square Key x  
63,5 [2.50] and 1/2 - 20 Threaded Hole

**02** ..... 2-1/4 inch Dia. Tapered with 14,3 [.56] Square Key x  
50,8 [2.00] and 1-1/2 - 18 UNEF-2A Threaded Shaft  
End and Slotted Hex Nut

**03** ..... 2-1/8 inch 16 Tooth Splined with 52,1 [2.05] Min.  
Full Spline Length 1/2 - 20 UNF Threaded Hole

**Position 9 Port Type**

**A** ..... 1-5/16—12 UN O-ring End Ports (Size -16), 9/16-18  
UNF O-ring Case Drain Port (Size -6)

**B** ..... 1-1/4 Inch Split Flange Ports, 9/16 - 18 UNF O-ring  
Case Drain Port (Size -6)

**Position 10, 11 Special Features (Hardware)**

**00** ..... None

**01** ..... Free Running Geroler

**03** ..... Reverse Rotation

**Position 12 Paint/Special Packaging**

**0** ..... No Paint

**A** ..... Painted Low Gloss Black

**Position 13 Eaton Assigned Code when Applicable**

**0** ..... Assigned Code

**Position 14 Eaton Assigned Design Code**

**0** ..... Assigned Design Code

## Two Speed Motor — 10,000 Series

The Eaton 10,000 Series motors are available with an integral two speed feature that changes the displacement in a ratio of 1 to 2 and shifts the motor from a low speed high torque (LSHT) mode to a high speed low torque (HSLT) mode. The open center selector valve shifts the speed mode from low to high speed when pilot pressure of 6.9 Bar [100 Δ PSI] minimum is applied to the pilot port (6.9 Bar [100 PSI] higher than case pressure). In the high speed mode torque values are approximately one half with twice the speed of the conventional 10,000 Series single speed motors.

An external two position three way valve is required for shifting the pilot pressure port between signal pressure (HSLT) and low pressure (LSHT)

Two speed motors are available with a return line closed center shuttle for closed circuit applications.

Low speed high torque mode is the normal position of the speed selector valve. When a differential pressure is supplied to the pilot port and 6,9 Bar [100 PSI] is reached, the selector valve overcomes the return spring force and the spool shifts to the high speed mode. The oil in the opposite side of the spool is drained internally. Pressure between the pilot supply and case drain or return line (depending on open or closed circuit system) must be maintained to keep the motor in the high speed mode.

When pilot pressure is removed from the pilot port the pressure in the pilot end of the spool valve is relieved and drained back through this three way valve, the spring force returns the spool valve to LSHT position.

Pilot pressure may come from any source that will provide uninterrupted pressure during the high speed mode operation. Pilot pressure 6,9 Bar [100 Δ PSI] minimum, up to the full operating pressure of the motor.

In normal LSHT operation the Char-Lynn two speed motor will function with equal shaft output in either direction (CW or CCW), the same as the single speed Char-Lynn disc valve motors.

However, to prevent cavitation in the HSLT mode, the preferred direction of shaft rotation is counter clockwise (port B pressurized). This unique disc valve is not symmetrical in porting the fluid for the HSLT mode. Consequently, when the pressure is reversed for HSLT CW rotation, cavitation can occur. Installing a restriction (14 - 34 Bar [200 - 500 PSI]) in the hydraulic line that connects port B will prevent cavitation (see page 75).

If you are operating in a critical area and a restriction in the hydraulic line causes concern, these two speed motors can be ordered timed with CW preferred HSLT shaft rotation. Hence, with this option port B will have to be pressurized for CW preferred HSLT shaft rotation. The restriction recommended for the line connecting port B remains unchanged. Finally in closed circuit applications a hydraulic line restriction is not required. Instead, the charge pump can be used to supply and maintain a minimum pressure of 14 Bar [200 PSI].

**Note:** Be certain in closed loop applications that the charge pump when used for back pressure on the B port, has sufficient displacement to maintain charge pressure especially in dynamic braking or overrunning load conditions.

**Important!** Due to potential problems in maintaining charge pump pressure at port B for uninterrupted back pressure during dynamic braking, Eaton does not recommend the two speed motor where overrunning conditions may exist.

## Performance Data Two Speed Motor — 10,000 Series

In the high speed mode torque values are approximately one half with twice the speed of the conventional 10,000 Series single speed motors. In the low speed mode torque and speed values are the same as the conventional

# Two Speed Motor — 10,000 Series

Pump Pressure and Return, and  
Shaft Rotation Directional Control Valve

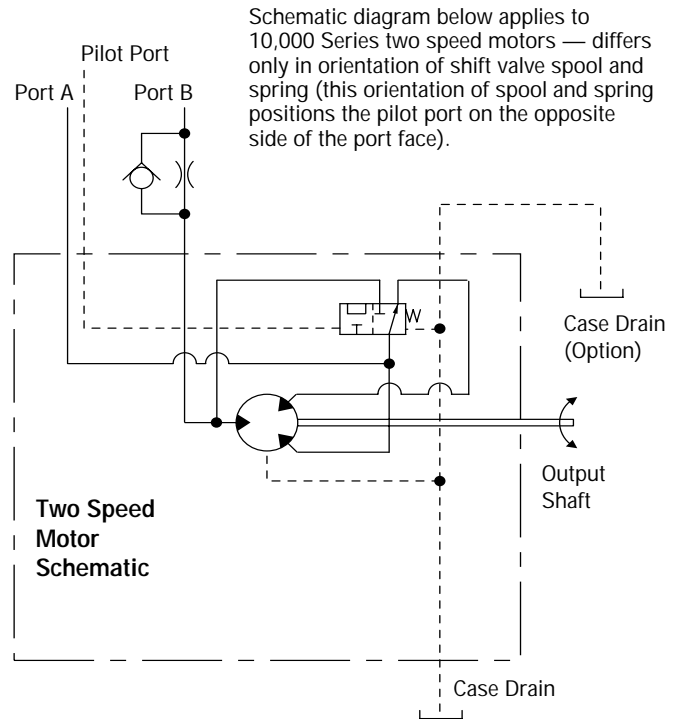
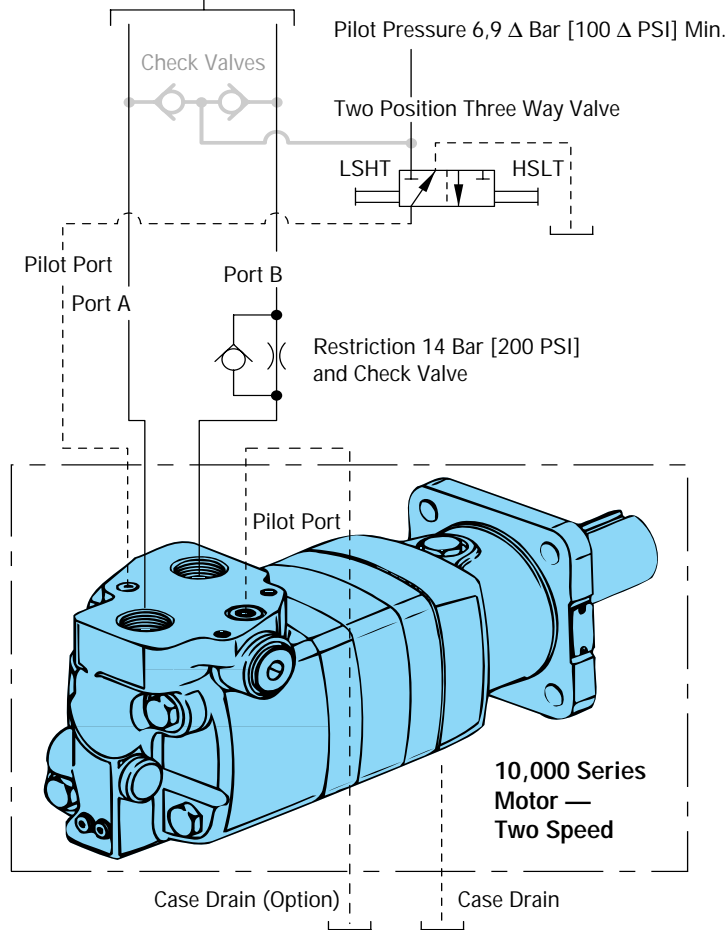

Schematic diagram below applies to 10,000 Series two speed motors — differs only in orientation of shift valve spool and spring (this orientation of spool and spring positions the pilot port on the opposite side of the port face).

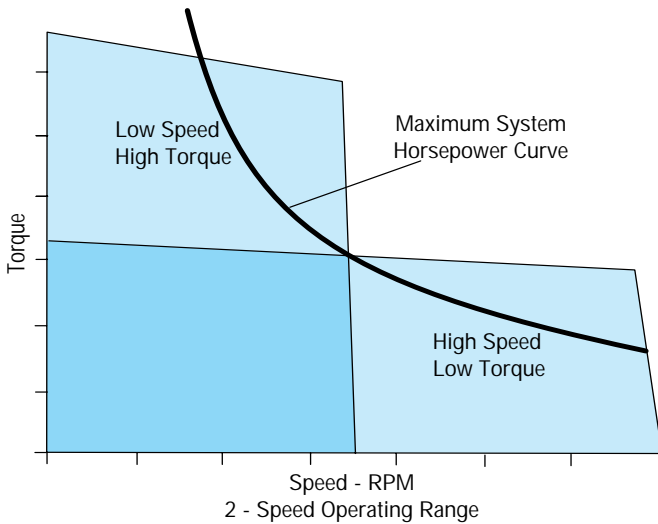

# Specifications — Two Speed 10,000 Series

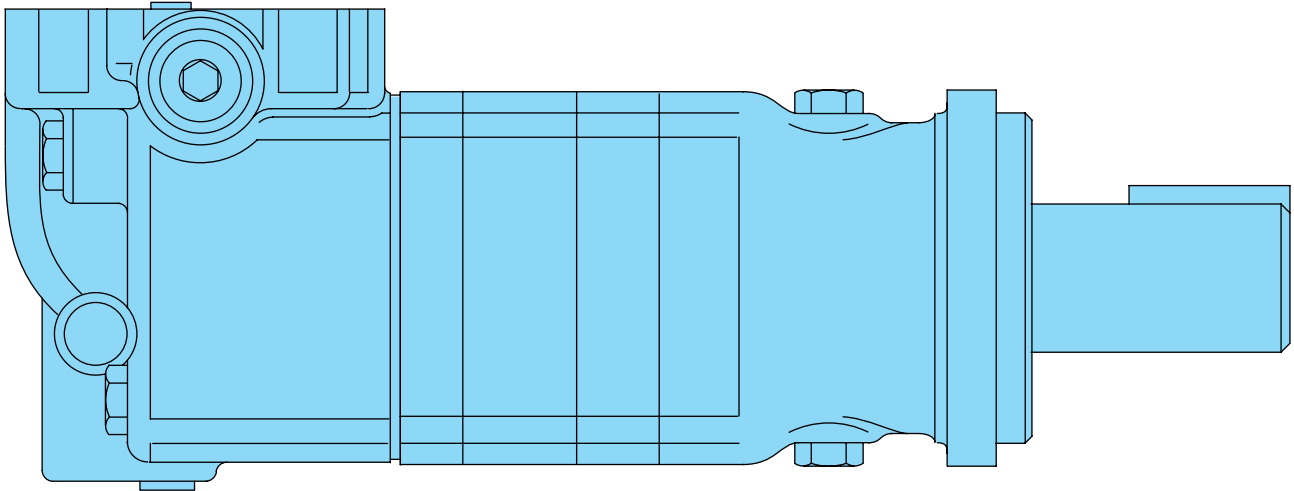

## Specification Data—10,000 Series Two Speed

Displ. cm <sup>3</sup> /r. [in <sup>3</sup> /r]	High Speed Mode		169 [10.3]	239 [14.6]	332.7 [20.3]	470 [28.7]
	Low Speed Mode		345 [21.0]	480 [29.3]	665 [40.6]	940 [57.4]
Max. Speed (RPM) @ Continuous Flow	High Speed Mode		750	630	500	400
	Low Speed Mode		375	315	250	200
Flow LPM [GPM]	High Speed Mode		130 [35]	170 [45]	170 [45]	170 [45]
	Low Speed Mode		130 [35]	170 [45]	170 [45]	170 [45]
Torque Nm [lb-in]	High Speed Mode	Continuous	440 [ 3900]	630 [ 5600]	905 [ 8000]	1175 [10400]
		Intermittent	585 [ 5200]	845 [ 7500]	1130 [10000]	1470 [13000]
Torque Nm [lb-in]	Low Speed Mode	Continuous	1015 [ 9000]	1470 [13000]	2090 [18500]	2710 [24000]
		Intermittent	1355 [12000]	1965 [17400]	2600 [23000]	3445 [30500]
Pressure Δ Bar [Δ PSI]	Continuous		205 [3000]	205 [3000]	205 [3000]	190 [2750]
	Intermittent		275 [4000]	275 [4000]	260 [3750]	240 [3500]

Maximum Case Pressure - without Case Drain \* — 20 Bar [300 PSI]

### High Speed Mode (Reduced Motor Displacement)

### Low Speed Mode (Full Motor Displacement)

Maximum torque and flow must not occur simultaneously. For permissible continuous and intermittent operating combinations of pressure and flow refer to performance data on pages 65-66 (LSHT only).

\* For back pressure over 20 Bar [300 PSI] use an external case drain. Install case drain lines so that the motor case remains filled at all times.

**Maximum inlet pressure** — 275 Bar [4000 PSI]. Do not exceed Δ pressure rating (see chart above).

\* **Maximum return pressure** — 275 Bar [4000 PSI]. Do not exceed Δ pressure rating (see chart above).

**Δ Bar [Δ PSI]** — True pressure difference between inlet port and outlet port.

**Continuous Rating** — Motor may be run continuously at these ratings.

**Intermittent Operation** — 10% of every minute.

**Recommended Fluids** — Premium quality, anti-wear type hydraulic oil with a viscosity of not less than 70 SUS at operating temperature (see page 81).

**Recommended Maximum System Operating Temp.** — Is 82° C [180° F]

**Recommended Filtration** — per ISO Cleanliness Code, level 18/13

To assure best motor life, run motor for approximately one hour at 30% of rated pressure before application to full load. Be sure motor is filled with fluid prior to any load applications.

# Dimensions — Two Speed 10,000 Series Standard, Wheel, and Bearingless

## Two Speed Standard Motor

Displ. cm <sup>3</sup> /r [in <sup>3</sup> /r]	345 [21.0]	480 [29.2]	665 [40.6]	940 [57.4]
X Dim. mm [inch]	270,8 [10.66]	283,5 [11.16]	283,5 [11.16]	301,8 [11.88]
Y Dim. mm [inch]	392,7 [15.46]	405,4 [15.96]	405,4 [15.96]	423,9 [16.69]

## Two Speed Wheel Motor

X Dim. mm [inch]	155,2 [6.11]	167,6 [6.60]	167,6 [6.60]	186,2 [7.33]
Y Dim. mm [inch]	278,1 [10.95]	290,8 [11.45]	290,8 [11.45]	309,1 [12.17]

## Two Speed Bearingless Motor

X Dim. mm [inch]	146,0 [5.75]	159,0 [6.26]	159,0 [6.26]	177,5 [6.99]
Y Dim. mm [inch]	265,5 [10.57]	281,2 [11.07]	281,2 [11.07]	299,5 [11.79]

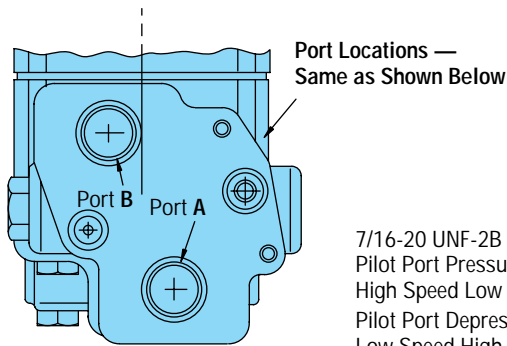
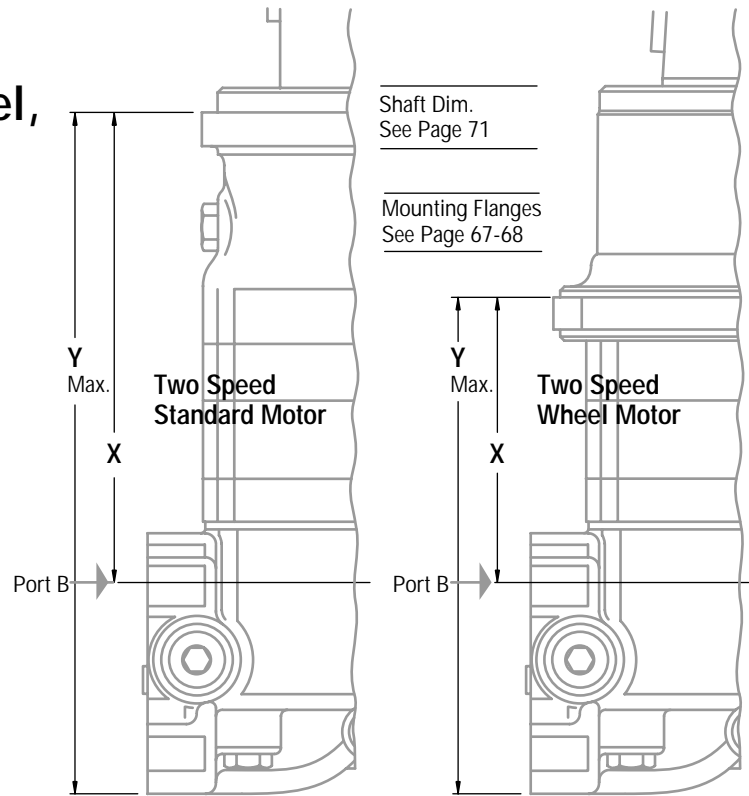

### 1-5/16-12 O-ring Ports (2)

1/2-20 UNF-2B O-ring Case Drain Port Size 5

### 1-1/4 Inch Split Flange Ports (2)

19,6/18,5 [ .77/.73 ]  
39,2/37,0 [ 1.54/1.46 ]  
59,2/58,1 [ 2.33/2.29 ]

7/16-20 UNF-2B O-ring Port — Pilot Control  
Pilot Port Pressurized 6,9 Δ Bar [ 100 Δ PSI ]  
High Speed Low Torque (HSLT)  
Pilot Port Depressurized (Tank)  
Low Speed High Torque (LSHT)

Groove Provided for Seal  
25,38 [ .999 ] OD x 2,41 [ .095 ] Wide  
1,19 [ .047 ] Deep

33,1/31,4 [ 1.30/1.24 ]

71,9/70,3 [ 2.83/2.77 ]

36,1/35,0 [ 1.42/1.38 ]

90,0/87,0 [ 3.54/3.46 ]

3/8-24 UNF-2B x  
15,8 [ .62 ] Min. Deep (2)

14,3/13,2 [ .56/.52 ]

28,2/26,6 [ 1.11/1.05 ]

**Standard Rotation**  
Viewed from Shaft or Drive End  
Port A Pressurized — CW  
Port B Pressurized — CCW

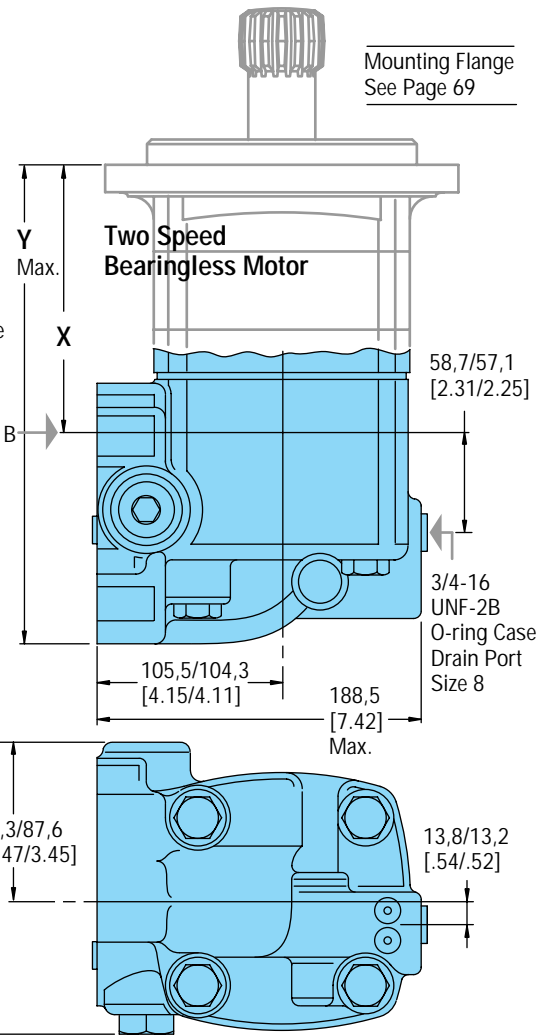

# Product Numbers — Two Speed 10,000 Series

## Product Numbers—10,000 Series Motors—2 Speed

Use digit prefix —119-, 120-, or 121- plus four digit number from charts for complete product number—Example 121-2002.  
Orders will not be accepted without three digit prefix.

Mounting	Shaft	Ports	Displ. cm <sup>3</sup> /r [in <sup>3</sup> /r] Product Number				
			345 [21.0]	480 [29.3]	665 [40.6]	940 [57.4]	
Standard	2-1/4 inch Straight	1-5/16 O-ring	119-2013	-2014	-2015	-2016	
		1-1/4 Split Flange	119-2001	-2002	-2003	-2004	
	2-1/4 Inch Tapered	1-5/16 O-ring	119-2017	-2018	-2019	-2020	
		1-1/4 Split Flange	119-2005	-2006	-2007	-2008	
	2-1/8 Inch 16 T Splined	1-5/16 O-ring	119-2021	-2022	-2023	-2024	
		1-1/4 Split Flange	119-2009	-2010	-2011	-2012	
	Wheel Motor	2-1/4 inch Straight	1-1/4 Split Flange	120-2005	-2006	-2007	-2008
			2-1/4 Inch Tapered	1-5/16 O-ring	120-2013	-2014	-2015
1-1/4 Split Flange		120-2001		-2002	-2003	-2004	
2-1/8 Inch 16 T Splined		1-1/4 Split Flange	120-2009	-2010	-2011	-2012	
		Bearingless	1-5/16 O-ring	121-2005	-2006	-2007	-2008
1-1/4 Split Flange			121-2001	-2002	-2003	-2004	

121-2002

10,000 Series Motors with a configuration *Not Shown* in the charts above: Contact your Eaton Representative.



## Fluid Recommendations

### Char-Lynn Disc Valve Motors

#### Introduction

The ability of Eaton hydraulic components to provide the desired performance and life expectancy depends largely on the fluid used. The purpose of this section is to provide readers with the knowledge required to select the appropriate fluids for use in systems that employ Eaton hydraulic components.

One of the most important characteristics to consider when choosing a fluid to be used in a hydraulic system is viscosity. Viscosity choice is always a compromise; the fluid must be thin enough to flow easily but thick enough to seal and maintain a lubricating film between bearing and sealing surfaces. See chart below for viscosity requirements.

#### Viscosity and Temperature

Fluid temperature affects viscosity. In general, as the fluid warms it gets thinner and its viscosity decreases. The opposite is true when fluid cools. When choosing a fluid, it is important to consider the start-up and operating temperatures of the hydraulic system. Generally, the fluid is thick when the hydraulic system is started. With movement, the fluid warms to a point where a cooling system begins to operate. From then on, the fluid is maintained at the temperature for which the hydraulic system was designed. In actual applications this sequence varies; hydraulic systems are used in many environments from very cold to very hot. Cooling systems also vary from very elaborate to very simple, so ambient temperature may affect operating temperature. Equipment manufacturers who use Eaton hydraulic components in their products should anticipate temperature in their designs and make the appropriate fluid recommendations to their customers.

#### Cleanliness

Cleanliness of the fluid in a hydraulic system is extremely important. Eaton recommends that the fluid used in its hydraulic components be maintained at ISO Cleanliness Code 18/13 per SAE J1165. This code allows a maximum of 2500 particles per milliliter greater than 5  $\mu\text{m}$  and a maximum of 80 particles per milliliter greater than 15  $\mu\text{m}$ . Cleanliness requirements for specific products are given in the table below. OEM's and distributors who use Eaton hydraulic components in their products should provide for these requirements in their designs. A reputable filter supplier can supply filter information.

Char-Lynn Disc Valve Motors	Viscosity		ISO Cleanliness Requirements
	Minimum	Best Range	
	70 SUS 13 cSt	100-200 SUS 20-43 cSt	18/13

#### Additional Notes:

- Fluids too thick to flow in cold weather start-ups will cause pump cavitation and possible damage. **Motor cavitation is not a problem during cold start-ups (with one exception — two speed motors).**
- Minimum / Maximum operating temperatures are -29° C / 82° C [-20° F / 180° F].
- When choosing a hydraulic fluid, all the components in the system must be considered and the best viscosity range adjusted accordingly. For example, when a medium duty piston pump is combined with a Geroler motor the best viscosity range becomes

#### Fluid Maintenance

Maintaining correct fluid viscosity and cleanliness level is essential for all hydraulic systems. Since Eaton hydraulic components are used in a wide variety of applications it is impossible for Eaton to publish a fluid maintenance schedule that would cover every situation. Field testing and monitoring are the only ways to get accurate measurements of system cleanliness. OEM's and distributors who use Eaton hydraulic components should test and establish fluid maintenance schedules for their products. These maintenance schedules should be designed to meet the viscosity and cleanliness requirements laid out in this document.

#### Fluid Selection

Premium grade petroleum based hydraulic fluids will provide the best performance in Eaton hydraulic components. These fluids typically contain additives that are beneficial to hydraulic systems. **Eaton recommends fluids that contain anti-wear agents, rust inhibitors, anti-foaming agents, and oxidation inhibitors.** Premium grade petroleum based hydraulic fluids carry an ISO VG rating.

SAE grade crankcase oils may be used in systems that employ Eaton hydraulic components, but it should be noted that these oils may not contain all of the recommended additives. This means using crankcase oils may increase fluid maintenance requirements.

Hydraulic fluids that contain V.I. (viscosity index) improvers, sometimes called multi-viscosity oils, may be used in systems that employ Eaton hydraulic components. These V.I. improved fluids are known to "shear-down" with use. This means that their actual viscosity drops below the rated value. Fluid maintenance must be increased if V.I. improved fluids are used. Automotive automatic transmission fluids contain V.I. improvers.

Synthetic fluids may be used in Eaton hydraulic components. A reputable fluid supplier can provide information on synthetic fluids. Review applications that require the use of synthetic fluids with your Eaton representative.

100 - 150 SUS [20 - 32 cSt] and viscosity should never fall below 70 SUS [13 cSt].

- If the natural color of the fluid has become black it is possible that an overheating problem exists.
- If the fluid becomes milky a water contamination problem may exist.
- Take fluid level reading when the system is cold.
- Contact your Eaton representative if you have specific questions about the fluid requirements of Eaton hydraulic components.

## Motor Application Information — Vehicle Drive Calculations

### Step One — Calculate Motor Speed (RPM)

$$\text{RPM} = \frac{2.65 \times \text{KPH} \times G}{R_m} \quad \text{RPM} = \frac{168 \times \text{MPH} \times G}{R_1}$$

where KPH = vehicle speed (kilometers per hour)  
 where MPH = vehicle speed (miles per hour)  
 R<sub>m</sub> = rolling radius of tires (meter)  
 R<sub>1</sub> = rolling radius of tires (inch)  
 G = gear reduction ratio (if any) between motors and wheels. If no gear box or other gear reduction devices are used G = 1.

If vehicle speed is expressed in m/second, multiply by 3.6 to convert to KPH.

If vehicle speed is expressed in ft./second, divide by 1.47 to convert to MPH.

### Step Two — Determine Rolling Resistance

Rolling resistance (RR) is the force required to propel a vehicle over a particular surface. The values in Table 1 are typical of various surfaces per 1000 lb. of vehicle weight.

$$\text{RR} = \text{GVW} \times \rho \text{ (kg) (lb)}$$

where GVW = gross (loaded) vehicle weight lb/Kg  
 ρ = value from Table 1

**Table 1 - Rolling Resistance Coefficients for Rubber Tires on Various Surfaces**

Surface	ρ
Concrete, excellent	.010
Concrete, good	.015
Concrete, poor	.020
Asphalt, good	.012
Asphalt, fair	.017
Asphalt, poor	.022
Macadam, good	.015
Macadam, fair	.022
Macadam, poor	.037
Snow, 2 inch	.025
Snow, 4 inch	.037
Dirt, smooth	.025
Dirt, sandy	.040
Mud	.037 to .150
Sand, Gravel	.060 to .150
Sand, loose	.160 to .300

### Step Three — Tractive Effort to Ascend Grade

The largest grade a vehicle can ascend is called its "gradability." Grade is usually expressed as a percent rather than in degrees. A rise of one meter in ten meters or one foot rise in ten feet of travel is a 1/10 or 10 percent grade.

$$\text{GR} = \text{GVW} (\sin \theta + \rho \cos \theta)$$

**Table 2**

Comparison Grade (%)	Table Slope (Degrees)
1%	0°35'
2%	1°9'
5%	2°51'
6%	3°26'
8%	4°35'
10%	5°43'
12%	6°5'
15%	8°31'
20%	11°19'
25%	14°3'
32%	18°
60%	31°

### Step Four — Determine Acceleration Force (FA)

The force (FA) required to accelerate from stop to maximum speed (KPH) or (MPH) in time (t) seconds can be obtained from the following equation:

### Step Five — Determine Drawbar Pull

Drawbar Pull (DP) is total force available at the drawbar or "hitch" after the above forces have been subtracted from the total propelling force produced by the hydraulic motors. This value is established as either:

$$\text{FA} = \frac{\text{KPH} \times \text{GVW} \text{ (kg)}}{3.6 \text{ t}}$$

FA = Acceleration Force (Newton)  
 t = Time (Seconds)

$$\text{FA} = \frac{\text{MPH} \times \text{GVW} \text{ (lb)}}{22 \text{ t}}$$

FA = Acceleration Force (lb)  
 t = Time (Seconds)

1. A goal or objective of the designer.
2. A force required to pull a trailer (Repeat steps two through four above using trailer weight and add the three forces together to obtain DP).

**Step Six — Total Tractive Effort**

The tractive effort (TE) is the total force required to propel the vehicle and is the sum of the forces determined in Steps 2 through 5.

$$TE = RR + GR + FA + DP \text{ (Kg. or lb.)}$$

$\swarrow$  Drawbar pull desired  
 $\swarrow$  Force required to accelerate  
 $\swarrow$  Force required to climb a grade  
 $\swarrow$  Force required to overcome rolling resistance

Wind resistance forces can usually be neglected. However, it may be wise to add 10% to the above total to allow for starting resistances caused by friction in bearings and other mechanical components.

**Step Seven — Calculate Hydraulic Motor Torque (T)**

$$T = \frac{TE \times R_m}{N \times G \times E_g} \text{ (Nm / Motors)}$$

$$T = \frac{TE \times R_l}{N \times G \times E_g} \text{ (lb-in / Motors)}$$

where N = number of driving motors  
 Eg = gear box mechanical efficiency

**Step Eight—Wheel Slip**

If the torque required to slip the wheel (TS) is less than the torque calculated in Step 7, the performance objectives cannot be achieved.

$$TS = \frac{W \times f \times R_m}{G \times E_g} \text{ (Nm / Motor)}$$

$$TS = \frac{W \times f \times R_l}{G \times E_g} \text{ (lb-in / Motor)}$$

Where: f = coefficient of friction  
 W = loaded vehicle weight over drive wheel

**Coefficient of friction (f)**

Steel on steel	0.15 to 0.20
Rubber tire on dirt	0.5 to 0.7
Rubber tire on asphalt	0.8 to 1.0
Rubber tire on concrete	0.8 to 1.0
Rubber tire on grass	0.4

It may be desirable to allow the wheel to slip to prevent hydraulic system overheating when excessive loads are imposed should the vehicle stall. In this case TS should be just slightly larger than T.

**Step Nine — Motor Radial Load Carrying Capacity**

When a motor is used to drive a vehicle with the wheel mounted directly on the motor shaft or rotating hub, the Total Radial Load (RL) acting on the motor shaft is the vector summation of two forces acting at right angles to each other.

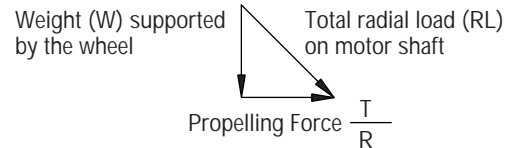

$$RL = \sqrt{W^2 + \left(\frac{T}{R}\right)^2}$$

Refer to radial load rating of each motor (see table of catalog contents page 10 for page listing of the Shaft Side Load Capacity for each motor series).

**Shaft Torque**

$$\frac{T}{2\pi} = \frac{q\Delta P}{62.8} \text{ Nm} = \frac{\text{PSI} \times \text{in}^3/\text{rev}}{6.28} = \text{lb-in}$$

**Shaft Speed**

$$\text{RPM} = \frac{\text{Flow}}{\text{Displacement}} = \frac{1000 \times \text{l/min}}{\text{cm}^3/\text{rev}} \text{ RPM} = \frac{231 \times \text{GPM}}{\text{in}^3/\text{rev}}$$

**Power (into motor)**

$$\text{Kw} = \frac{\text{bar} \times \text{l/min}}{600} \text{ HP} = \frac{\text{PSI} \times \text{GPM}}{1714}$$

**Power (out of motor)**

$$\text{Kw} = \frac{\text{Nm} \times \text{RPM}}{9549} \text{ HP} = \frac{\text{lb-in} \times \text{RPM}}{63,025}$$

where: Kw = Kilowatt  
 HP = Horsepower  
 LPM = Liters per Minute  
 GPM = Gallons per Minute  
 Nm = Newton Meters  
 lb-in = Pound inch  
 Bar = 10 Newtons per Square Centimeter  
 PSI = Pounds per Square Inch  
 q = Displacement



Eaton Corporation is a global manufacturer of highly engineered products that serve industrial, vehicle, construction, commercial, aerospace and semiconductor markets. Principal products include hydraulic products and fluid connectors, electrical power distribution and control equipment, truck drivetrain systems, engine components, ion implanters and a wide variety of controls. Headquartered in Cleveland, Ohio, the company has 63,000 employees and 195 manufacturing sites in 23 countries around the world. Eaton's sales for 1999 were \$8.4 billion.

Information contained in this catalog is accurate as of the publication date and is subject to change without notice. Performance values are typical values. Customers are responsible for selecting products for their applications using normal engineering methods.

### Eaton Hydraulics

14615 Lone Oak Road  
Eden Prairie, MN 55344  
Telephone: 952 937-7254  
Fax: 952 937-7130  
[www.eatonhydraulics.com](http://www.eatonhydraulics.com)

46 New Lane, Havant  
Hampshire PO9 2NB  
England  
Telephone: (44) 23 92-486-451  
Fax: (44) 23 92-487-110



**Quality System Certified**  
Products in this catalog are  
manufactured in an  
ISO-9001-certified site.